

**INSTRUCTION MANUAL
IDLE LINE MOTOR CONTROL UNIT
Model 202-2
Issue 4**

NOTE: This issue provided to cover Engineered changes to meet field comments for improvement.

1. AC cord - 10 feet length.
2. HUBBELL #5280 PLUG (AC) with knurled set screw to hold Plug in receptacle using 3rd wire Ground Pin.
3. Move of AC cord to end opposite the switch - clearing the operating area.
4. Change of Timing Resistor mounting terminals from wrapped wire solder connection to insertion of lead into hollow turret and soldering.

Electronic
IDLE LINE MOTOR CONTROL UNITS

CONTENTS	PAGE	
1.0 GENERAL	1	1.4 A NORMAL-BYPASS switch is provided to permit the ac to the controlled outlet (s) to be manually by-passed should operational procedures require it. The unit is shipped with the switch blocked in the NORMAL position.
2.0 FEATURES	1	
3.0 SPECIFICATIONS	1	
4.0 THEORY OF OPERATION	2	2.0 <u>FEATURES.</u> Two outlets are provided. Solid state construction, except for control relay. Six-foot cords provided, AC and DC Resistive input introduces no distortion. Neutral or Polar inputs.
5.0 INSTALLATION	2	
6.0 MAINTENANCE	4	
7.0 DRAWINGS	6	
1.0 <u>GENERAL</u>		3.0 <u>SPECIFICATIONS.</u> Input Impedance 100 ohms non-reactive Input Signals Accepted Neutral, 15-100 ma; Polar 7-50 ma (strap removed for prolar operation). Any standard telegraph or data speed up to 200 baud. Power Cutoff Timing Fixed at 1, 5, 10, 15 or 20 minutes + 15%, as ordered (20 minutes if not specified). Timing may be changed in field by resistor substitution. Current-Carrying Capacity at CONTROLLED Outlet (S) 20 amperes maximum, 115 VAC (combined total if both outlets controlled) Power Required 115 VAC (+10% 50-60 cps), 5 Watts Mounting 2-1/2 x 3-5/8 x 6-5/8 inches. Weight 3 pounds Restart Time 15 MS after receipt of M-S transition.
1.1 The 202 series Idle Line Motor Control Units are electronic versions of a device designed to control the 115 VAC supply to a teletypewriter motor (or other equipment). A timed interval is started at any time the signal input to the teleprinter becomes either idle or spacing (open). If no transmission is received prior to the end of this interval, the Motor Control Units relay disconnects the ac supply from the outlet connected to the teleprinter motor. Any mark-to-space transition received thereafter will cause the Unit to restore the ac power to the teleprinter almost instantly. It should be noted that if the Motor Control Unit has disconnected power to the teleprinter, the initial one or two characters received may be garbled because the teleprinter motor requires approximately 100 milliseconds before it comes up to full speed after power is reconnected.		
1.2 The timed idle line or open interval before power cutoff occurs is fixed at the factory. The number of minutes is stenciled on the outside of the case. This fixed interval may be changed by substitution of resistors as described in the Installation Section of this manual.		
1.3 Two power outlets are provided. Unless ordered otherwise, the Model 202-2 is shipped with both outlets wired to be under control of the cut-off relay. However, through a simple strapping change, described in the Installation Section of this manual, one of the two outlets may be made uncontrolled, to serve as a conveniency outlet for connection of equipment not requiring control (e.g. Western Electric 130 Type Subsets).		

4.0 THEORY OF OPERATION (Refer to Schematic Drawing)

4.1 Power is supplied to the timing circuits from a full-wave rectifier negative supply and a half-wave positive supply. Transformer T1 provides isolation between circuit ground and the telegraph loop. Fuse F1 protects the transformer from overloads. (When fuse F1 is removed and power is lost to the timing circuits, or when the BYPASS switch is operated, the teleprinter motor will operate continuously.)

4.1.2 Inductive kick-back from the load (s) connected to the controlled outlet is absorbed in a thyrector CR 16 to protect the unit relay K1 from excessively high induced voltages.

4.2 Timing

4.2.1 The timing circuit consists of a unijunction oscillator for the time base, three stages of binary counters, an amplifier to drive the power relay, and another two-stage amplifier to increase the voltage developed across the 100 ohm telegraph loop resistor R36.

4.3 Input Circuit

4.3.1 For neutral operation, a strap is connected between terminals 4 and 5. The 60 ma. marking loop connected to the input with the polarity shown will cause the top of resistor R36 to be -6 volts as referenced to circuit ground. This negative voltage will overcome the positive voltage supplied thru the strap (4, 5) at the base of Q10, causing Q10 to conduct. When Q10 conducts it causes Q9 to go non-conducting. When the neutral loop drops below approximately 13 ma., the positive voltage via the strap overcomes the negative voltage, causing Q10 to go non-conducting and Q9 to go conducting very quickly.

4.3.2 Capacitor C14 was discharged while Q9 was non-conducting and when Q9 goes conducting a momentary ground is applied to the anodes of CR5, CR9, and CR13. This ground is applied long enough to reset the counters.

4.3.3 Polar operation is similar to neutral operation except that the strap between terminals 4 and 5 must be removed. The negative, then positive, voltages developed across resistor R36 cause transistor Q10 to go conducting, then non-conducting.

4.4 Relay Amplifier

4.4.1 When the three counters are reset, the junction

of R25 and R26 is grounded through diodes CR6, CR11, and CR12. This ground cuts off Q8, de-energizing K1 which closes the contacts and applies ac power to the teleprinter motor.

4.5 Unijunction Oscillator

4.5.1 The ground on the junction of R25 and R26 also provides a charge path for C3 through resistors R1 and R2. When C3 charges to a certain potential, the emitter of unijunction Q1 fires and a pulse is sent to the first stage of the counters. After seven pulses from the oscillator, transistors Q3, Q5 and Q7 of the binary counters are non-conducting. This removes the ground from the junction of R25 and R26, stops the oscillator, and makes Q8 conduct which in turn operates relay K1 and stops the teleprinter motor.

4.5.2 Any mark-to-space transistion which occurs before the seventh count will reset the counters back to zero although the oscillator runs continuously.

5.0 INSTALLATION

5.1 The Motor Control Unit may be mounted in any position, either loose, or attached to the wall, floor, side of a teleprinter, or other suitable surface. Mounting bolts and self-tapping metal screws are provided with each Unit to facilitate installation using the three holes thru its rear panel. The holes on the left are on 2-1/4 inch centers to permit 19 inch relay rack installation.

CAUTION: WHEN POWER IS CONNECTED TO MOTOR CONTROL UNIT DANGEROUS AC VOLTAGE IS EXPOSED ON TERMINALS OF RECEPTACLE, SWITCH, RELAY, AND ELSEWHERE.

5.2 With ac power not connected to Motor Control Unit, remove four binding head screws, two on each side of Unit, and lift-off the cover.

5.3 The Model 202-2 is normally wired with both of its receptacles under the control of its cutoff relay. It is possible, however, to convert the outlet not designated as CONTROLLED so that it is no longer under the control of the relay and thereby have it serve as a normal, conveniency outlet. This conversion is performed by removing a lead from the ac receptacle and reconnecting it to the BYPASS switch. It will be noted that on one terminal of the ac receptacle there are two leads (both having red jacketed terminals). The lead to be removed from the receptacle is the top one of these two. The terminal on the switch to which it is to be connected already has one lead attached with a red

terminal. (The red terminal which is transferred always makes contact with another red terminal.) The drawing at the rear of this manual may assist in making this wiring change.

5.4 The Unit is shipped with a strap installed between terminals 4 and 5 of printed circuit BD No. 2. This strap must be removed if Motor Control Unit is to be used for polar operation, and reinstalled if Unit is changed later to a neutral circuit. Care should be used to apply minimum heat in soldering to terminals.

5.5 The Motor Control Unit is to be mounted in a convenient location, on or near the teleprinter or other device to be controlled, where there is convenient access from the Motor Control Unit to the data circuit input, 115 VAC outlet, and to the teleprinter power cord. If the mounting location is not readily accessible, it may be desirable to proceed with installation connections and operational tests on the Unit before fastening it to its final mounting location.

5.6 It will be necessary to open the input circuit to the teleprinter and to make tests to check out the installation. It is recommended, therefore, that the loop be removed from service and connected to a dummy circuit at the central office until the installation is complete.

5.7 Referring to the sketch below, insert the two-conductor cord spade terminals in series with the dc loop. The red-banded terminal of the cord is positive, and the other terminal is negative. Any convenient connecting place may be used, such as a loop switchboard or teleprinter where screw terminals are available.

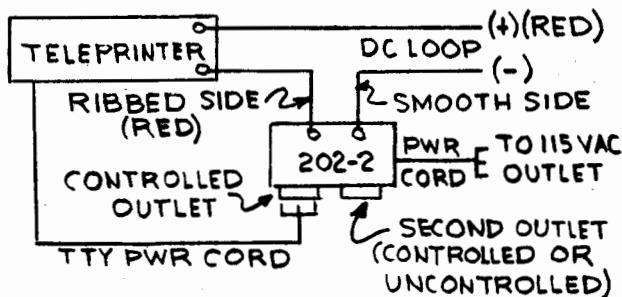

5.8 Plug the teleprinter power cord into the Motor control Unit outlet designated as CONTROLLED. A 6/32 screw is provided above the two outlets for mounting a cable clamp if desired. (The Phillips head screw should not be used for this purpose.)

5.9 The Motor Control Unit uses a three-conductor power cord which is to be connected to 115 VAC and provides three-conductor power outlets.

If its power cord is plugged into a grounded outlet, and the teleprinter cord has a three-conductor plug, the teleprinter chassis and motor and Motor Control Unit, will all be grounded. However, if a "cheater" plug is used, it is recommended that ground be connected separately.

Making Operational Checks

CAUTION: WHEN POWER IS CONNECTED, BEWARE OF TOUCHING ANY TERMINALS OTHER THAN THOSE SPECIFIED. DANGEROUS AC VOLTAGE IS EXPOSED.

- 5.10 Make sure that the BYPASS switch is in NORMAL position.
- 5.11 Plug Motor Control Unit power cord into 115 VAC outlet.
- 5.12 With input loop idle, apply a temporary strap across terminals 1 and 3 of BD No. 1, shorting out resistors R1 and R2.
- 5.13 Transmit a few characters from the teleprinter keyboard (or otherwise open and close the circuit a few times) to reset the Motor Control Unit's timing circuit. Note that approximately one minute later the relay operates causing the teleprinter motor to stop. If Unit fails to time-out, refer to Maintenance Section for further tests.
- 5.14 Introduce a single character or momentary mark-to-space transition which should then release the relay and restore power to the CONTROLLED outlet (s). If Unit fails to reset, refer to Maintenance Section for further tests.
- 5.15 Remove strap from terminals 1 and 3 of BD No. 1.
- 5.16 The tests performed in Steps 11 thru 13 with the special strap were arranged to speed up the check of the Motor Control Unit's timing circuit. If the installer prefers, he may repeat Step 12 without the strap, timing the full period from the last mark-to-space transition until the Unit times out, which time interval should correspond to that stenciled on the cover within $\pm 15\%$. However, the speeded-up tests should be an adequate check of the Unit. (Note: The timing resistor values for R1 and R2 shown on the schematic are provided only as a guide $\pm 50\%$. They are adjusted as an R-C circuit for the time required $\pm 15\%$.)
- 5.17 Unless necessary to make further tests, or to change time-interval timing as described below, unplug power cord of Unit and replace its

cover. If not yet completed, finish mounting and final installation of the Unit. Reconnect power to Unit, return loop to service, and check loop current.

Changing Time Interval from Factory-Setting

5.18 In some applications, it may be necessary to change the idle/open time interval for power cutoff to some period different from that at which the factory setting was made. Values for resistor R1 and approximate values for resistor R2 are given on the Schematic Drawing for various time intervals. The procedure for making the change is as follows:

CAUTION: WHEN POWER IS CONNECTED, BEWARE OF TOUCHING ANY TERMINALS OTHER THAN THOSE SPECIFIED. DANGEROUS AC VOLTAGE IS EXPOSED.

5.19 Referring to drawing at the end of this manual for location, replace R1 with a half-watt, 10% resistor of the guide value for period desired. This resistor is located between terminals 2 and 3 of BD No. 1. Do not use excessive heat in soldering to the terminals.

5.20 Remove R2 from terminals 1 and 2 of BD No. 1 and clip in its place a half-watt resistor of the approximate value of R2 shown on the drawing for the period desired.

5.21 Connect a dummy input loop to supply marking current as previously described. Momentarily open loop to reset timing circuit. Using a watch, time the period until the teleprinter goes off. Increase resistance to increase timing, reduce resistance to reduce timing. When desired timing is achieved, install half-watt resistor of determined value between terminals 1 and 2 of BD No. 1 and solder. Do not apply too much heat.

5.22 After completing re-timing of Unit, redesignate timing on cover.

5.23 Retiming services are available from the manufacturer at a nominal service charge.

6.0 MAINTENANCE

6.1 As a solid-state device, other than its control relay, the 202 series Motor Control Unit is designed for minimum maintenance. If an oscilloscope or vacuum-tube voltmeter is available, many simple checks may be made as described below.

CAUTION: IF IT BECOMES NECESSARY TO

CHANGE COMPONENTS BE CAREFUL NOT TO OVERHEAT PRINTED CIRCUIT BOARDS.

IN THE TESTS DESCRIBED BELOW, VOLTAGE CHECKS ARE SPECIFIED AT VARIOUS TEST POINTS. THESE MEASUREMENTS ARE WITH REFERENCE TO CIRCUIT GROUND WHICH APPEARS ON THE POSITIVE INPUT LOOP TERMINAL. DO NOT USE CHASSIS GROUND AS THIS WILL CAUSE DAMAGE TO THE UNIT.

6.2 If Motor Control Units Fails to Time-Out and Cut Off Power:

6.2.1 Examine relay K1 contacts for evidence of sticking or welding.

6.2.2 If relay looks OK, check for positive and negative 25 VDC at indicated TP points on BD No. 2. If it appears power supply is not functioning, check fuse F1. If power supply is in trouble, but fuse is OK, check diodes CR1, CR2, and CR3. If fuse is bad and replacement fuse blows, check capacitors C1 and C2.

6.2.3 If power supply is OK, and with no strap between terminals 1 and 3, check point A which should go from -20 VDC to ground approximately every three minutes (typical timing for twenty minute Unit). If test point A does not go to ground, check transistors Q2 and Q3 and unijunction Q1.

6.2.4 If test point A is OK, check for momentary ground at test point B approximately every six minutes (typical for twenty minute Unit). If test point B does not go to ground, check transistors Q4 and Q5.

6.2.5 If test point B is OK, check for momentary ground at test point C approximately every twelve minutes (typical for twenty minute Unit). If test point C does not go to ground, check transistors Q6 and Q7.

6.2.6 If test point C is OK, check voltage on test point E, which should be about -20VDC when test points A, B, and C are also at about -20 VDC. (All associated transistors non-conducting.) If test point E voltage is correct, check transistor Q8 which should be ground (conducting).

6.2.7 If transistor Q8 is OK, examine relay coil.

6.3 If Motor Control Unit Fails to Reset:

6.3.1 With input loop idle, marking, and strap 4 and 5 in or out as determined by neutral or polar operation respectively, check for negative

battery (approximately -22VDC) on test point D. If test point D measures some other voltage, check transistors Q9 and Q10.

6.3.2 With input loop spacing, test point D should be at ground. If test point D is above ground, check transistors Q9 and Q10.

6.3.3 If test point D is OK, check diodes CR5, CR9 and CR13.

6.3.4 Factory service and parts are available on an expedited basis and at nominal cost.

6.4 Current Limiting Factors

6.4.1 The D. C. Telegraph Loop input resistor R36, 100 ohms, is rated at 3 watts for normal loop operation from the central office where heat coils are provided.

6.4.2 The heat coils will operate should current in excess of about 150 milliamperes is caused due to trouble or maladjustment.

6.4.3 When the unit is used in a circuit where the current can exceed 175 ma due to trouble without operating a fuse, consideration should be given to the circuit arrangement in which the unit is to be wired.

6.4.4 For example, in a 20 ma station using rectifiers and equipment where the circuit might be fused at 3/8 amperes but trouble current is limited to 400 ma, the unit should be wired so that the trouble causing the 400 ma current would cause no current to flow through the unit.

6.4.5 A Model 5406-1 may be wired across the DC loop input cord terminals of the unit to by-pass the excess current until the fuse does operate, thus protecting the input resistor from excessive current.

7.0 DRAWINGS FURNISHED

Schematic-D200007

Printed Circuit Board No. 1 - C500053

Printed Circuit Board No. 2 - C500054

Outline Drawing - C400002

Final Assembly - D100008

MODEL 202 (TOP VIEW WITH COVER REMOVED)

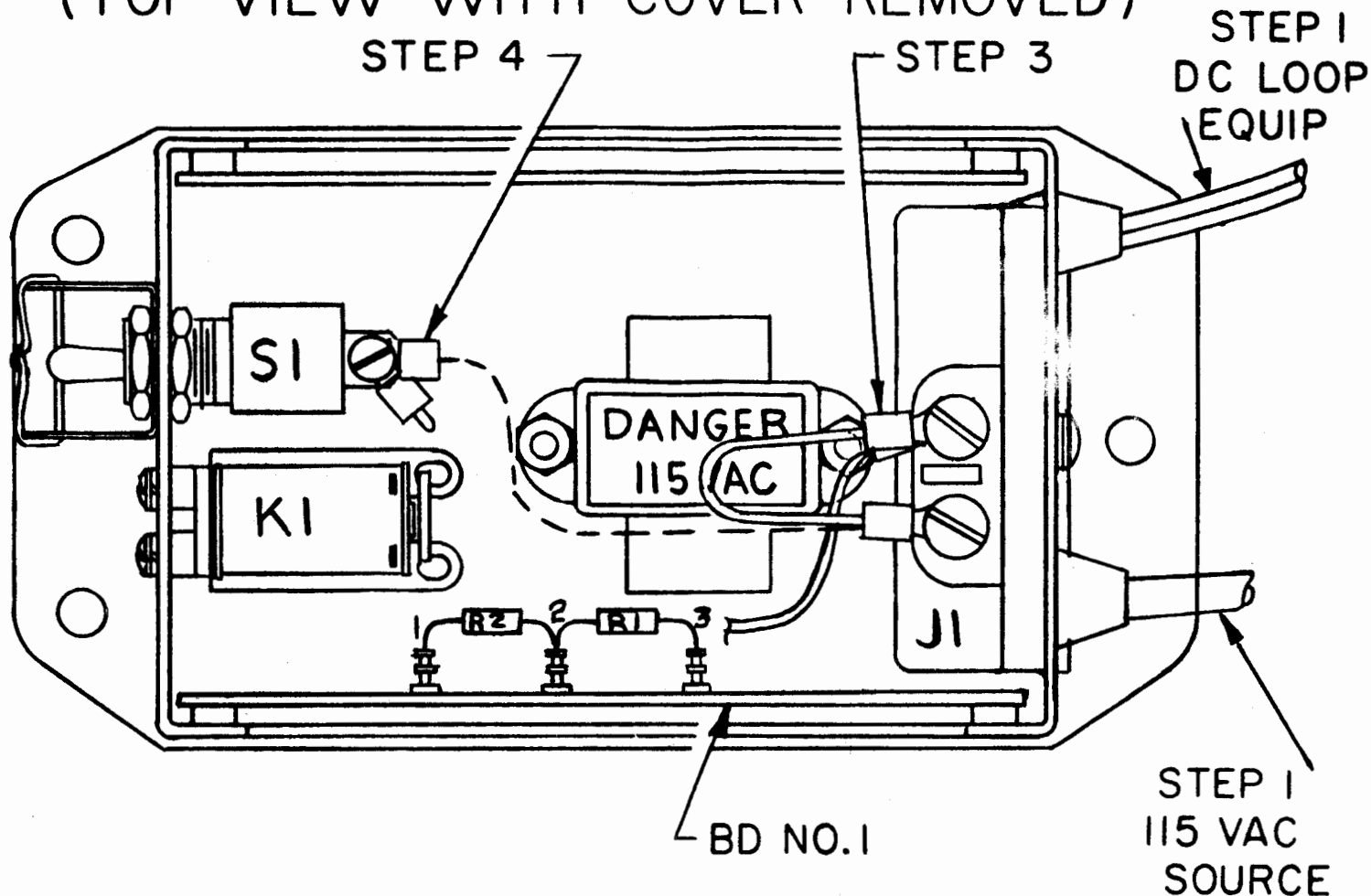

STEP PROCEDURE FOR FIELD CONVERSION OF MODEL 202-2 FROM TWO CONTROLLED OUTLETS TO ONE CONTROLLED AND ONE UNCONTROLLED OUTLET.

1. Remove ac power plug from external 115 VAC source. Remove dc loop connections from external equipment. (Note the terminations so equipment will be reconnected properly.)
2. Remove unit from mounting position if necessary. Remove cover by means of 4 screws (2 on each side).

CAUTION: BE CERTAIN POWER IS DISCONNECTED AS HAZARDOUS VOLTAGES ARE EXPOSED WHEN COVER IS REMOVED AND AC POWER PLUG IS CONNECTED TO EXTERNAL SOURCE.

3. Referring to the sketch above, remove the indicated red insulated lug of wire loop, approximately 3 in. long from J1. Another termination will be found on this screw. Retighten screw to maintain remaining termination.
4. Secure the terminal removed in Step 3 to the indicated top screw terminal of S1 (under existing lug). (Note: Some units contain a different type of switch than shown but terminations are still made to top lug.) The jumper will now connect as shown by the dotted line.
5. Replace cover. Unit may now be returned to service.

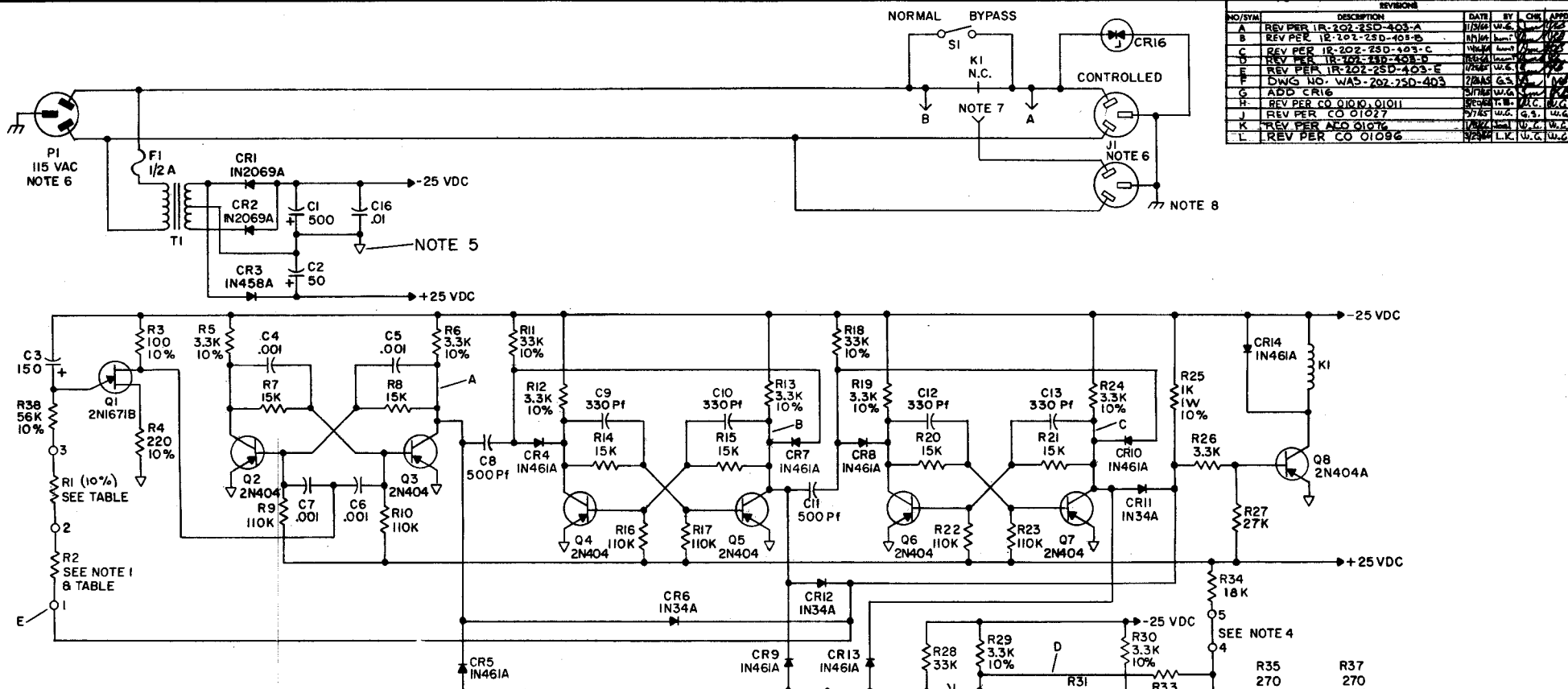

REVISIONS					
NO/SYM	DESCRIPTION	DATE	BY	CHK	APPD
A	REV PER IR-202-25D-403-A	11/26/64	W.C.G.		
B	REV PER IR-202-25D-403-B	11/26/64	W.C.G.		
C	REV PER IR-202-25D-403-C	11/26/64	W.C.G.		
D	REV PER IR-202-25D-403-D	11/26/64	W.C.G.		
E	REV PER IR-202-25D-403-E	11/26/64	W.C.G.		
F	DWG NO. WA5-267-75D-403	2/24/65	G.S.		
G	ADD CR16	5/18/65	W.C.G.		
H	REV PER CO 01010, 01011	8/26/65	W.C.G.		
J	REV PER CO 01027	9/25/65	W.C.G.		
K	REV PER CO 01076	11/22/65	W.C.G.		
L	REV PER CO 01096	9/24/66	L.K.	W.C.G.	

- NOTES:
- EXACT VALUE DETERMINED BY PRODUCTION AND CAN VARY AS MUCH AS $\pm 50\%$ OF THE NOMINAL VALUE.
 - ALL RESISTANCE IN OHMS, 1/2 WATT, $\pm 5\%$ UNLESS OTHERWISE NOTED.
 - ALL CAPACITANCE IN μf UNLESS OTHERWISE NOTED.
 - REMOVE THIS STRAP FOR POLAR OPERATION.
 - POINTS MARKED A, B, C, D & E ARE TEST POINTS WITH REFERENCE TO CIRCUIT GROUND ONLY.
 - "J1" & "P1" ARE OF THE POLARIZED PARALLELED TYPE. "J1" IS AS SHOWN IN DETAIL "A". "P1" WILL MATE WITH THIS RECEPTACLE.
 - STRAP TO POINT "A" TO CONNECT BOTH OUTLETS CONTROLLED. POSITION STRAP TO POINT "B" TO CONNECT ONE OUTLET CONTROLLED AND ONE UNCONTROLLED.
 - THIRD WIRE GROUND TIED TO CHASSIS.

TIME	R1 C3=100MFD	R1 C3=150MFD	R2 NOMINAL
1 MINUTE	NONE STRAP TERM 2 & 3	NONE STRAP TERM 2 & 3	47K
5 MINUTES	220K	150K	220K
10 MINUTES	470K	330K	390K
15 MINUTES	1 MEG	560K	390K
20 MINUTES	1.2 MEG	820K	620K
3 MINUTES	75K	75K	

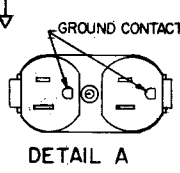

QTY	MANUFACTURER	PART OR	ITEM	NOMENCLATURE OR	NOTES & REF
REQD	OR SUPPLIER	IDENT NUMBER		DESCRIPTION	DESIGNATIONS
-1					
LIST OF MATERIAL					
UNLESS OTHERWISE SPECIFIED DIMENSIONS ARE IN INCHES		GLEADALL, W. 10/17/64		PULSE COMMUNICATIONS, INC.	
TOLERANCES:		DATE 10/17/64		ALEXANDRIA, VA.	
2 PLACE DECIMALS \pm		DATE 10/17/64		SCHEMATIC (IDLE LINE MOTOR CONTROL) (MODEL 202-2)	
3 PLACE DECIMALS \pm		DATE 10/17/64			
ANGLES \pm		DATE 10/17/64			
DO NOT SCALE DRAWING					
MATERIAL:		COORD. ENGR. NO. 22818		DRAWING NUMBER D200007	
FINISH:		SCALE:		SHEET	

REVISIONS					
NO/SYM	DESCRIPTION	DATE	BY	CHK	APPD
A	REV. ITEM 21, ADDED ITEM 22	9/8/64	facom		W.B.
B	REV PER IR 202-1AD-309-B	3/11/64	W.G.		W.B.
C	REV PER IR 202-1AD-309-C	9/11/64	W.G.		W.B.
D	REV PER IR 202-1AD-309-D	28 DEC 64	W.G.		W.B.
E	REV PER IR 202-1AD-309-E	1/27/65	W.G.		W.B.
F	DWG NO. WAS 202-1AD-309	2/27/65	G.S.	W.G.	W.G.
G	REV PER CO 01010, CO 01011	5/19/65	T.B.	W.C.	W.G.
H	REV PER CO 01027	9/7/65	W.G.	G.S.	W.G.
I	REV PER CO 01042	1/19/65	W.C.	W.C.	W.G.
J	REV PER ACO 01076	1/5/66	W.C.	W.C.	W.G.
K	REV PER CO 01096	3/29/66	L.K.	W.G.	W.C.
M	REV PER CO 01116	1/7/66	W.C.	W.C.	W.G.
N	REV PER ACO 01187	3-2-67	FDL	W.G.	W.G.

- NOTES:
1. TIME OF R1 CAN BE OBTAINED FROM PURCHASE ORDER.
 2. VALUE OF R2 IS DETERMINED BY PRODUCTION PROCESS
 3. EITHER 5A-1N461A OR B500034 MAY BE USED
 4. EITHER 5A-1N34A OR B500144 MAY BE USED.
 5. EITHER 21A-2N404 OR 21A-6A3068 MAY BE USED.

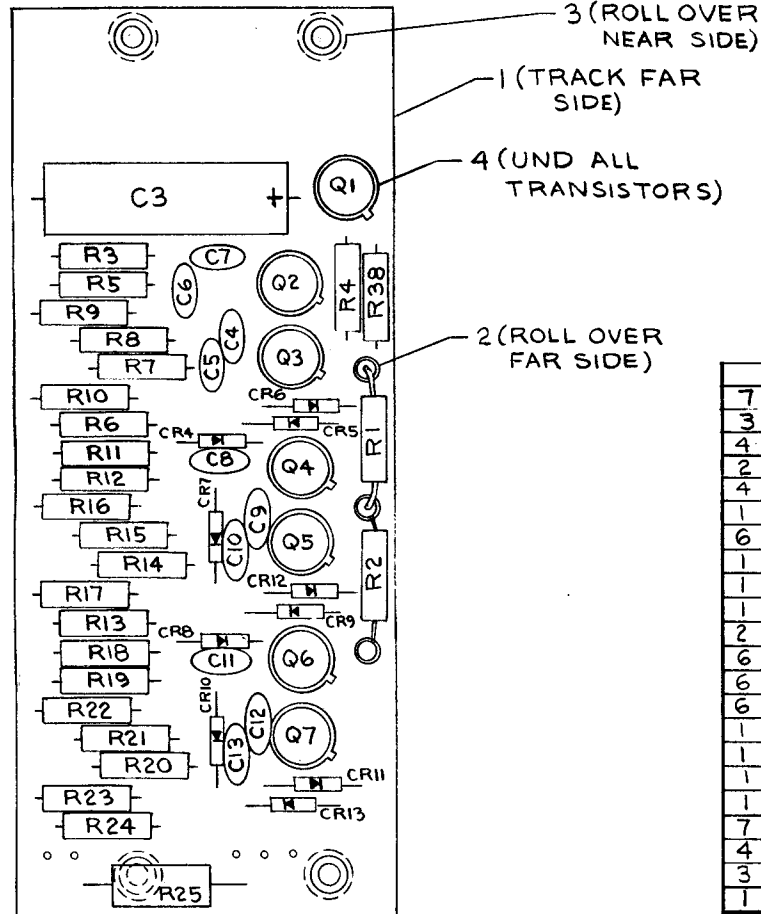

TABLE 2

TIME	R1 VALUE
15 MIN	560K 1/2W 10%
20 MIN	820K 1/2W 10%
10 MIN	330K 1/2W 10%
5 MIN	150K 1/2W 10%
1 MIN	STRAP TERM. 2 & 3 (NO RESISTOR)
3 MIN	75K 1/2W 10%

TABLE 1

ITEM	REF DESIGNATION
9	R5, R6, R12, R13, R19, R24
10	R7, R8, R14, R15, R20, R21
11	R9, R10, R16, R17, R22, R23
22	CR4, CR5, CR7, CR8, CR9, CR10, CR13

7	SEE NOTE 3	22	DIODE	SEE TABLE I
3	SEE NOTE 4	21	DIODE	CR6, CR11, CR12
4	3A-331P-20X-102	20	CAPACITOR (330PF, 1000VDC)	C9, C10, C12, C13
2	3A-501P-20X-102	19	CAPACITOR (500PF, 1000VDC)	C8, C11
4	3A-102P-20X-102	18	CAPACITOR (.001 MFD, 1000VDC)	C4 THRU C7
1	3B-150M-20X-15X	17	CAPACITOR (150MFD, 15 VDC)	C3
6	SEE NOTE 5	16	TRANSISTOR	Q2 THRU Q7
1	21A-2N1671-B	15	TRANSISTOR	Q1
1	17A-5602-X5-10	14	RESISTOR (56K, 1/2W, 10%)	R38
1	17A-1001-1X-10	13	(1K, 1W, 10%)	R25
2	17A-3302-X5-10	12	(33K, 1/2W, 10%)	R11, R18
6	17A-1103-X5-5X	11	(110K, 1/2W, 5%)	SEE TABLE I
6	17A-1502-X5-5X	10	(15K, 1/2W, 5%)	SEE TABLE I
6	17A-3301-X5-10	9	(3.3K, 1/2W, 10%)	SEE TABLE I
1	17A-220X-X5-10	8	(220Ω, 1/2W, 10%)	R4
1	17A-100X-X5-10	7	(100Ω, 1/2W, 10%)	R3
1	SEE NOTE 2	6		R2
1	NOTE 1 & TABLE 2	5	RESISTOR	R1
7	9H-0001	4	TRANSISTOR PAD	
4	9J-0001	3	SPACER, ROLLOVER	
3	4H-0025	2	TERMINAL, ROLLOVER	
1	C500052	1	BOARD, PRINTED CIRCUIT	

QTY	MANUFACTURER OR SUPPLIER	PART OR IDENT NUMBER	ITEM	NOMENCLATURE OR DESCRIPTION	NOTES & REF DESIGNATIONS
-1					
LIST OF MATERIAL					
UNLESS OTHERWISE SPECIFIED DIMENSIONS ARE IN INCHES		GLEADALL, W	14 JUL 64	PULSE COMMUNICATIONS, INC. ALEXANDRIA, VA. BOARD #1 P.C. ASSY	
TOLERANCES:		DRAWN	DATE		
2 PLACE DECIMALS ±		DALTON J	3 AUG 64		
3 PLACE DECIMALS ±		CHECKED	DATE		
ANGLES ±		PROJ ENGR	DATE		
DO NOT SCALE DRAWING		PROJ ENGR	DATE		
MATERIAL:		CAUTION: UNLESS THIS DRAWING BEARS THE NAME OF THE "PULSE ENGINE" TRADE DESIGN IT IS PRELIMINARY AND UNDER NO CIRCUMSTANCES IS IT TO BE USED FOR MANUFACTURING PURPOSES.		CODE IDENT NO. SIZE DRAWING NUMBER	
FINISH:		THIS DRAWING IS FURNISHED FOR ENGINEERING INFORMATION AND REFERENCE ONLY. THE PURCHASER OF THIS DRAWING DOES NOT CONVEY ANY REPRODUCTION OR MANUFACTURING RIGHTS.		22818 C C500053	
		SCALE: 2/1		SHEET	

REVISIONS					
NO/SYM	DESCRIPTION	DATE	BY	CHK	APPD
A	ADDED NOTE 3 FADD SPR. PT. NO.	2/13/64	W.S.		W.S.
B	REV PER IR. 202-1AD-310-B	12-22-64	W.S.		W.S.
C	DWG NO. WAS 202-1AD-310	2/17/65	G.S.		W.G.
D	REV PER ACO 01006	5/5/65	JB		W.G.
E	REV PER CO 01042	4/9/65	W.S.		W.G.
F	REV PER CO 01096	3/29/66	L.K.		W.G.
G	ADDED-2	3/27/66	W.S.		W.G.
H	REV PER CO 01116	1/7/66	W.S.		W.G.
I	REV PER CO 01137	8/12/67	L.C.	G.S.	G.S.

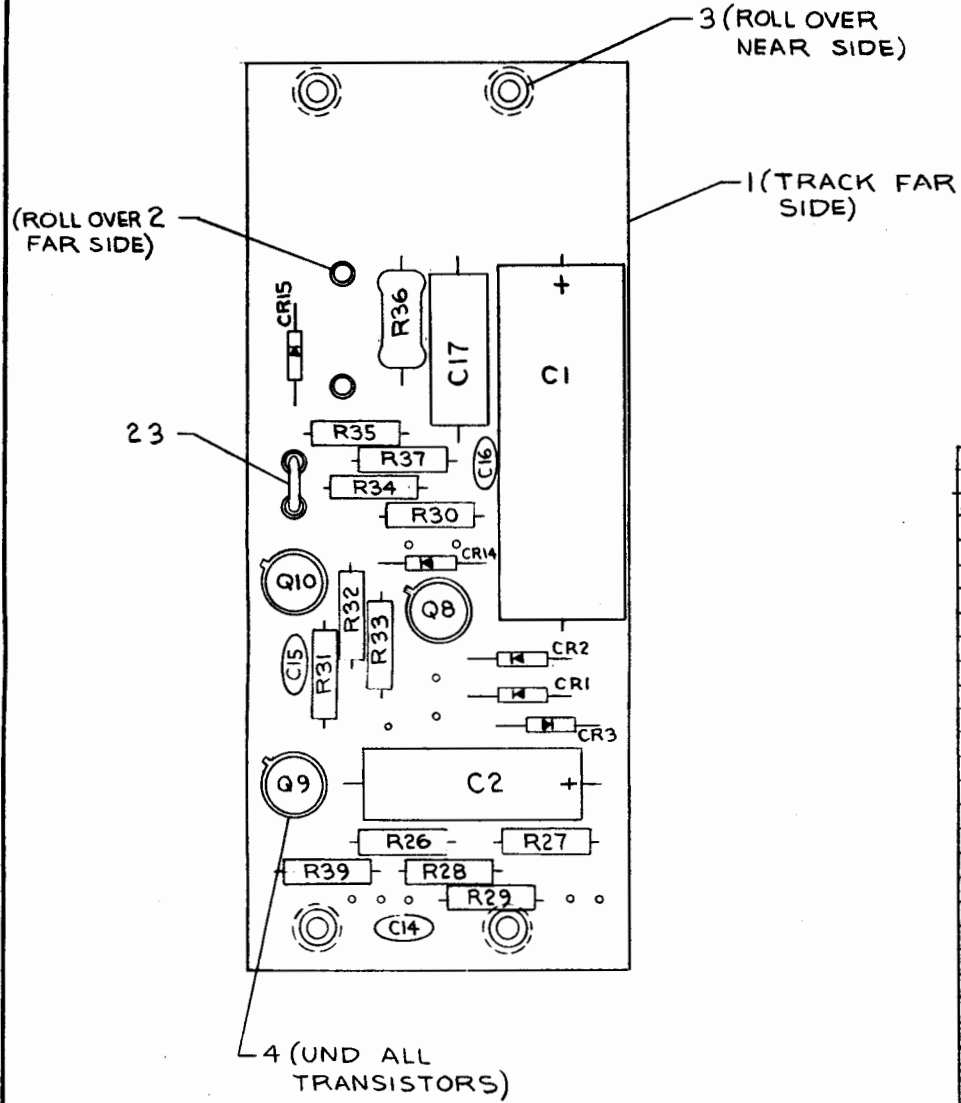

NOTES:
 1. EITHER 5A-1N458A OR B500035 MAY BE USED.
 2. EITHER 5A-1N461A OR B500034 MAY BE USED.
 3. EITHER 5A-1N 2069A OR B500040 MAY BE USED.
 4. EITHER 21A-2N404 OR 21A 6A306B MAY BE USED.

1	0		17F-300X-3X-5X	25	RESISTOR (300Ω, 3W, 5%)	R36
1	1		17A-3301-X5-5X	24	RESISTOR, CARBON	R26
	.75" IN	.75" IN	23B-22	23	WIRE, ELECTRICAL	BARE
1	1		3B-5X0M-75X-25X	22	CAPACITOR (5MFD, 25V)	C17
3	3		3A-103P-20X-50X	21	CAPACITOR (.01MFD, 50V)	C14, C15, C16
1	1		3B-50XM-100-25X	20	CAPACITOR (50MFD, 25V)	C2
1	1		3B-501M-150-25X	19	CAPACITOR (500MFD, 25V)	C1
2	2		SEE NOTE 2	18	DIODE	CR14, CR15
1	1		SEE NOTE 1	17	DIODE	CR3
2	2		SEE NOTE 3	16	DIODE	CR1, CR2
2	2		SEE NOTE 4	15	TRANSISTOR	Q9, Q10
1	1		21A-2N404 A	14	TRANSISTOR	Q8
0	1		17F-100X-3X-5X	13	RESISTOR (100Ω, 3W, 5%)	R36
2	2		17A-270X-X5-5X	12	RESISTOR (270Ω, 1/2W, 5%)	R35, R37
1	1		17A-180Z-X5-5X	11	(18K, 1/2W, 5%)	R34
1	1		17A-1103-X5-5X	10	(110K, 1/2W, 5%)	R32
1	1		17A-150Z-X5-5X	9	(15K, 1/2W, 5%)	R31
2	2		17A-3301-X5-10	8	(33K, 1/2W, 10%)	R29, R30
2	2		17A-3302-X5-5X	7	(33K, 1/2W, 5%)	R28, R33
1	1		17A-1203-X5-5X	6	(120K, 1/2W, 5%)	R39
1	1		17A-270Z-X5-5X	5	RESISTOR (27K, 1/2W, 5%)	R27
3	3		9H-0001	4	TRANSISTOR PAD	
4	4		9J-0001	3	SPACER, ROLLOVER	
4	4		4H-0025	2	TERMINAL, ROLLOVER	
1	1		C500051	1	BOARD, PRINTED CIRCUIT	

QTY REQD	QTY REQD	MANUFACTURER OR SUPPLIER	PART OR IDENT NUMBER	ITEM	NOMENCLATURE OR DESCRIPTION	NOTES & REF DESIGNATIONS
-2	-1					
LIST OF MATERIAL						
UNLESS OTHERWISE SPECIFIED DIMENSIONS ARE IN INCHES		GLEADALL, W	14 JUL '64	PULSE COMMUNICATIONS, INC. ALEXANDRIA, VA.		
TOLERANCES:		DRAWN	DATE	BOARD #2 P.C. ASSY		
2 PLACE DECIMALS ±		CHECKED	DATE			
3 PLACE DECIMALS ±		PROJ ENGR	DATE			
ANGLES ±		PROD ENGR	DATE			
DO NOT SCALE DRAWING						
MATERIAL:		CAPTION: UNLESS THIS DRAWING BEARS THE NAME OF THE "PULSE COMMUNICATIONS, INC." OR "PULSE COMMUNICATIONS, INC. ENGINEERING" IT IS PRELIMINARY AND UNDER NO CIRCUMSTANCES IS IT TO BE USED FOR MANUFACTURING PURPOSES.		CODE IDENT NO.	SIZE	DRAWING NUMBER
FINISH:		THIS DRAWING IS FURNISHED FOR ENGINEERING INFORMATION AND REFERENCE ONLY. THE PURCHASING OF THIS DRAWING DOES NOT CONVEY ANY REPRODUCTION OR MANUFACTURING RIGHTS.		22818	C	C500054
				SCALE: 2/1	SHEET	

REVISIONS					
NO/SYM	DESCRIPTION	DATE	BY	CHK	APPD
A	DWG NO. WAS 202-2FD-301	7/27/65	G.S.	W.G.	W.G.
B	REV PER CO 0117	7/13/66	W.G.	Joel	W.G.

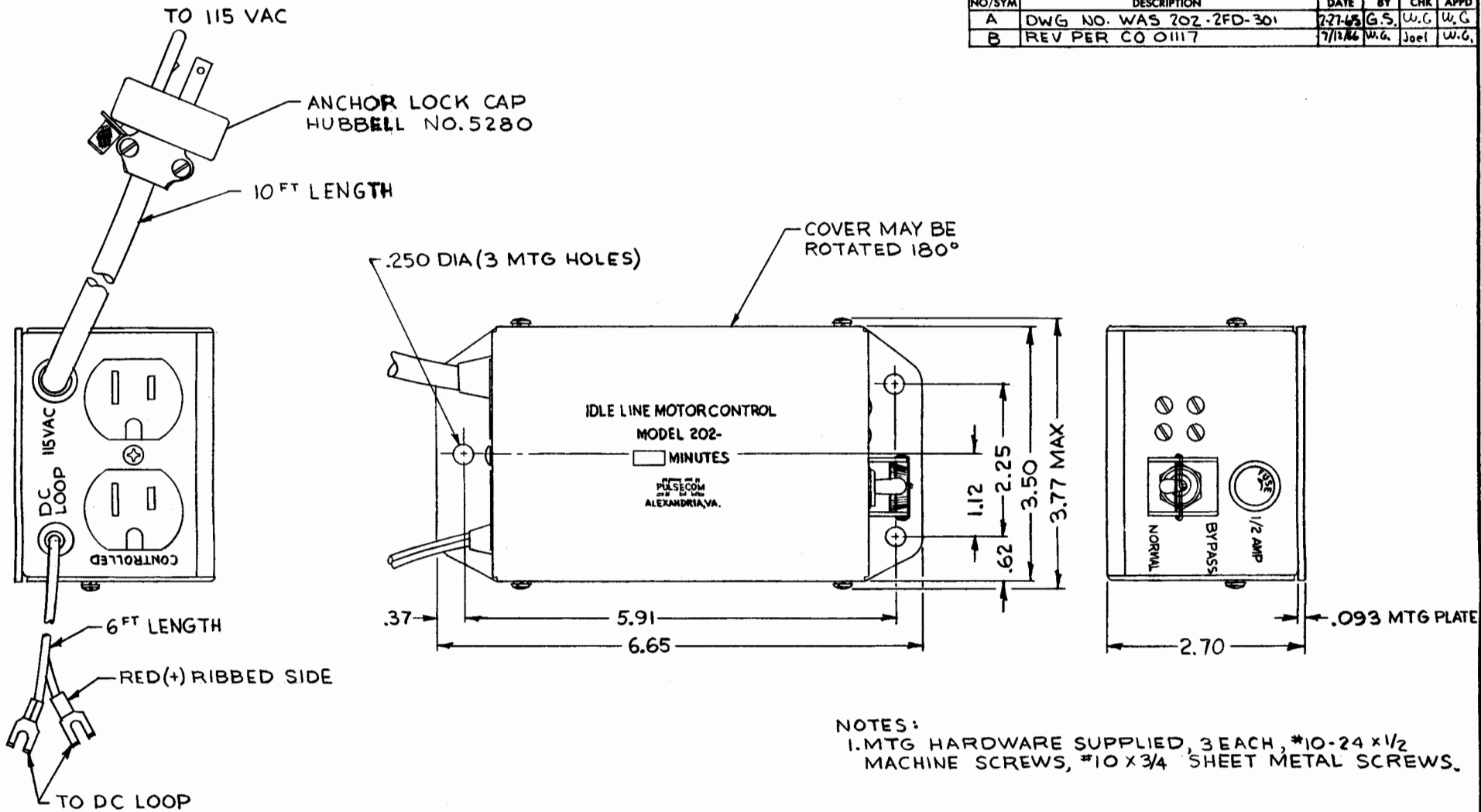

NOTES:
 1. MTG HARDWARE SUPPLIED, 3 EACH, #10-24 x 1/2
 MACHINE SCREWS, #10 x 3/4 SHEET METAL SCREWS.

QTY REQD	MANUFACTURER OR SUPPLIER	PART OR IDENT NUMBER	ITEM	NOMENCLATURE OR DESCRIPTION	NOTES & REF DESIGNATIONS
-1	LIST OF MATERIAL				
UNLESS OTHERWISE SPECIFIED DIMENSIONS ARE IN INCHES		GLEADALL, W. L. 14 DEC 64		 PULSE COMMUNICATIONS, INC. ALEXANDRIA, VA.	
TOLERANCES:		DRAWN DATE 12/11/64			
2 PLACE DECIMALS ±		CHECKED DATE 1/6/65		OUTLINE (IDLE LINE MOTOR CONTROL) MODEL 202-SERIES	
3 PLACE DECIMALS ±		PROJ ENGRG DATE 1/6/65			
ANGLES ±		PROJ ENGRG DATE 1/6/65			
DO NOT SCALE DRAWING		PROJ ENGRG DATE 1/6/65			
MATERIAL:		CAUTION: UNLESS THIS DRAWING BEARS THE NAME OF THE "PROJ ENGRG." "PROD ENGRG" IT IS PRELIMINARY AND UNDER NO CIRCUMSTANCES IS IT TO BE USED FOR MANUFACTURING PURPOSES.		CODE IDENT NO.	SIZE DRAWING NUMBER
FINISH:		THIS DRAWING IS FURNISHED FOR ENGINEERING INFORMATION AND REFERENCE ONLY. THE FURNISHING OF THIS DRAWING DOES NOT CONVEY ANY REPRODUCTION OR MANUFACTURING RIGHTS.		22818	C C 400002
				SCALE: 1/1	SHEET

NO./SYM		DESCRIPTION	DATE	BY	CHK	APPD
E		REDRAWN (REV ADDED CR16)	3/17/65	W. E. S.		

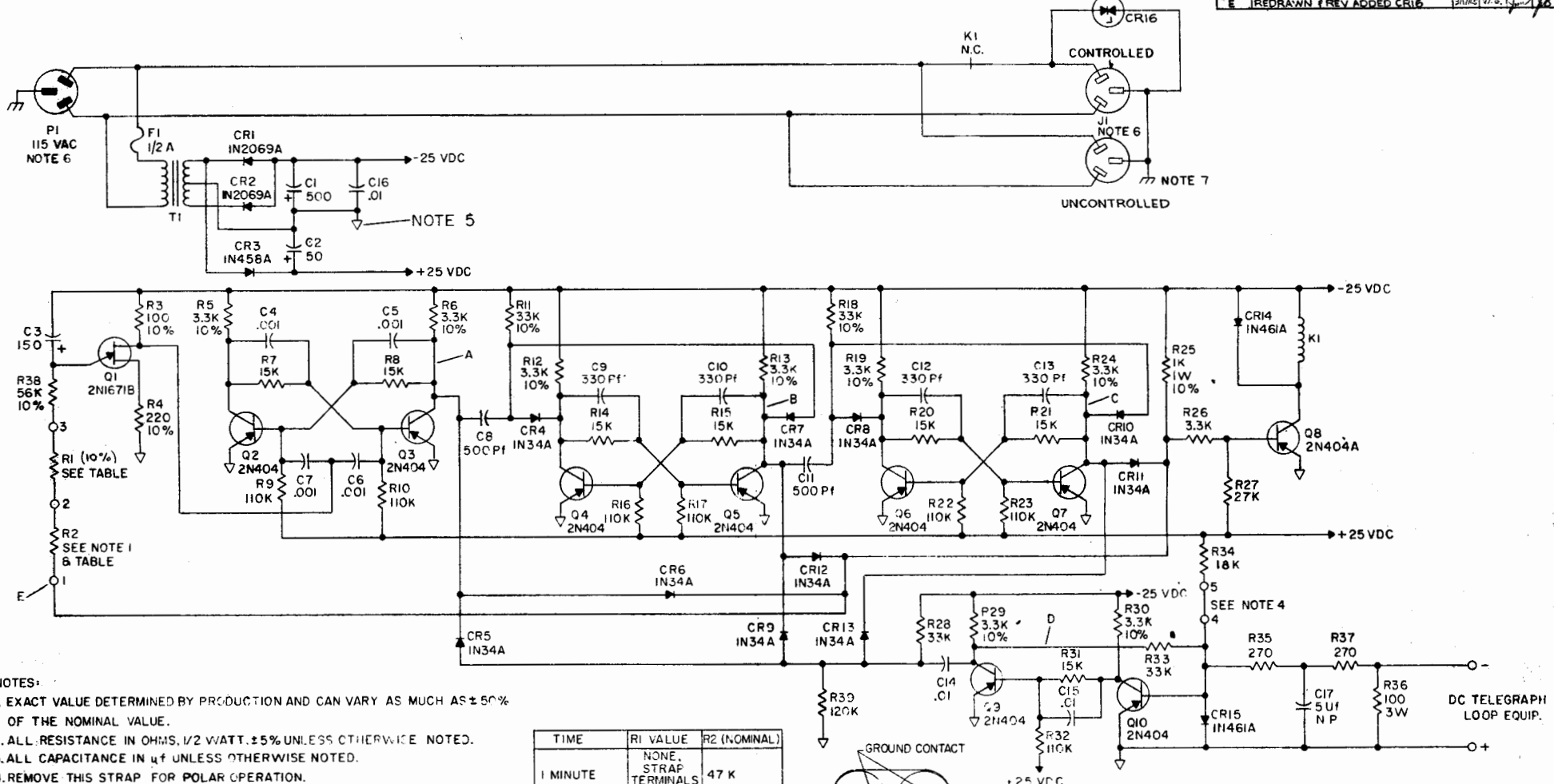

- NOTES:
1. EXACT VALUE DETERMINED BY PRODUCTION AND CAN VARY AS MUCH AS $\pm 50\%$ OF THE NOMINAL VALUE.
 2. ALL RESISTANCE IN OHMS, 1/2 WATT, $\pm 5\%$ UNLESS OTHERWISE NOTED.
 3. ALL CAPACITANCE IN μf UNLESS OTHERWISE NOTED.
 4. REMOVE THIS STRAP FOR POLAR OPERATION.
 5. POINTS MARKED A, B, C, D BE ARE TEST POINTS WITH REFERENCE TO CIRCUIT GROUND ONLY.
 6. "J" "B" "PI" ARE OF THE POLARIZED PARALLELED TYPE. "JI" IS AS SHOWN IN DETAIL "A". "PI" WILL MATE WITH THIS RECEPTACLE.
 7. THIRD WIRE GROUND TIED TO CHASSIS.

TIME	R1 VALUE	R2 (NOMINAL)
1 MINUTE	NONE, STRAP TERMINALS 2 & 3	47 K
5 MINUTES	220 K	220 K
10 MINUTES	470 K	390 K
15 MINUTES	1 MEG	390 K
20 MINUTES	1.2 MEG	620 K

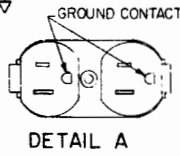

QTY	MANUFACTURER OR SUPPLIER	PART OR IDENT NUMBER	ITEM	NOMENCLATURE OR DESCRIPTION	NOTES & REF DESIGNATIONS
1	GLEADALL V.	7/MAR/65			
UNLESS OTHERWISE SPECIFIED DIMENSIONS ARE IN INCHES					
TOLERANCES					
2 PLACE DECIMALS \pm : 0.005					
3 PLACE DECIMALS \pm : 0.001					
ANGLES \pm : 0.001					
DO NOT SCALE DRAWING					
MATERIAL : <small>SEE DRAWING FOR MATERIAL SPECIFICATIONS</small>					
FINISH : <small>SEE DRAWING FOR FINISH SPECIFICATIONS</small>					
LIST OF MATERIAL				PULSE COMMUNICATIONS, INC. ALEXANDRIA, VA.	
SCHEMATIC (IDLE LINE MOTOR CONTROL) (MODEL 202-1)				DRAWING NUMBER D1200008	



IDLE LINE MOTOR CONTROL
MODEL 202-2

20 MINUTES

PULSE
ALEXANDRIA, VA

BELL SYSTEM PROPERTY

NORMAL
1 AMP
2 AMP



IDLE LINE MOTOR CONTROL
MODEL 202-2

20 MINUTES

DESIGNED BY R. H. PETERSON
ALEXANDRIA, VA.

BELL SYSTEM PROPERTY

CONTROLLED

LOOP

115 VAC