

INSTALLATION INSTRUCTIONS FOR THE 178728 MODIFICATION KIT TO PROVIDE AN IMPROVED CHARACTER COUNTER FOR THE MODEL 28 KEYBOARD (LAK)

The chart below pertains to Bell System only:

Teletype Unit	Teletype Code	Bell System Reference	Bell Code
Keyboard	LAK	Perforator Trans. Base	28A and up

1. GENERAL

a. The 178728 Modification Kit provides an improved character counter for the Model 28 Keyboard (LAK). The kit includes all the necessary parts for field conversion of the LAK Keyboard Character Counter.

b. Operational failures in the field have resulted from a bind of the nylon pulleys on their bearings due to a taut cord. The taut cord is brought about by the characteristic expansion of the nylon pulleys and the shrinkage of the dacron cord under varying atmospheric conditions. The above problems are eliminated by the 178728 Modification Kit since the cord is no longer wound around both pulleys. The return spring is attached to the left end of the indicator, routed over the idler pulley, and attached to a spring terminal mounted under the contact assembly.

c. An improved 155960 Latch and 155964 Stop Lever are included in this kit. Their black appearance distinguishes them from the standard nickel plated parts.

d. The 178728 Modification Kit consists of:

1	104807	Washer, Flat	1	178725	Spring
1	110743	Washer, Lock	1	178726	Bracket, Spring
1	151152	Screw	1	178849	Cord Assembly, Indicator
1	155960	Latch	1	178851	Pulley
1	155964	Lever, Stop	1	179258	Bracket, Scale W/Stud

e. For part numbers referred to and for parts ordering information see Teletype Model 28 Parts Bulletin 1169B.

2. INSTALLATION (See Figure 1.)

a. Remove the two 153799 Screws from the 158019 Baffle. Remove and discard the 158019 Baffle, 158047 Scale and 158046 Bracket and all associated mounting hardware.

b. Remove and discard the 158051 Pulley and 158045 Stud by removing the 3598 Nut, 2191 Lock Washer and 7002 Flat Washer. Retain the mounting hardware.

c. Carefully remove the 152839 Spring from the old 155960 Latch. Remove the 3606 Nut and 1118 Shoulder Screw and retain. Discard the old 155960 Latch and replace with the improved latch provided, utilizing the mounting hardware retained above.

d. To remove the old 155964 Stop Lever, remove and retain the following mounting hardware: 119662 Screw, 124177 Lock Washer, 151631 Screw, 2191 Lock Washer, 158147 Eccentric Bushing and 155968 Flat Washer. Discard the old 155964 Stop Lever and replace with the improved stop lever provided, utilizing the retained mounting hardware.

*e. Position the 179258 Scale Bracket W/Stud by placing the 178851 Pulley over the 179258 Bracket Stud with its projection toward the 155969 Bracket. Fasten the 179258 Scale Bracket W/Stud to the 155969 Bracket with a 151152 Screw, 110743 Lock Washer and 104807 Flat Washer, provided, on the right end and with a 7002 Flat Washer, 2191 Lock Washer and 3598 Nut, (retained in Para. 2.b. above) on the left end.

*f. Remove and discard the 158054 Indicator Cord Assembly with terminal, 158056 Reset Cord with terminals, and 159340 Ratchet Return Spring by removing the 151659 Screw, 155967 Spring Washer, 158053 Ratchet Drum Clamp and 158052 Switch Cam.

*g. Insert the indicator of the 178849 Indicator Cord Assembly through the enlarged portion of the slot of the 179258 Scale Bracket W/Stud. With the 155965 Ratchet in its fully counterclockwise (zero) position, insert the terminal end of the 178849 Indicator Cord Assembly in the upper slot of 155966 Ratchet Drum. Re-assemble 158052 Cam, 158053 Clamp, 155967 Washer, and 151659 Screw.

h. To install the 178726 Spring Bracket between the 158021 Switch Bracket and the 158050 Contact Switch, remove two each 151685 Screw, 110743 Lock Washer, and 114876 Flat Washer.

i. Install the 178725 Spring as shown in Figure 1.

3. ADJUSTMENTS AND LUBRICATION

a. For adjustment and lubrication procedure refer to standardized information (for other than Bell System see Teletype Model 28 Adjustment Bulletin 250B).

(1) Check the following adjustment:

(a) Stop Lever Adjustment.

1. The 155964 Stop Lever must be adjusted so that a gap of .002 to .010 inch exists between the 158042 Latch Lever and the operating face of the 4th ratchet tooth. The 155960 Latch in its non-operated position must not interfere with the free rotation of the ratchet assembly.

2. Before installing the counter on the keyboard perforator, tighten the 155964 Stop Lever Eccentric Adjusting Nut, finger tight by means of its lock screw. Hold the 158040 Feed Lever out of engagement with the ratchet. Adjust the eccentric until a .002 to .010 inch gap exists between the 4th ratchet tooth and the 158042 Latch Lever. Check to make sure no interference exists between the 155960 Latch and the ratchet stop when the ratchet is rotated.

(b) Character Counter Scale - Add the following to this adjustment: The "point" of the indicator should not touch the scale throughout its entire travel. Carefully form the indicator for some clearance.

(c) Character Counter End-of-Line Switch.

(d) Character Counter Stroke - Requirement should read: Min. 0.006 Inch
Max. 0.015 Inch

(e) Ratchet Drum Assembly Return Spring - Requirement should read 1/2 to 1-1/2 ozs. when indicator is in the 35 position to start the indicator moving.
1-1/2 to 2-1/2 ozs. when indicator points to 70 to start the indicator moving.

*PARTS LIST (Figure 1)

2191	Washer, Lock	155967	Washer, Spring
3598	Nut	155969	Bracket
7002	Washer, Flat	158021	Bracket
104807	Washer, Flat	158050	Switch
110743	Washer, Lock	158052	Cam
114876	Washer, Flat	158053	Clamp
151152	Screw	178725	Spring
151659	Screw	178726	Bracket, Spring
151685	Screw	178849	Cord Assembly, Indicator
155960	Latch	178851	Pulley
155964	Lever, Stop	179258	Bracket, Scale. W/Stud
155965	Ratchet		

*

*

*

FIGURE 1

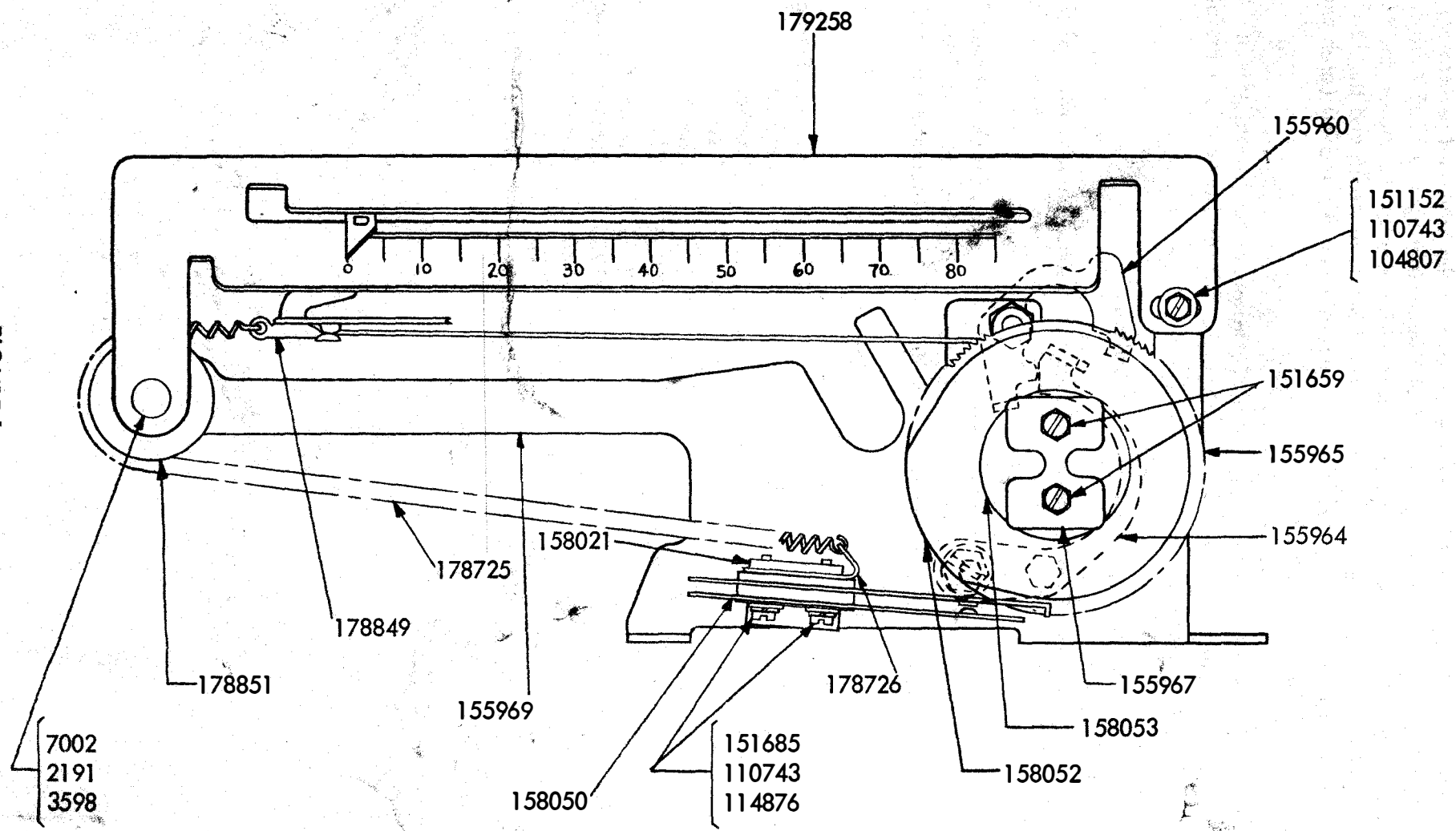

500805