

BELL SYSTEM PRACTICES
Teletypewriter Stations

SECTION P36.619
Issue 4, June, 1953
AT&T Co Standard

↵

**SPROCKET-FEED
END-OF-LAST-FORM
AND PLATEN-INDEXING
MECHANISMS FOR 15 TYPING UNIT
REQUIREMENTS, PROCEDURES
AND LUBRICATION**

Table of Contents	Paragraphs
1. General	1.01-1.02
Cleaning	Section P30.010
2. Sprocket-Feed Mechanism	2.01-2.12
(A) Requirements and Procedures	2.01-2.12
Lubrication	Section P36.601
3. End-of-Last-Form Indicating Mechanism.....	3.01-3.08
(A) Requirements and Procedures	3.01-3.06
(B) Lubrication	3.07-3.08
4. Platen-Indexing Mechanism	4.01-4.09
(A) Requirements and Procedures	4.01-4.09
(B) Lubrication	4.07-4.09
15 Typing Unit	
Requirements and Procedures	Section P36.610
Lubrication	Section P36.601 ↵

1. GENERAL

1.01 This section gives requirements and procedures and lubrication instructions for the:

- (1) Sprocket-Feed Mechanism
- (2) End-of-Last-Form Indicating Mechanism
- (3) Platen-Indexing Mechanism

These parts are used on the 15 typing unit.

1.02 It is reissued to add adjusting and lubrication information for the End-of-Last-Form and the Platen-Indexing Mechanisms.

2. SPROCKET-FEED MECHANISM

(A) Requirements and Procedures

2.01 **Platen-roller sprocket rings** should be firmly against the ends of the platen covering and should locate the paper so that the bottom of a typed line of letter "N" is $\frac{1}{32}$ " plus or minus $\frac{1}{64}$ " above a line tangent to the lower edge of the perforation in the paper as in Fig. 1, or to type on a line to meet the requirements of the stationery used.

Fig. 1

- (a) To adjust, reposition the sprocket rings.

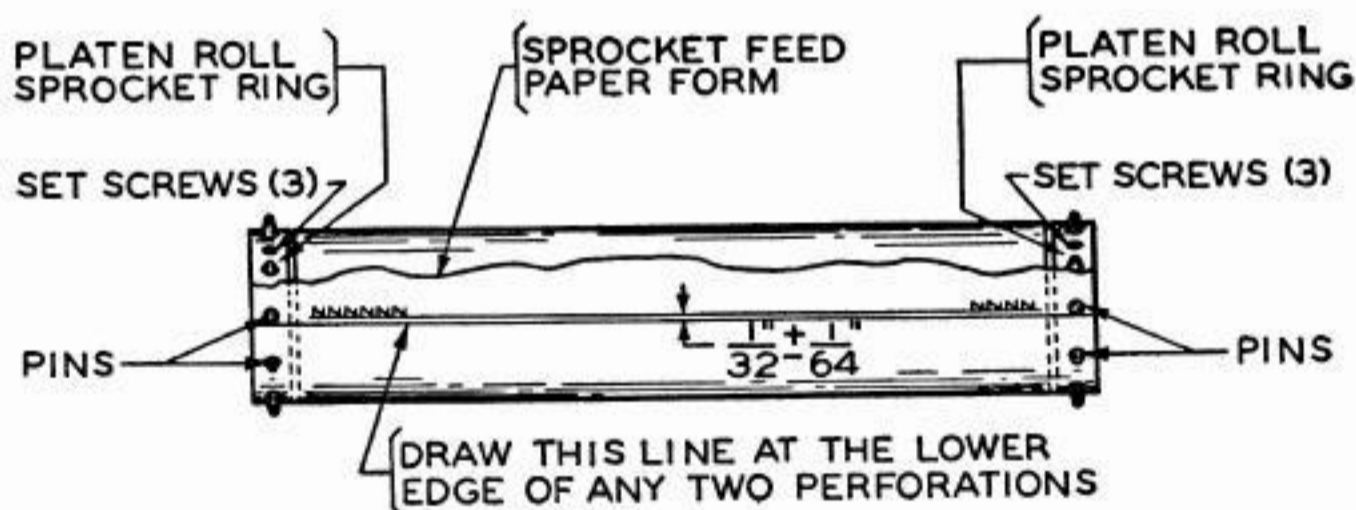

Fig. 1.

2.02 **Left pressure roller** should (1) rest against the platen when an R wrench (.125" thick) is placed between the platen and the knurled surface of the right pressure roller and (2) be located so that the center of its groove lines up with the center of the sprocket pins as in Fig. 2 when the roller is at the midpoint of its end-play.

Fig. 2

(a) To adjust, reposition left pressure-roller lever.

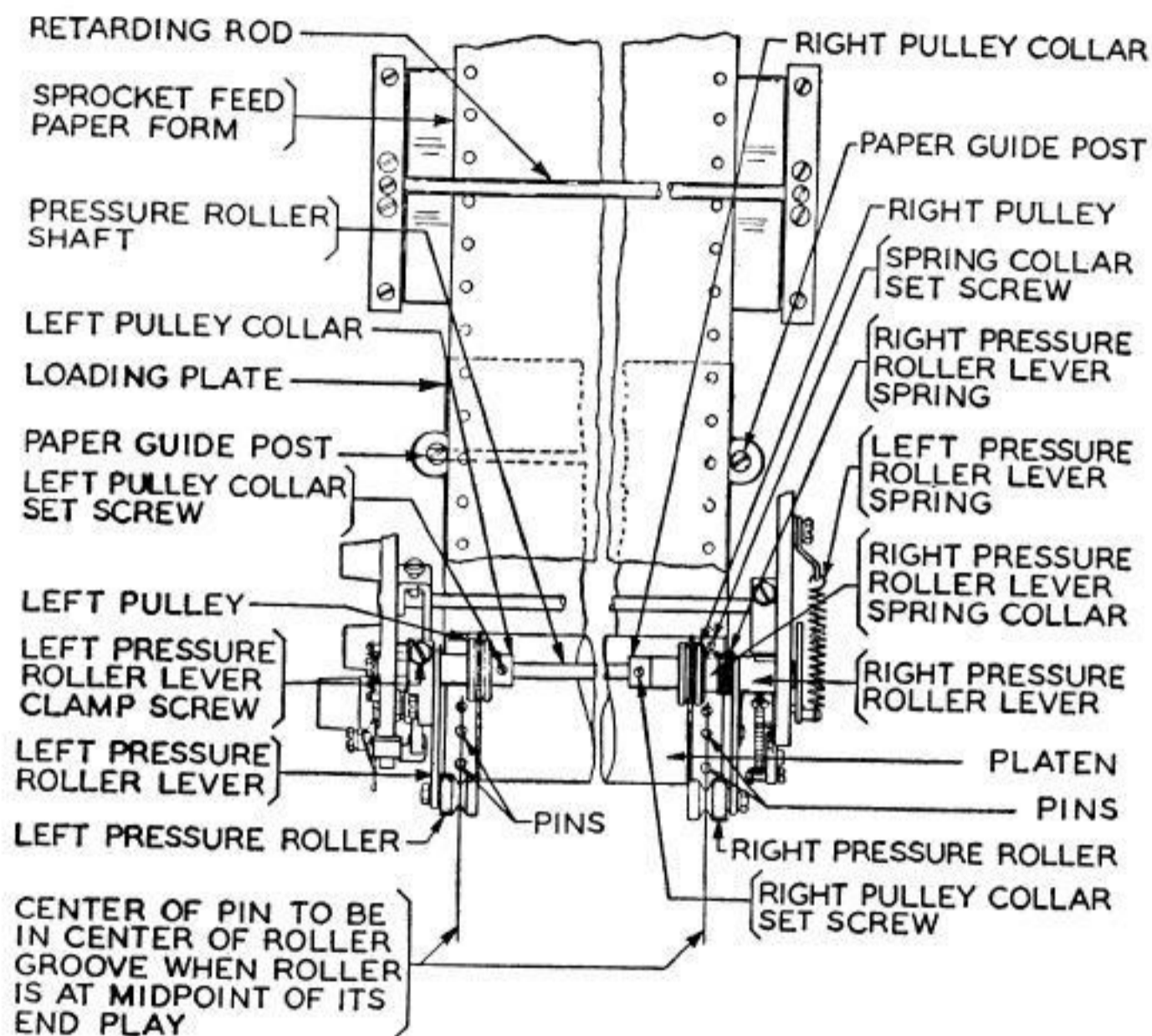

Fig. 2.

2.03 **Right pressure-roller lever** should have end-play not to exceed .002" and, when pressed against its spring collar, the center of the roller groove shall line up with the center of the sprocket pins as in Fig. 2 when the roller is at the midpoint of its end-play.

Fig. 2

(a) To adjust, reposition right pressure-roller-lever spring collar.

SPROCKET-FEED
END-OF-LAST-FORM
AND PLATEN-INDEXING
MECHANISMS FOR 15 TYPING UNIT
REQUIREMENTS, PROCEDURES
AND LUBRICATION

2.04 **Left and right pressure-roller-lever springs** should have tensions of Min 5 oz (140 gm), Max 8 oz (225 gm) measured at the left and right pressure bearing-screw nuts respectively, as in Fig. 3, when their respective pressure rollers start to move from platen. **Fig. 3**

(a) To adjust, rotate right pressure-roller-lever spring collar on its shaft until tensions of both springs are within limits and then recheck 2.03.

Note: If tensions of springs cannot be brought within limits by adjusting right pressure-roller-lever spring collar replace left pressure-roller-lever spring.

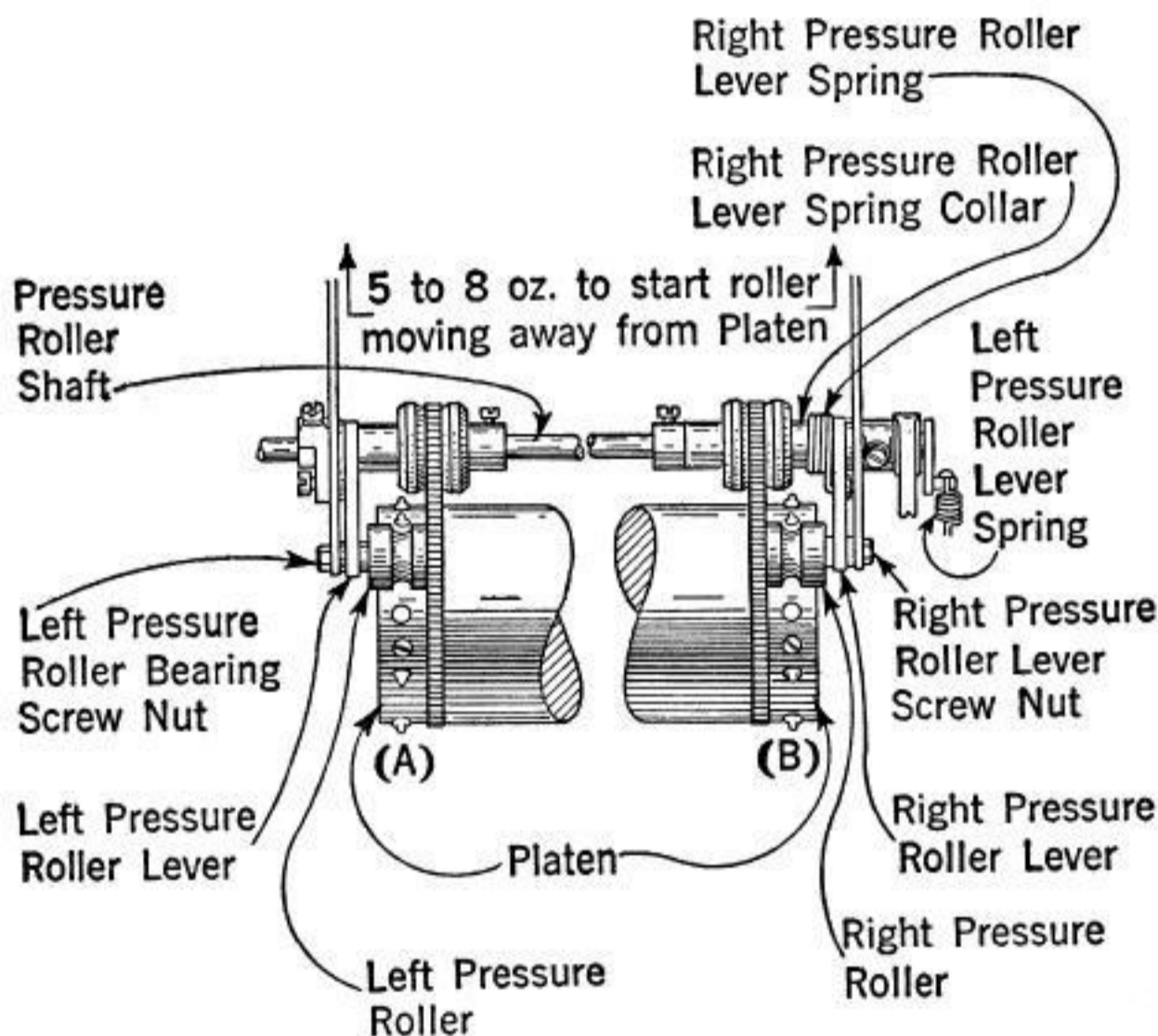

Fig. 3.

2.05 **Paper carrier belt pulleys** should have end-play not to exceed .010".

(a) To adjust, reposition pulley collars.

2.06 **Wire paper stripper** (an improved part superseding paper carrier belts of Fig. 2 and Fig. 3): There should be some clearance, not more than .020", between the front pro-⁷

jection of the strippers and the bottom of the platen groove when the rear projection is held against the platen groove. To adjust, bend the strippers to meet the requirement. ↵

2.07 **Paper-Stripper Locating Collars:** There should be some clearance, not more than .006", between the strippers and the platen-roll sprocket rings when the strippers are held against their locating collars. Under these conditions there should be at least .004" between the strippers and the rubber side of the grooves in the platen. Check over one complete revolution of the platen for each stripper.

(a) To adjust, reposition the locating collars.

2.08 **Left Margin:** First character of a line should be typed within 1/16" of the margin specified in the service order.

Note: For 73 or less characters per line, the left edge of the first character should ordinarily be typed 3/8" from the centerline of the sprocket holes (nominally 5/8" from edge of paper). For the maximum of 74 characters per line, the left edge of the first character should be typed 9/32" from the centerline of the sprocket holes, making sure that the left edge of the first character does not type over the carrier belt groove.

(a) To adjust, reposition the left margin-adjusting screw as outlined under Left Margin Adjustment in Section P36.610 using the left edge of letter M for a reference line.

Note: Where it is desired that the typing be located more accurately with reference to a vertical column line on a form, the platen unit may be shifted as much as .030" to left or right of its standard adjustment, given in P36.610, by means of its pivot screws provided care is taken to see that the platen unit does not interfere with either side frame. If more than .030" adjustment is required the typing point may be shifted .050" by shifting the engagement of the spacing and main-shaft gears one tooth of the spacing-shaft gear. To do this, place carriage in extreme left position, loosen spacing-shaft top-bearing retaining plate, raise spacing shaft until gears disengage, turn shaft clockwise one tooth and reassemble spacing-shaft and retaining-plate. **If typing point is shifted by either or both of these methods recheck left margin-adjustment and line-feed link and shift link for bind.**

2.09 **Platen-friction assembly** should require a pull of Min 14 oz (395 gm), Max 16 oz (455 gm), applied as in Fig. 4, to start the platen rotating when the pressure rollers

are lifted off the platen, the line-feed detent-lever spring is unhooked, the platen-handle is placed vertically upward and 1 to 3 copies of sprocket-feed paper forms are used. **Fig. 4**

Note: When 4 to 6 copies are used, pull required should be Min 10 oz (285 gm), Max 12 oz (340 gm).

- (a) To adjust, reposition adjusting nuts of the friction assembly.

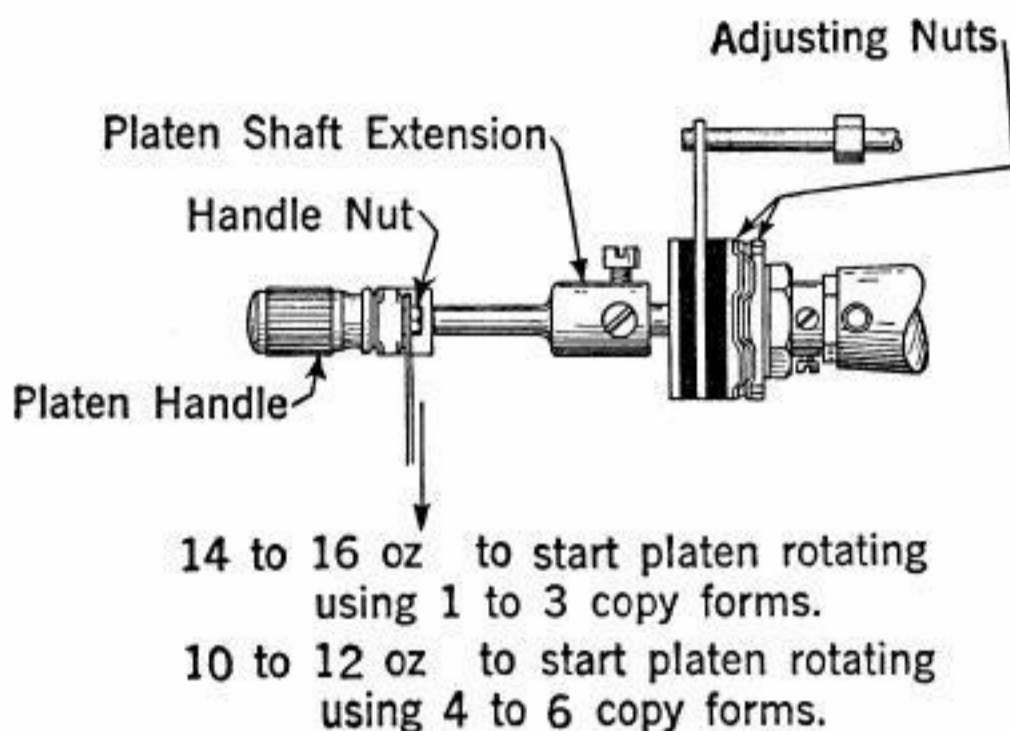

Fig. 4.

- 2.10 **Right Margin:** Recheck in accordance with Section P36.610.

Note: **After all adjustments on the typing unit, base and keyboard have been made, place cover on teletypewriter.**

- 2.11 **Loading-plate paper-guide posts** should just clear the edges of the forms. **Fig. 2**

- (a) To adjust, reposition posts in slotted holes.

Note: Load teletypewriter with stationery as follows:

Stapled Forms. Set the container of forms on the floor or in the 15A paper box at the rear of the teletypewriter. With a paper clip near each edge of the leading form set to hold the several sheets together, thread the forms between the paper guide strip and the cover paper guide, through the slot in the rear of the cover, under the retarding rod on the typing unit, over the loading plate and push the leading edge under the platen. Standing at the right side of the machine, with the index finger of the left hand press

the leading edge of the forms to the platen at a point near the ribbon guide and turn the platen crank with the right hand until the forms have emerged sufficiently to pull them through. Lift the pressure rollers and set the forms on the sprocket pins. Lower the pressure rollers. Go to the rear of the machine and pull the form assembly down lightly to remove slack.

Loose Forms. Stationery in which sprocket holes are the sole means for maintaining alignment between the carbons and the several sheets requires different treatment for feeding through the machine. Forms of this type should not be fed from the floor but should emerge from the container which is at a height sufficient to bring the top just below the slot in the rear of the cover. These forms should feed into the cover over the top rounded portion of the cover guide plate and instead of threading through the retarding rods they should pass over them directly over the loading plate to the platen.

Special Forms. Some form assemblies are made up of combination loose and stapling design which may require different placement of the container. It is recommended that forms of special design be installed on a trial basis, cooperating with a representative of the stationery supplier under actual service conditions. If difficulty is encountered in securing satisfactory paper feed the problem should be referred along the channels of organization.

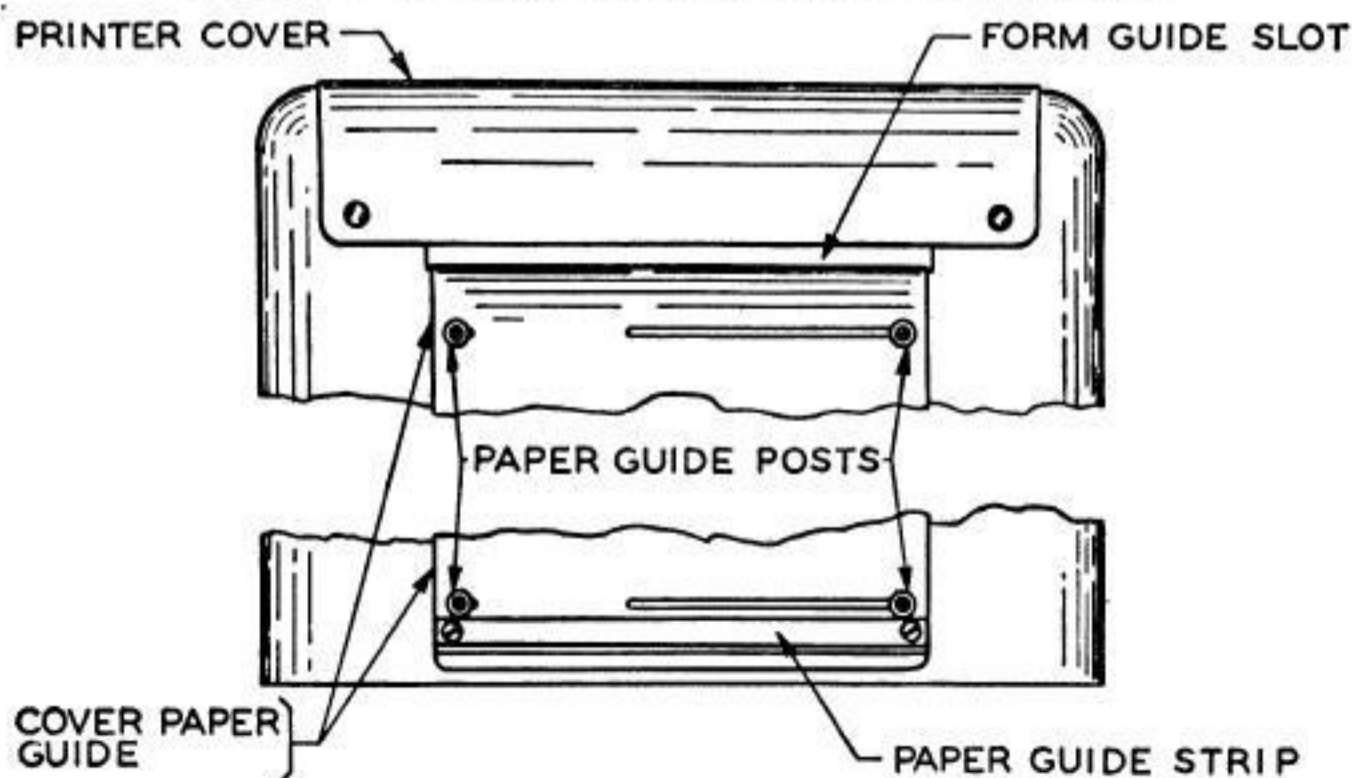

Fig. 5.

SPROCKET-FEED
END-OF-LAST-FORM
AND PLATEN-INDEXING
MECHANISMS FOR 15 TYPING UNIT
REQUIREMENTS, PROCEDURES
AND LUBRICATION

2.12 **Cover paper guide posts** should just clear the edges of the forms when the sprocket pins are in the proper holes of the forms so as to hold the paper straight and the slack in the forms is taken up by grasping them just below the paper guide. **Fig. 5**

- (a) To adjust, reposition guide posts in cover paper guide. Recheck 2.11.

3. END-OF-LAST-FORM INDICATING MECHANISM ↵

(A) Requirements and Procedures

3.01 The TP115847 set of parts provides the 15 sprocket-feed typing unit with an alarm feature indicating when the end of the last form has reached the printing point. The alarm may be given in any one of numerous ways, by bell, buzzer or light. This set of parts consists essentially of a paper-out bail and a bracket on which is mounted a switch. The parts are designed so they can be attached to the right platen side frame. When the end of the last form clears the paper-out bail, the arm of the bail drops into a groove at the right end of the platen. The other end of the bail operates a switch which results in an alarm signal. An alarm signal also results when the pressure rollers are raised for the insertion of new forms. The switch may be wired to produce the alarm either by opening or closing an external circuit.

3.02 **Line-Feed Detent-Lever**

See Section P36.610

3.03 **Paper-Out Bail.** The vertical arm of the paper-out bail should drop freely into the platen groove. To adjust, add or remove shims. **Fig. 6 and Fig. 7**

3.04 **Paper-Out-Bail Spring.** The spring should be anchored in the center of the three holes in the bushing. **Fig. 7**

3.05 **Vertical-Link-Eccentric**

See Fig. 6

Fig. 6 ↵

END-OF-LAST-FORM INDICATING MECHANISM

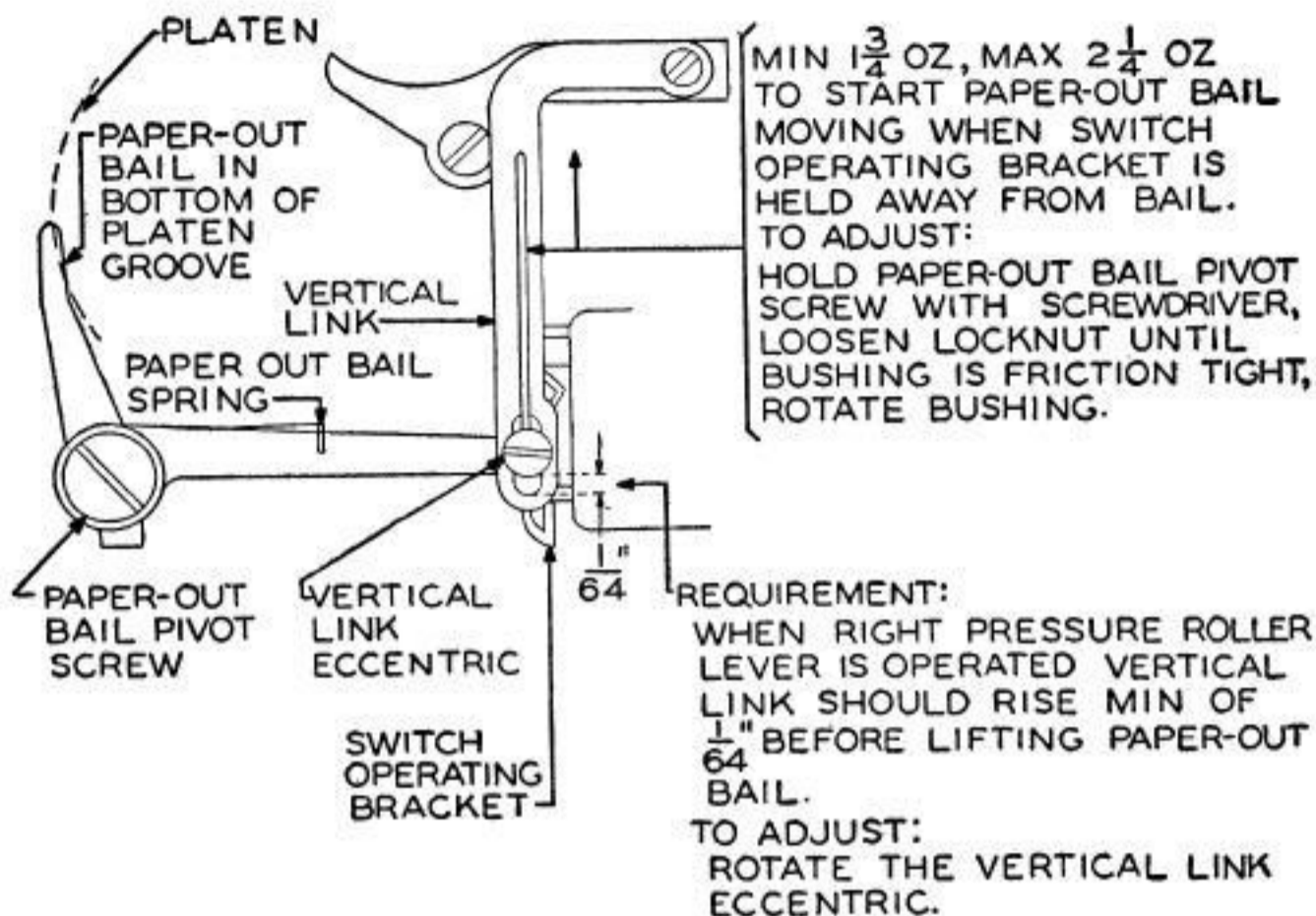

Fig. 6.

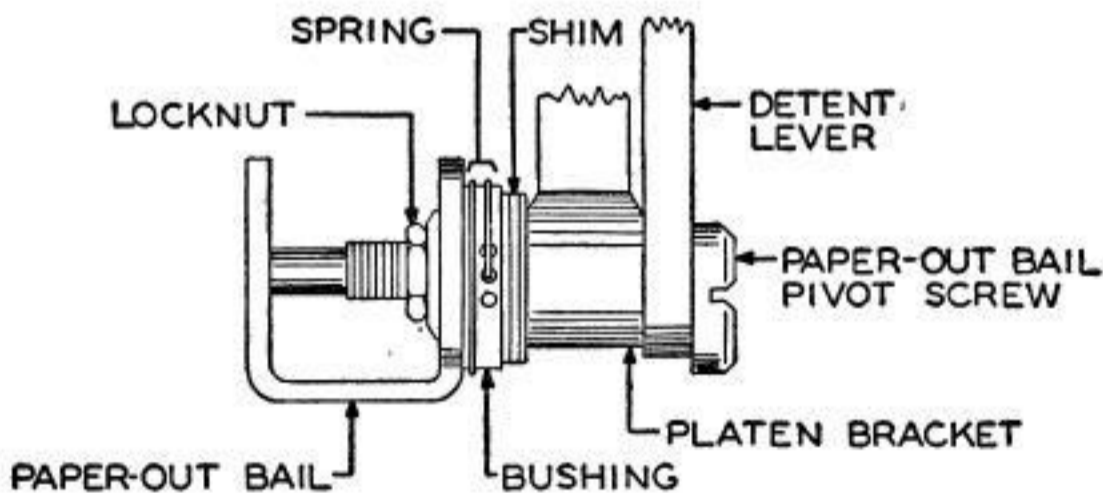

Fig. 7.

3.06 Switch Mounting-Plate. When the vertical arm of the paper-out bail is on the outer paper surface, the bail camming surface should be on the flat of the switch-operating bracket and should push in the plunger to just operate the switch. The switch should be unoperated (plunger out) under either of two conditions:

- (1) When the end of the last form clears the paper-out bail.

- (2) When the pressure rollers are raised as for the insertion of new forms.

To Adjust, loosen the switch-plate mounting-screws and position the plate.

Note: To prevent thin sheets of paper from tearing, the camming surface of the paper-out bail should never be below the peak of the projecting surface on the switch-operating bracket when the paper is in the machine.

(B) Lubrication

3.07 Oil:

- (1) Two pivot points on the paper-out bail.
- (2) Switch-operating bracket arm.
- (3) All shoulder-screws.

3.08 Grease Sparingly:

- (1) Reset-lever camming surface.

4. PLATEN-INDEXING MECHANISM

(A) Requirements and Procedures

4.01 The TP121130 set of parts provides a platen-indexing feature for the sprocket-feed 15 typing unit. Included in the set of parts is a switch to open and close a circuit to provide an indication that all receiving units have their forms aligned for printing at a predetermined line.

4.02 The particular arrangement of the indicating circuit is a matter for local determination.

4.03 With the contact lever engaged in its cam indent, the switch should operate, and there should be a minimum clearance of .010" between the top of the switch case and the operating lever.

(a) To Adjust:

- (1) Loosen the gear-adjusting-plate clamp-screw.
- (2) Raise the plate extension as far as possible.
- (3) Retighten the clamp-screw.

Note: There are two positions of the eccentric. The position toward the front of the unit should be used.

4.04 **Removable Gears.** There should be a perceptible amount of backlash in the two outer gears.

(a) To Adjust:

- (1) Loosen the gear-adjusting-plate clamp-screw and rotate plate.

- (2) Retighten the clamp-screw.

Note: The backlash should be determined by holding the platen stationary and rotating the idler-gear-assembly. Check this adjustment for one full revolution of the larger removable gear.

4.05 **Cam-Clutch Torque.** With the thumb-wheel rotated counterclockwise and the right-hand stop-screw against the stop pin, it should require Min 44 oz applied in a horizontal position at the drop-off point of the cam to rotate the cam counterclockwise.

(a) **To Adjust:**

- (1) Remove the two stop-screws from the thumb-wheel.
- (2) Rotate the thumb-wheel counterclockwise until the cam surfaces are at the top.
- (3) Hold the cam and rotate the thumb-wheel until it requires Min 44 oz tension to start the cam assembly rotating.
- (4) Rotate the thumb-wheel clockwise (if necessary) until the first tapped hole passes to the right side of the stop-pin. (Stop pin positioned at the top.)
- (5) Mount the first stop-screw in this tapped hole.
- (6) Recheck the minimum clutch torque requirement of 44 oz.
- (7) Mount the second stop-screw in the first tapped hole counterclockwise of the first stop-screw.

4.06 **Contact-Lever Spring Tension.** With the contact-lever in the indent of the cam, apply a scale to the contact-lever just below the cam-following surface. When pulling in a horizontal direction it should require 8 to 12 oz to start the lever moving.

(B) Lubrication

4.07 **Oil:**

- (1) Idler-gear stud.
- (2) Clutch washer.
- (3) Cam-assembly stud.
- (4) Cam-assembly bushing.
- (5) Contact-lever pivot.
- (6) Spring ends.

4.08 **Oil-Grease Oil:**

All gears.

4.09 **Grease:**

Cam.