

4278WD

REVISIONS

ISSUE	DATE	AUTH. NO.
1	12-9-55	28-15351
2	2-21-51	55051
3	4-7-51	55751-24
4	3-25-52	55755-10
5	10-31-52	73713-1
6	4-9-53	75557
7	9-10-53	73713-2
8	2-1-56	90183
9	9-29-66	92120WD

- NOTES
1. WIRING LEGEND:
  2. COLOR CODE:  

BR-BLACK	R-RED
DR-DROWN	Y-YELLOW
BL-BLUE	G-GREEN
P-PURPLE	W-WHITE
O-ORANGE	S-SLATE
  3. UNIT WIRED FOR 115 VOLTS, 50 TO 60 CYCLE AC POWER INPUT ONLY.
  4. PLEAS VIEWED FROM SOLDER TERMINAL ENDS.
  5. CIRCUITS SHOWN FOR .020 AMP. NEUTRAL SIGNAL LINE OPERATION. FOR .020 AMP. OPERATION REMOVE AND ADD CONNECTIONS AS FOLLOWS:  

SIGNAL LINE CURRENT	CONNECTIONS REMOVED	CONNECTIONS ADDED
.020 AMP.	B1-BR, A2-A2	A1-A2

\*PLACE TWO STRAPS IN PARALLEL.
  6. RECTIFIER SHOWN CONTROLLED BY POWER SWITCH FOR CONTINUOUS OPERATION REMOVE LEAD C-2-BK AND C-8-W FROM TERMINAL L-2 AND L-7 AND CONNECT TO TERMINAL Q5 AND Q2 RESPECTIVELY.
  7. SET MUST BE GROUNDED THROUGH THE SHIELDING PROVIDED IN THE ELECT. NOISE SUPPRESSOR PRIOR TO BEING OPERATED.
  8. REFER TO 4222WD FOR INTERNAL WIRING OF THE 17266B ELECTRONIC RELAY SHIFT UNIT. (THIS UNIT IS USED FOR THE "GOBLIN" APPLICATION ONLY.)
  9. TAPE ON THE STRAPS TO RESISTOR.
  10. SPLICE CABLE ON TO TRANSFORMER LEADS.

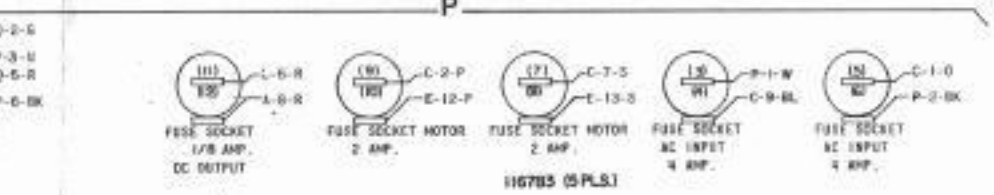
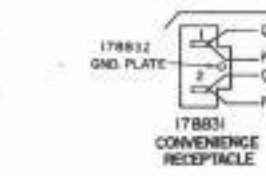
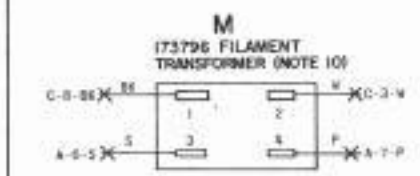
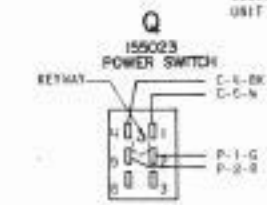
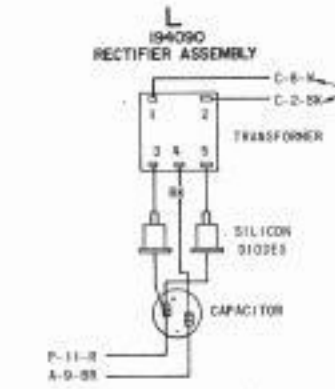
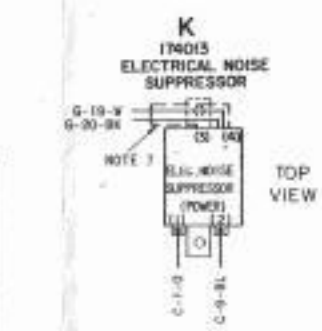
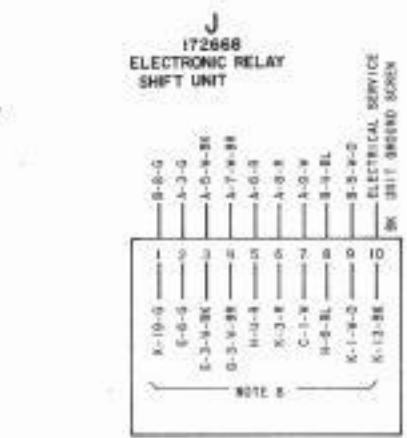
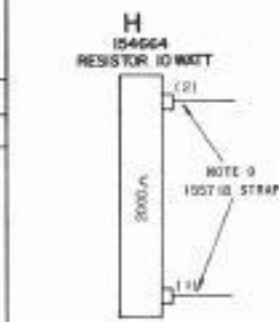
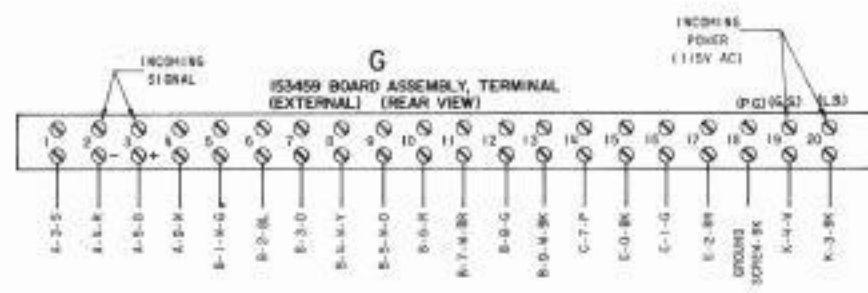
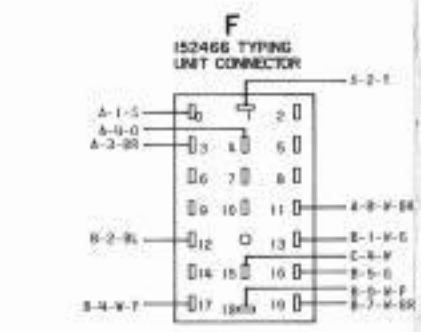
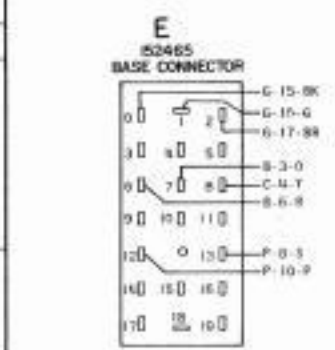
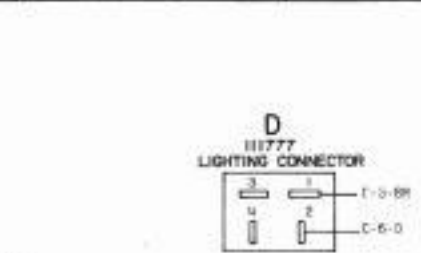
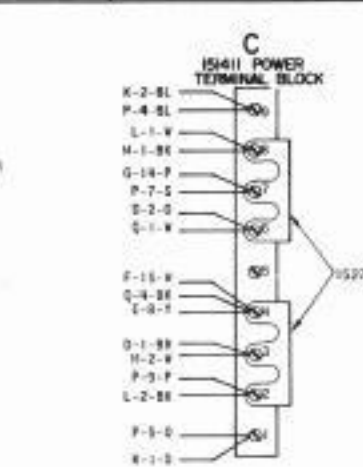
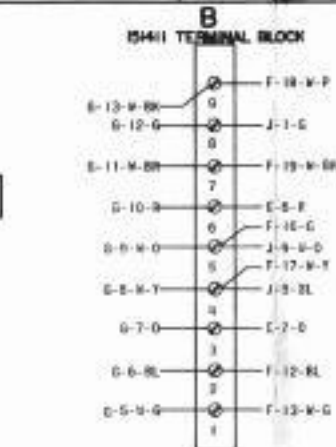
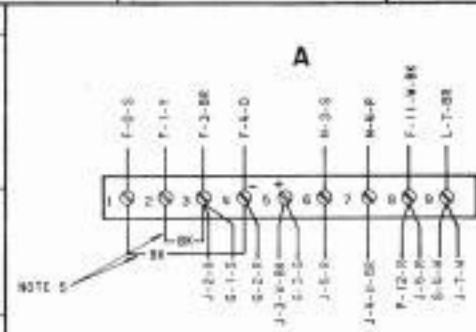

ACTUAL WIRING DIAGRAM FOR ELECTRICAL SERVICE UNIT LESSS

APPROVALS

D AND R	E OF M
<i>APX</i>	<i>[Signature]</i>

C-NUMBER  
 PROD. NO. 4278WD  
 DATE 10-10-60  
 P.D. FILE NO. 33.20.55AA  
 DRAWN J.A.P. CHKD.  
 ENGR. R.A.P. APPD. E.L.C.

TELETYPE CORPORATION  
 4278WD