

DESCRIPTION, ADJUSTING AND ORDERING INFORMATION
TELETYPE MODEL REC-30 RECTIFIER

(For Multi-Voltage Multi-Frequency Operation)

DESCRIPTION

The Model REC-30 rectifier power unit is designed to provide filtered direct current suitable for the operation of Teletype signal circuits and to provide the proper A.C. voltage for the operation of series governed motors, when connected to A.C. sources of various voltages and frequencies. The input requirements and the output rating are as follows:

Input: 95, 105, 115, 125, 190, 210, 230, or 250 volts, 25, 40, 50, or 60 cycles, single phase A.C.

Output: 0.9 amperes at 120 volts D.C. (No load voltage not to exceed 130 volts.)

Also

A.C. at suitable voltage for the operation of three series governed motors at frequencies of 25, 40, 50 or 60 cycles.

The power unit consists essentially of an auto-transformer, necessary control and filament windings for the operation of the grid control rectifier network, an insulating type plate transformer, suitable radio interference filters on both A.C. input and D.C. output circuits, D.C. output filter consisting of a choke and two condensers, resistor network, two grid controlled rectifier tubes, one voltage standard tube, and one amplifier tube. All of these parts are secured to a metal base which has metal feet for shelf mounting.

The power unit is designed for use in tropical climates and is furnished complete with cover, terminal panels, and cords and plugs for making A.C. input, A.C. output for series governed motors and D.C. output connections.

The case is finished in black baked wrinkle enamel.

The approximate dimensions of the power unit are 25" long, 8" wide and 11" high. The approximate net weight is 110 lbs.

Double Pole Power Switch

The double pole power switch, when thrown in the "OFF" position, completely isolates the fuses and flexible leads from the A.C. supply.

CAUTION: Throw switch to "OFF" position before opening hinged door of rectifier cover.

*Same as issue 3 except changes in Wiring Diagram and assembly drawing.

Any terminal on the main terminal panel may be 250 volts above ground potential with switch in the "ON" position.

Main Terminal Panel

The main terminal panel, which is located directly behind the hinged door in the cover, contains terminals for A.C. input taps, A.C. output taps, fuses and potentiometer. The A.C. input taps for the line voltages of 95, 105, 115, 125, 190, 210, 230 and 250 volts are located on the top and left-hand side of the panel. The A.C. output taps to proper adjusted voltage for operating series governed motors on frequencies of 25, 40, 50 or 60 cycles are located on the right-hand side of the panel.

Cord and Condenser Terminal Panel

The A.C. input, A.C. output and D.C. output cords and two filter condensers terminate on a panel at the left-front of the rectifier. The cover must be removed to gain access to this panel.

ADJUSTMENTS

Throw the power switch to the "OFF" position and open the hinged door of cover.

CAUTION: The secondary voltage of the transformer is 400 volts. Do not make any adjustments or change any tubes while the unit is in operation.

1. To adjust for A.C. input voltage, connect the flexible lead on the left-hand and top side of the panel to the terminal with the marking which most nearly corresponds to the voltage of the available A.C. supply.
2. To adjust for frequency, connect the flexible lead on the right-hand side of the control panel to the terminal having a marking which most nearly corresponds to the frequency of the available A.C. supply.
3. To adjust the D.C. output voltage, connect a 60 watt, 115 volt Mazda lamp in series with a suitable ammeter across the D.C. output of the rectifier and adjust the potentiometer with screw driver slot located in the center of the tap panel until the ammeter reads 0.5 ampere.

It will be necessary for the rectifier to be connected to the A.C. current supply for approximately twenty seconds before D.C. output will be available. This time delay is necessary for the protection of the grid controlled rectifier tubes. This adjustment should be checked when the unit is installed and periodically thereafter.

The time delay may be adjusted by means of the adjusting screw and lock nut located on the tie bar between the two bi-metal strips.

The time delay relay is located under a metal cover at the top of the door opening. The cover is removable by loosening one screw and sliding the cover off to the right.

The time delay switch contacts should be adjusted by bending so that the D.C. output from the tubes is available before the A.C. output from the auto-transformer.

OPERATION

If the D.C. output fails to become available within approximately one minute after the power switch is turned on, make sure that:

1. The input fuse (lower one on the main terminal panel) is not burned out.
2. The plate transformer fuse (upper one on the terminal panel) is not burned out.
3. The front "make" contact of the relay (contact nearest the door of the cabinet) is in contact with its associated contact.
4. The filaments on both grid controlled rectifier tubes are lit.
5. The bi-metal pulls the relay armature down.

If the bi-metal does not pull the relay armature down check the back contacts (normally closed) of the relay. These contacts in multiple are in series with the primary winding of the heater transformer. If the bi-metal is inoperative and these contacts are making, the heater transformer is probably at fault. The unit may be manually started by depressing the relay armature with a stick or other piece of non-conducting material. Once closed the relay coil will hold in.

If the D.C. output rises considerably or if the rectifier output does not regulate properly, either the neon lamp and/or the amplifier tube may be defective.

If a high enough output voltage cannot be obtained, one or both of the rectifier tubes may need replacement. If the line voltage drops considerably below the A.C. input line voltage setting, the D.C. output voltage will drop. In this case, the lower A.C. input line tap should be used to match the actual line voltage.

In the event that the time delay relay fails to hold down magnetically and the bi-metal remains hot, check relay coil and/or resistor in series with same. This could affect both the A.C. and D.C. outputs.

The actual and schematic wiring of the REC-30 rectifier is shown in the attached drawing W.D. 2204 and assembly drawing showing names and part numbers of the component parts of the rectifier is also furnished.

REVISIONS
 NO. FOR REVISIONS
 1-1-43 28847
 2-15-47 48884
 3-1-48 41841
 4-1-48 40781

SCHEMATIC WIRING

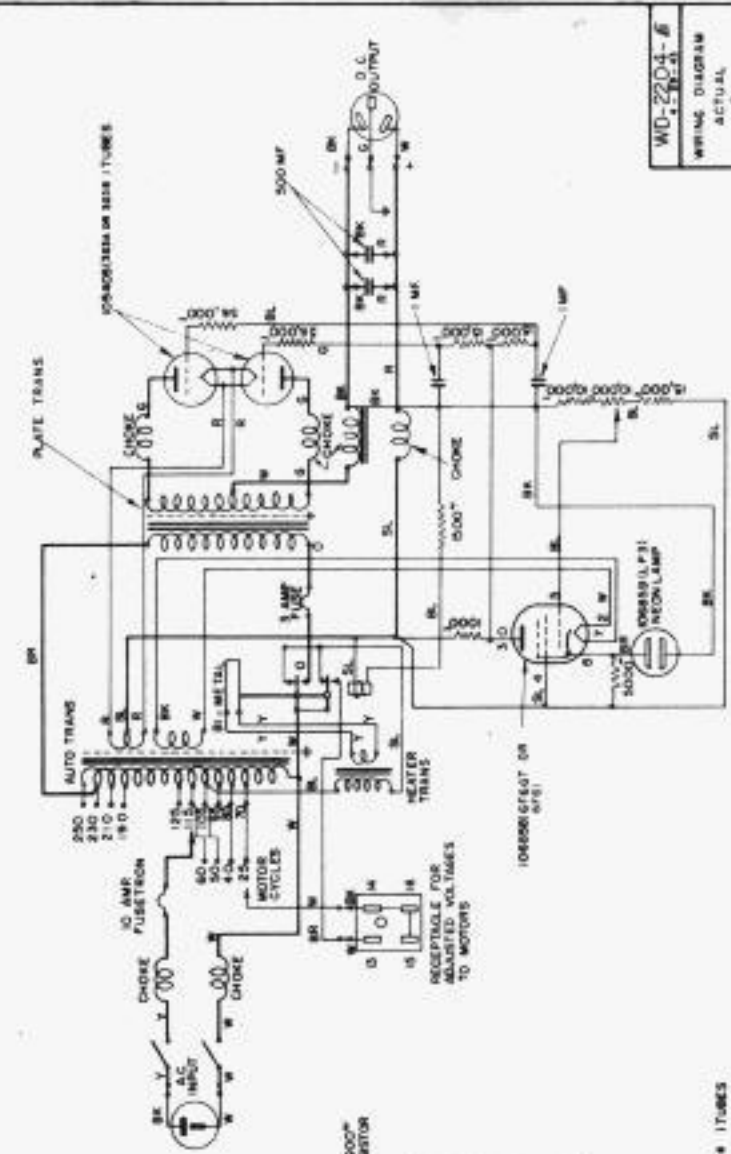

WD-2204-B
 WIRING DIAGRAM
 ACTUAL
 SCHEMATIC
 REC 50

TELETYPE CORPORATION

ACTUAL WIRING

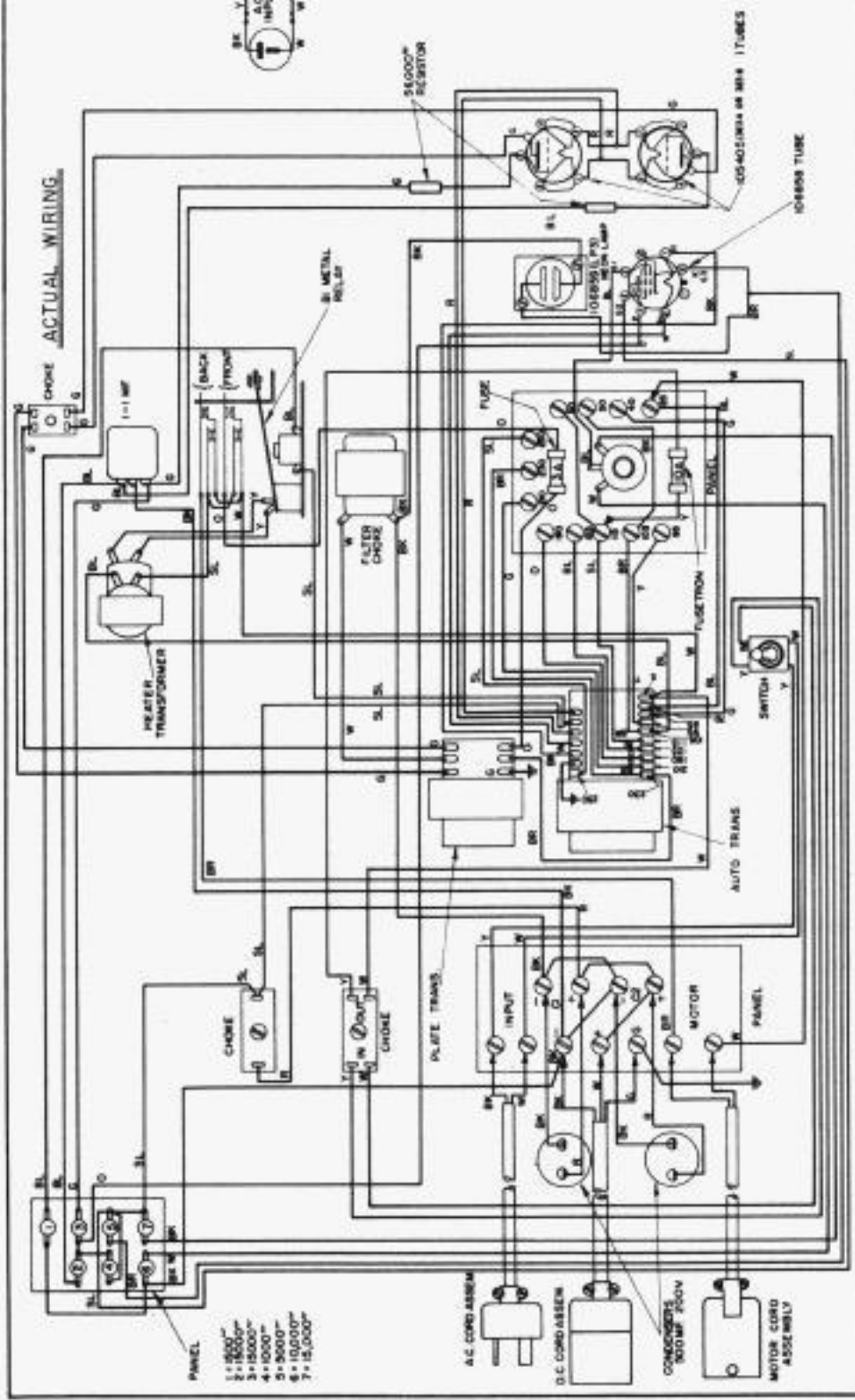

A.C. CORD ASSEMBLY
 D.C. CORD ASSEMBLY
 CONSOLE 250V 500W 250V
 MOTOR CORD ASSEMBLY

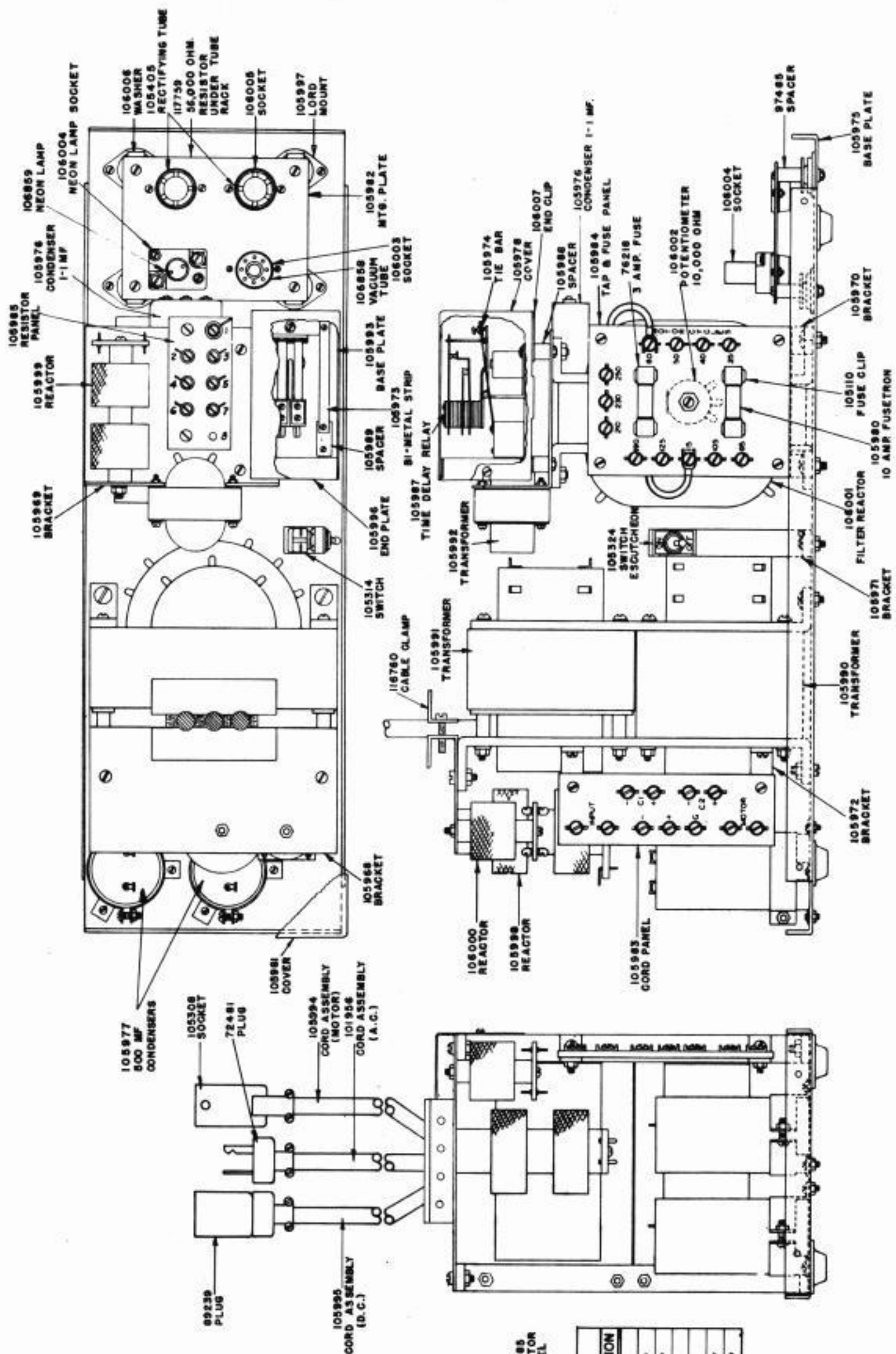

105985
RESISTOR
PANEL

NO	PART NO.	DESCRIPTION
1	103754	1500~
2	106010	15000~
3	106010	15000~
4	106012	1000~
5	106013	5000~
6	106014	10000~
7	106010	15000~