

INSTRUCTIONS FOR INSTALLING THE 164272 MODIFICATION KIT
TO PROVIDE CHAD DISPOSAL FOR THE AUXILIARY REPERFORATOR;
170306 MODIFICATION KIT TO PROVIDE CHAD DISPOSAL FOR THE
KEYBOARD REPERFORATOR; 164405** AND 195391** MODIFICATION
KITS TO PROVIDE CHAD CONTAINER FOR THE AUXILIARY AND/OR
KEYBOARD REPERFORATOR

1. GENERAL

- 1.01 The 164272 modification kit includes the necessary parts to provide chad disposal for the typing or nontyping reperforator when mounted in the auxiliary position in an ASR set.
- 1.02 The 170306 modification kit includes the necessary parts to provide chad disposal for the typing or nontyping reperforator when mounted on a Model 28 LAK keyboard. This kit may be used in conjunction with transmitter distributor base (LCXB) for mounting LXD or LBXD transmitter distributors, but is not compatible with the LAXD or LCXD climbing transmitters.
- 1.03 The 164405** modification kit includes the necessary parts to provide a chad container when either or both the keyboard reperforator or auxiliary reperforator are mounted in the ASR unit.
- 1.04 The 195391** modification kit includes the necessary parts to provide a chad container when either or both the keyboard reperforator or auxiliary reperforator are mounted in the ASR unit.
- 1.05 The modification kits can be used with 5 through 8 level reperforators producing fully perforated tape.
- 1.06 The 164272 modification kit consists of:

<u>Qty</u>	<u>Part No.</u>	<u>Description</u>	<u>Qty</u>	<u>Part No.</u>	<u>Description</u>
1	2191	Lockwasher	1	151632	Screw
2	3640	Lockwasher	1	154076	Plate, nut
2	7002	Washer, flat	1	179256	Chute, chad
2	90560	Shim	1	334414	Extension
2	104807	Washer, flat	1	334415	Retainer
2	151152	Screw	1	334584	Guide

SPECIFICATION 50001S

1.07 The 170306 modification kit consists of:

<u>Qty</u>	<u>Part No.</u>	<u>Description</u>	<u>Qty</u>	<u>Part No.</u>	<u>Description</u>
2	3640	Lockwasher	1	195787	Retainer
1	7002	Washer, flat	1	334413	Extension
2	90560	Shim	1	334584	Guide
2	104807	Washer, flat	1	336490	Chute, chad
2	152893	Screw			w/cover

1.08 The 164405** modification kit consists of:

<u>Qty</u>	<u>Part No.</u>	<u>Description</u>	<u>Qty</u>	<u>Part No.</u>	<u>Description</u>
4	2191	Lockwasher	1	164276**	Container, chad
4	3598	Nut	1	164277	Plate, right slide
4	7002	Washer, flat	1	164593	Plate, left slide
4	151631	Screw			

1.09 The 195391** modification kit consists of:

<u>Qty</u>	<u>Part No.</u>	<u>Description</u>	<u>Qty</u>	<u>Part No.</u>	<u>Description</u>
1	1298	Screw	2	151630	Screw
6	2191	Lockwasher	4	151632	Screw
6	3598	Nut	1	195389**	Chute, chad
1	3646	Lockwasher	1	195390**	Bin, chad
1	5599	Nut	1	195404**	Shelf, chad bin
10	7002	Washer, flat			

1.10 The double asterisks (**) represent a two-letter suffix which indicates the paint finish.

2. INSTALLATION

Modification Kit 164272 (Figure 1)

2.01 Mount 179256 chad chute to punch block using 151152 screws, 3640 lockwashers, 90560 shims, and 104807 flat washers.

(a) If the reperfocator punch block has a flat mounting surface (epoxy design) the 90560 shims mount under the 104807 flat washers.

(b) If there is an offset (0.012 inch) on the reperfocator punch block mounting surface, the 90560 shims mount between the chad chute and the punch block.

- 2.02 Mount reperforator to its base plate by adjusting the reperforator to its proper belt tension.
- 2.03 Mount the 334584 wire guide to the perforator base using the 151632 screw, 2191 lockwasher, two 7002 flat washers, and 154076 nut plate. Insert the 334414 extension through the 334584 wire guide and over the extension of the 179256 chad chute. Mount the 334415 retainer using the right mounting screw of the 179256 chad chute.

Note: Care must be taken when mounting the 334414 extension to use its natural curvature to prevent flats or kinks.

- 2.04 Mount this assembly to the reperforator base plate.
- 2.05 When making field conversions of chadless to fully perforated tape equipment, a body hole is required in the LAAC cabinet body assembly. The rectangular cut-out enables the chad chutes to protrude into the chad container in the bottom of the cabinet.
- (1) If neither the 4.172 dia body holes or rectangular cut-out are in the cabinet they must be added as shown in Figure 4.
 - (2) Cut a rectangular hole in the fiber glass insulator in the bottom of the cabinet. The hole should be just above the chute cut-out in the cabinet floor.
 - (3) See instructions for the 164405 modification kit which indicates the proper hardware for mounting in these body holes.

Modification Kit 170306 (Figure 2)

Note: The installation of this kit is to be made prior to keyboard installation.

- 2.06 Before the keyboard is installed in the cabinet, mount the 336490 chad chute to the keyboard reperforator punch block using the two 152893 screws, 3640 lockwashers, 104807 flat washers, and 90560 shims furnished with the kit. If the punch on the reperforator has a flat mounting surface (epoxy design) the shim is mounted under the flat washer. If there is an offset (0.012 inch) on the mounting surface then the shim is placed between the chad chute and punch block. Mount the keyboard into the cabinet.

SPECIFICATION 50001S

2.07 Mount the 334584 wire guide to the keyboard base using the existing screw and lockwasher located next to the reperforator mounting foot and the 7002 flat washer furnished with the modification kit. Insert the 334413 extension through the wire guide and over the extension of the 336490 chad chute. Mount the 195787 retainer using the left mounting screw of the 336490 chad chute.

Note: Care must be taken when mounting the 334413 extension to use its natural curvature to prevent flats or kinks.

Modification Kit 164405** (Figures 3 and 4)

2.08 Cut a rectangular hole in the fiber glass insulation above the chad chute cut-out in the cabinet floor.

Note: When making a field conversion from chadless to fully perforated tape equipment, a rectangular cut-out is required in the upper shelf of those LAAC cabinets not already provided with one. The cut-out allows the 164275 and 164278 chad chutes to protrude into the 164276** chad container mounted to the 154455 shelf brace. See Figure 4 for location and size of the rectangular cut-out and the four mounting holes for the chad container.

2.09 Mount the 164277 right slide plate and 164593 left slide plate to the underside of the ASR (LAAC) cabinet on the shelf brace below the chad chute cut-out. Use the 151631 screws, 2191 lockwasher, 7002 flat washers, and 3598 nuts to secure the plates.

Modification Kit 195391** (Figures 5, 6, and 7)

2.10 Cut a rectangular hole in the fiber glass or felt pad insulation above the chad chute cut-out in the cabinet upper shelf.

Note: When making a field conversion from chadless to fully perforated tape equipment, a rectangular cut-out is required in the upper shelf on those LAAC cabinets not already provided with one. The cut-out allows the reperforator chad chutes to protrude into the 195389** chad chute mounted to the 158670 cabinet door panel. See Figure 5 for location and size of the rectangular cut-out.

2.11 Remove the 158670 lower right door panel from the cabinet by means of the removable 158672 shaft and 153037 spring. Cut a rectangular hole in the 158670 panel and drill two 0.147 diameter and four 0.203 diameter holes as illustrated in Figure 6. Remove rough edges and burrs from the rectangular cut-outs and drilled holes.

- 2.12 Mount the 195404** chad bin shelf to the front of the 158670 panel door by means of the four 151632 screws, 2191 lockwashers, 3598 nuts, and eight 7002 flat washers as illustrated in Figure 7. Align the shelf so that it is flush or slightly underflush with the left edge of the 158670 door panel.
- 2.13 Mount the 195389** chad chute to the rear of the 158670 door panel by means of the two 151630 screws, 7002 flat washers, 2191 lockwashers, and 3598 nuts as illustrated in Figure 7.
- 2.14 Replace the 158670 door panel by means of the 158672 shaft and 153037 spring.
- 2.15 Mount the 1298 screw in the 195390** chad bin by means of the 3646 lockwasher and 5599 nut. The screw head should be located on the outside of the chad bin.
- 2.16 Slide the 195390** chad bin on the 195404** shelf until the chad bin screw engages in the opening provided in the 195404** shelf.

3. ADJUSTMENTS

- 3.01 By means of elongated slots, adjust chad chutes in 164272 and 170306 modification kits for equal clearance in all directions with adjacent units. Tighten mounting screws.
- 3.02 Modification kit 164405** — Using the slack in mounting screw body holes, position left and right slide plates to allow cabinet door to close without interfering with chad container.

*

*

*

500015

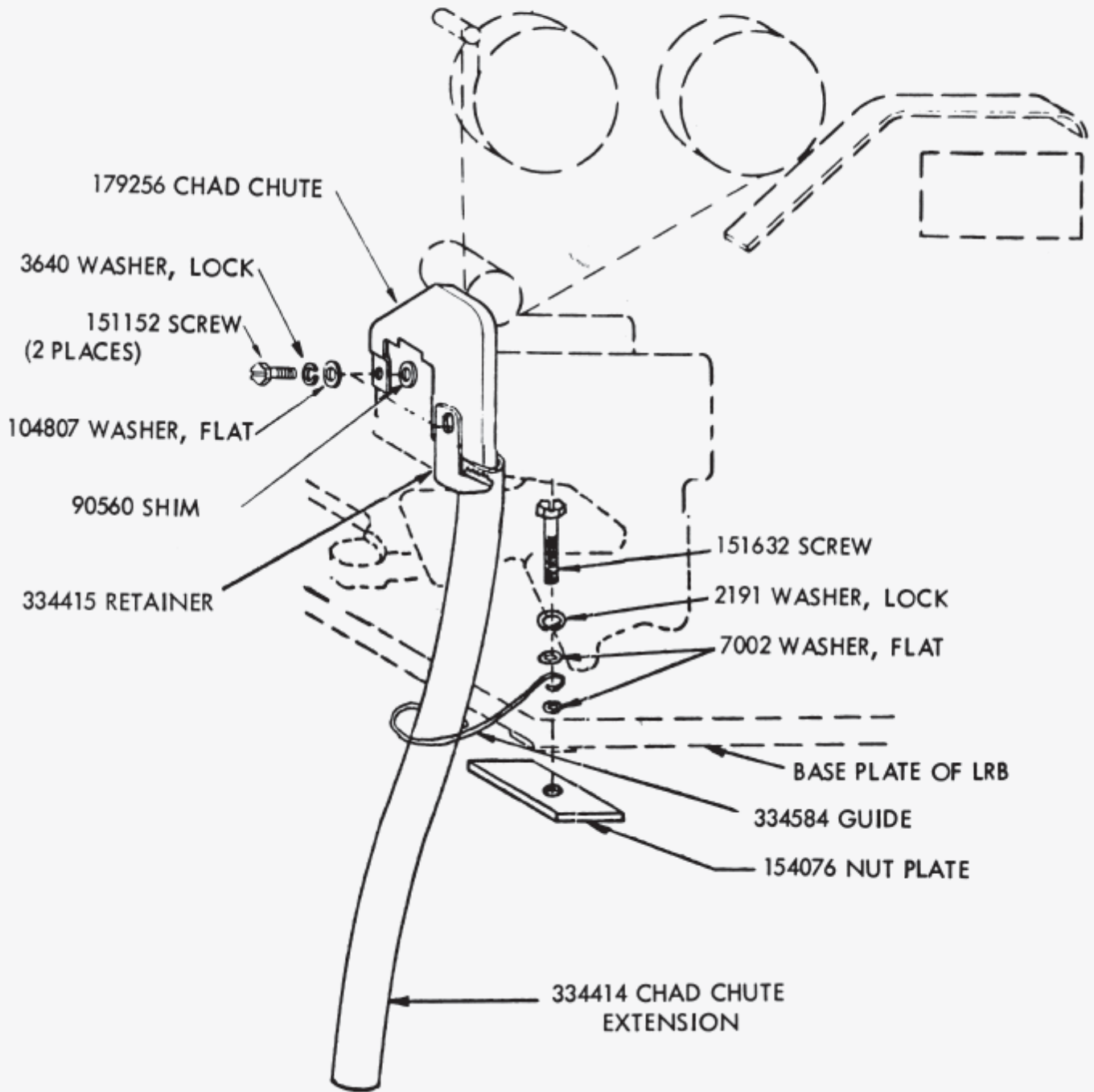
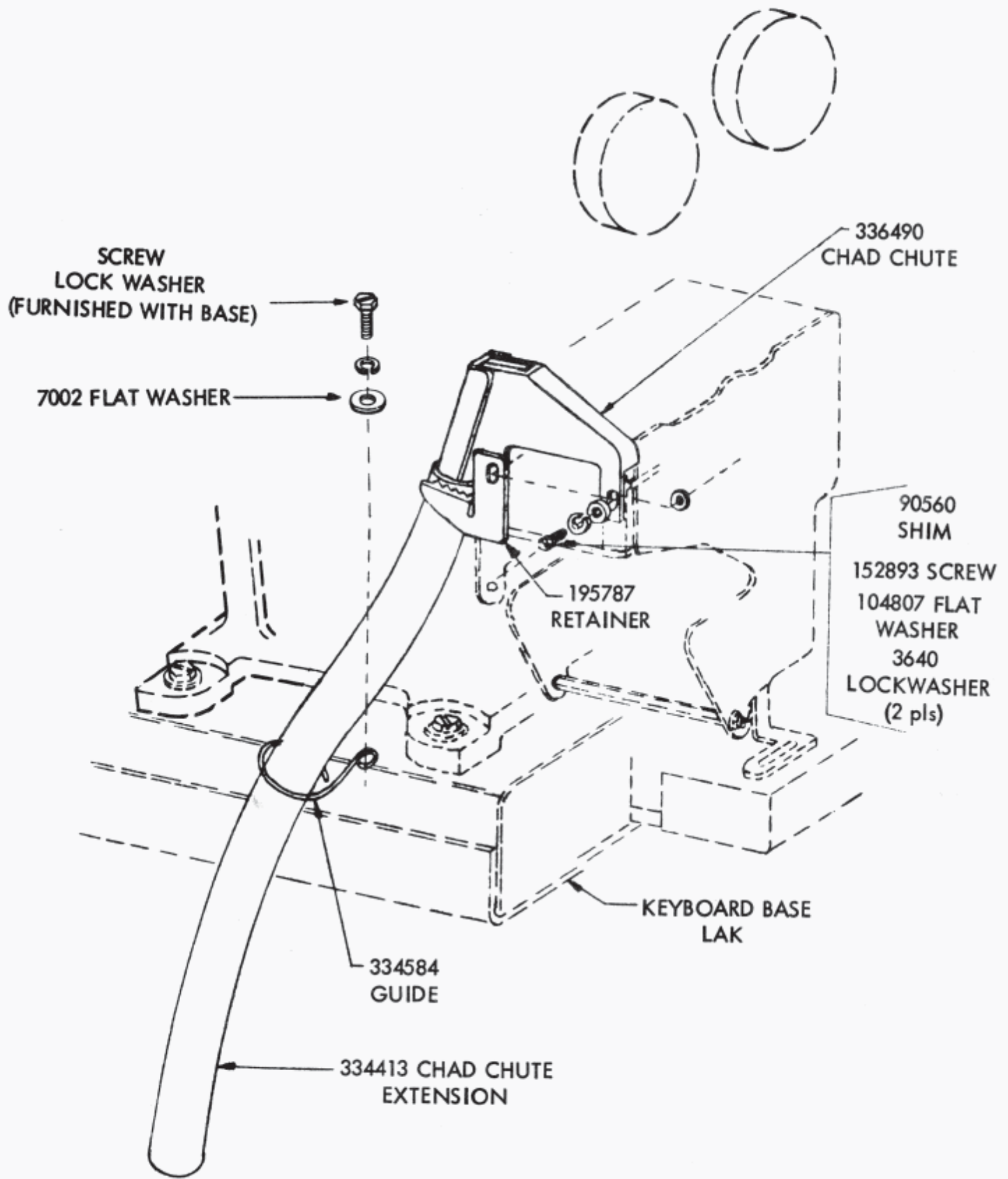

FIGURE 1. PERTAINS TO 164272 MODIFICATION KIT

500015



50001S

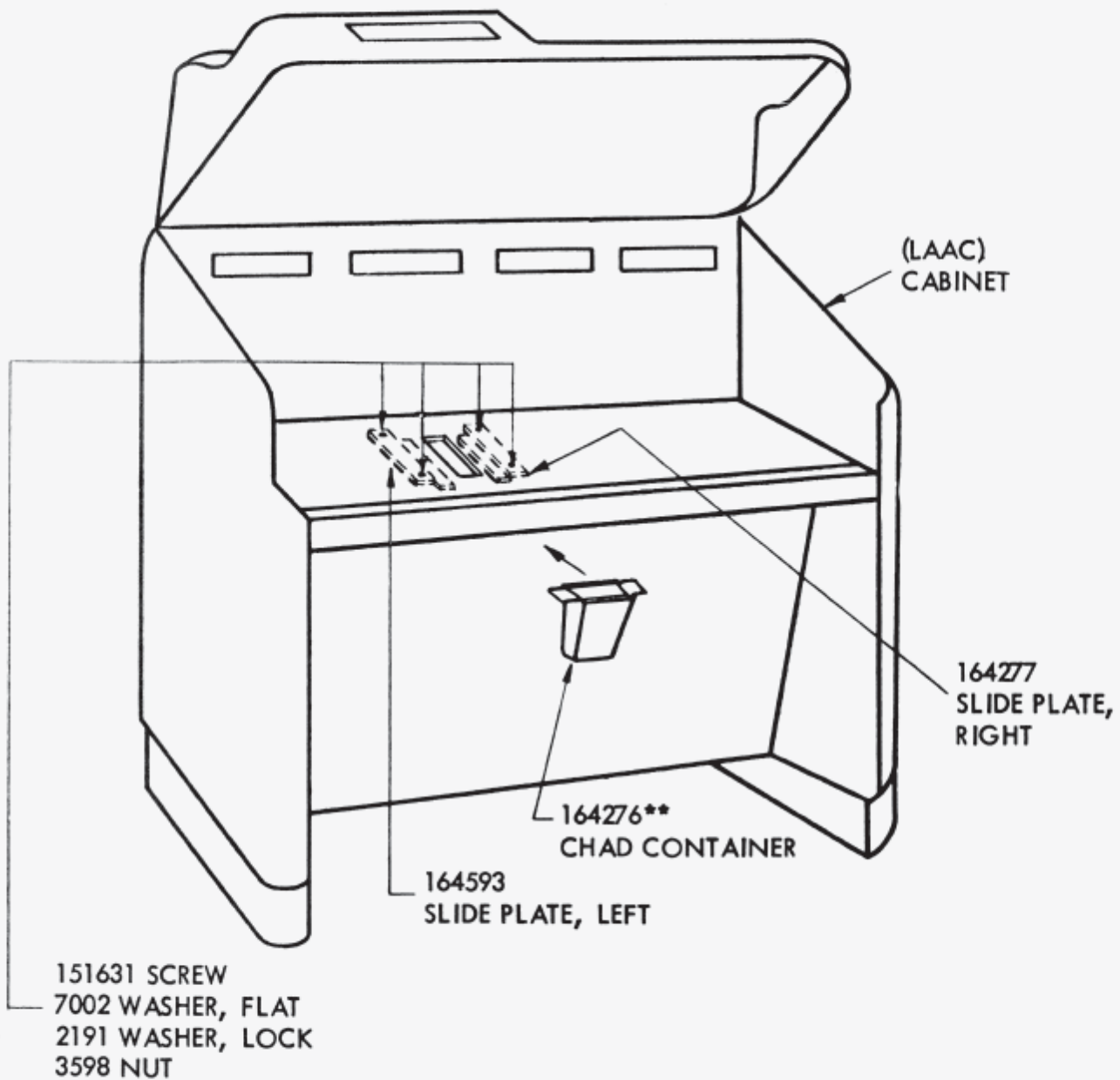
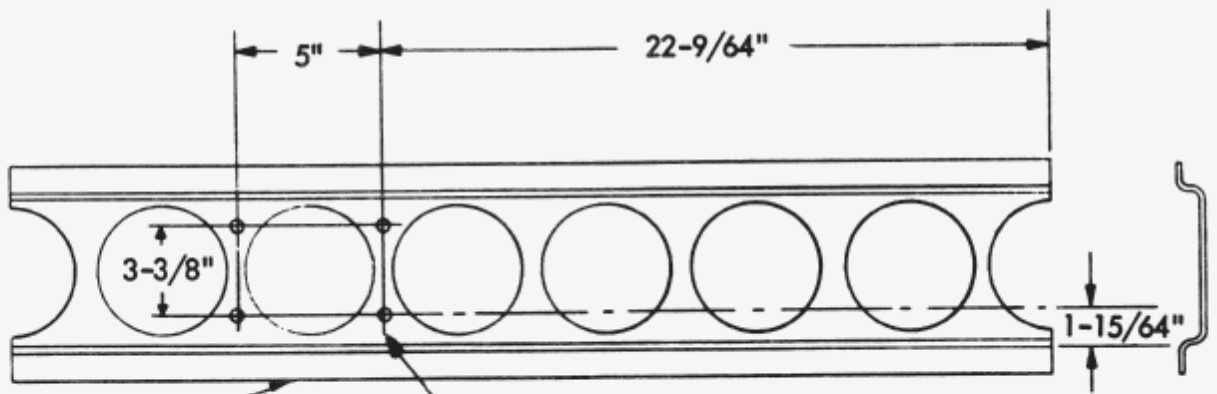
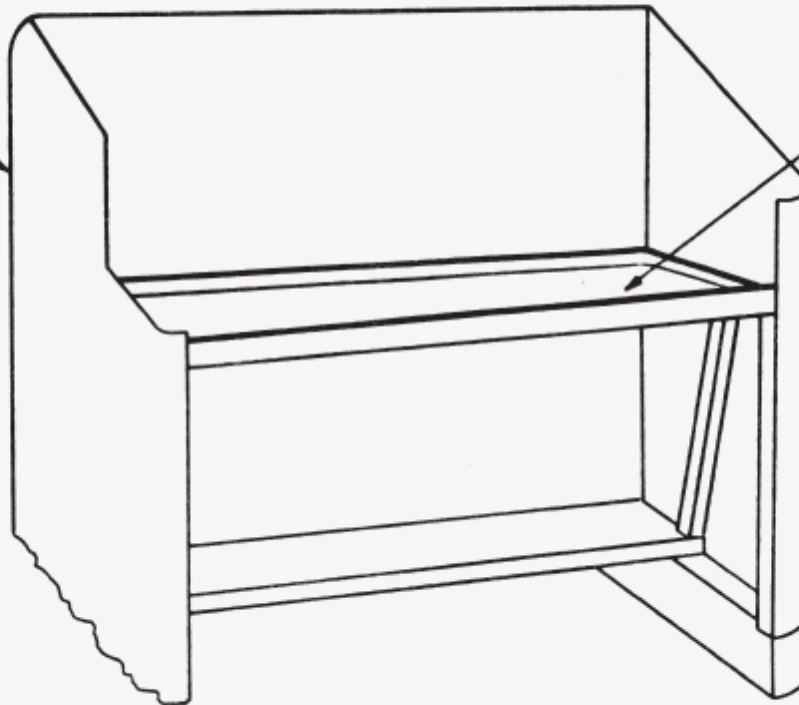

FIGURE 3. PERTAINS TO 164405** MODIFICATION KIT

50001S

LAAC CABINET

154460 UPPER SHELF



154455 SHELF BRACE

11/64" DIA. (4 PLACES)

154460 UPPER SHELF

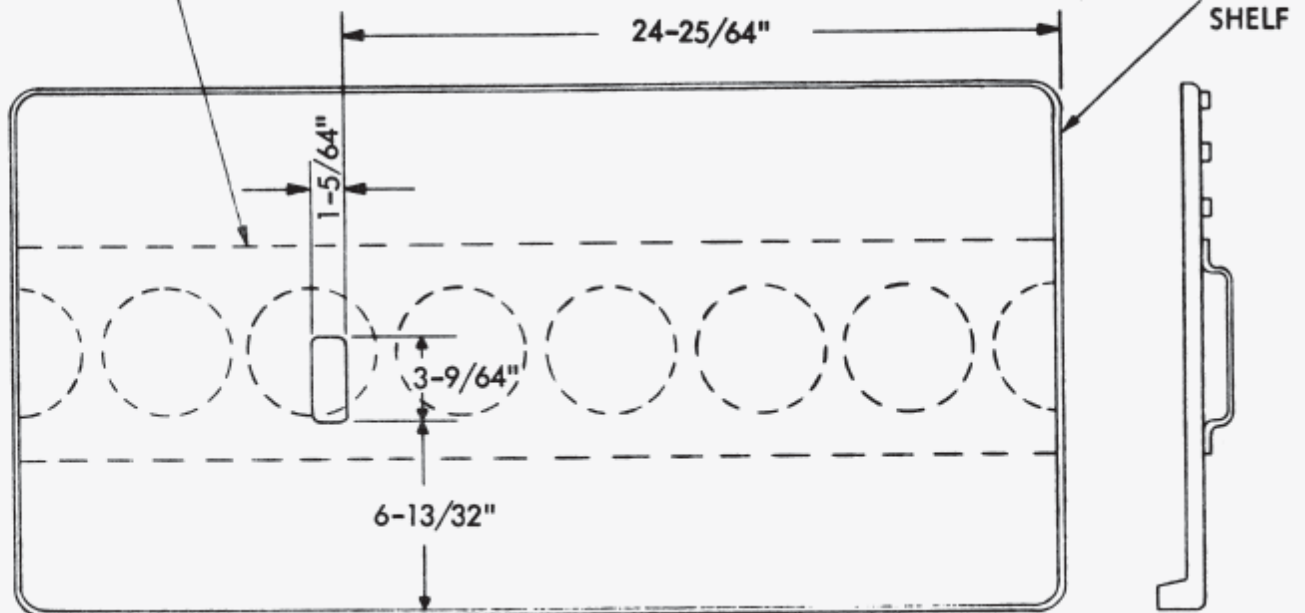

50001S

LAAC
CABINET

154460 UPPER
SHELF

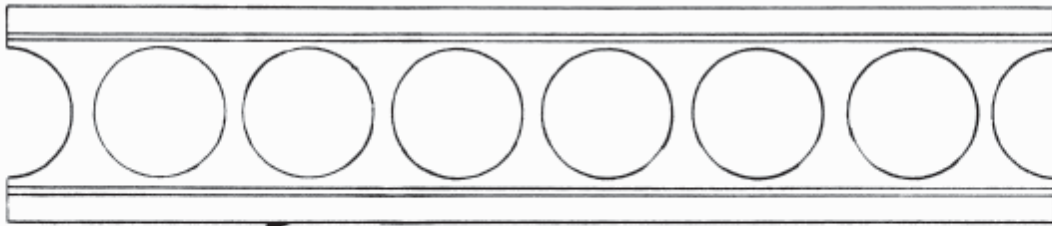
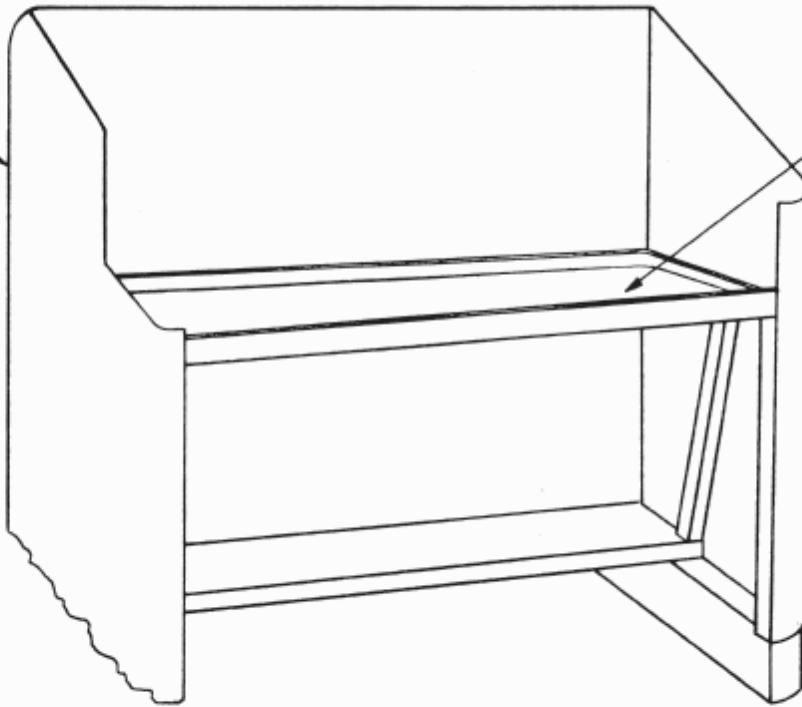

154455 SHELF
BRACE

154460 UPPER
SHELF

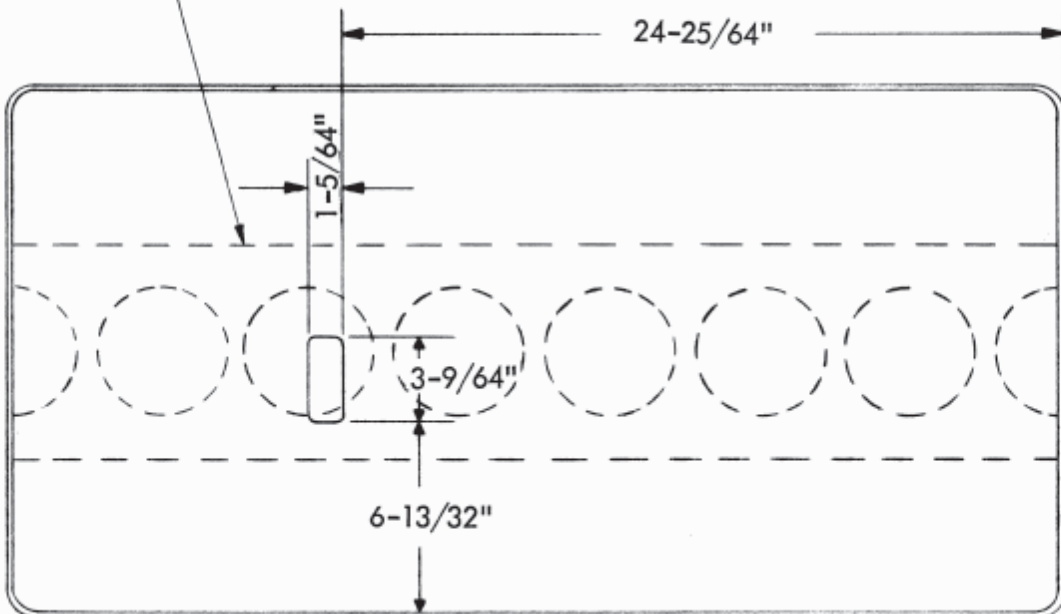
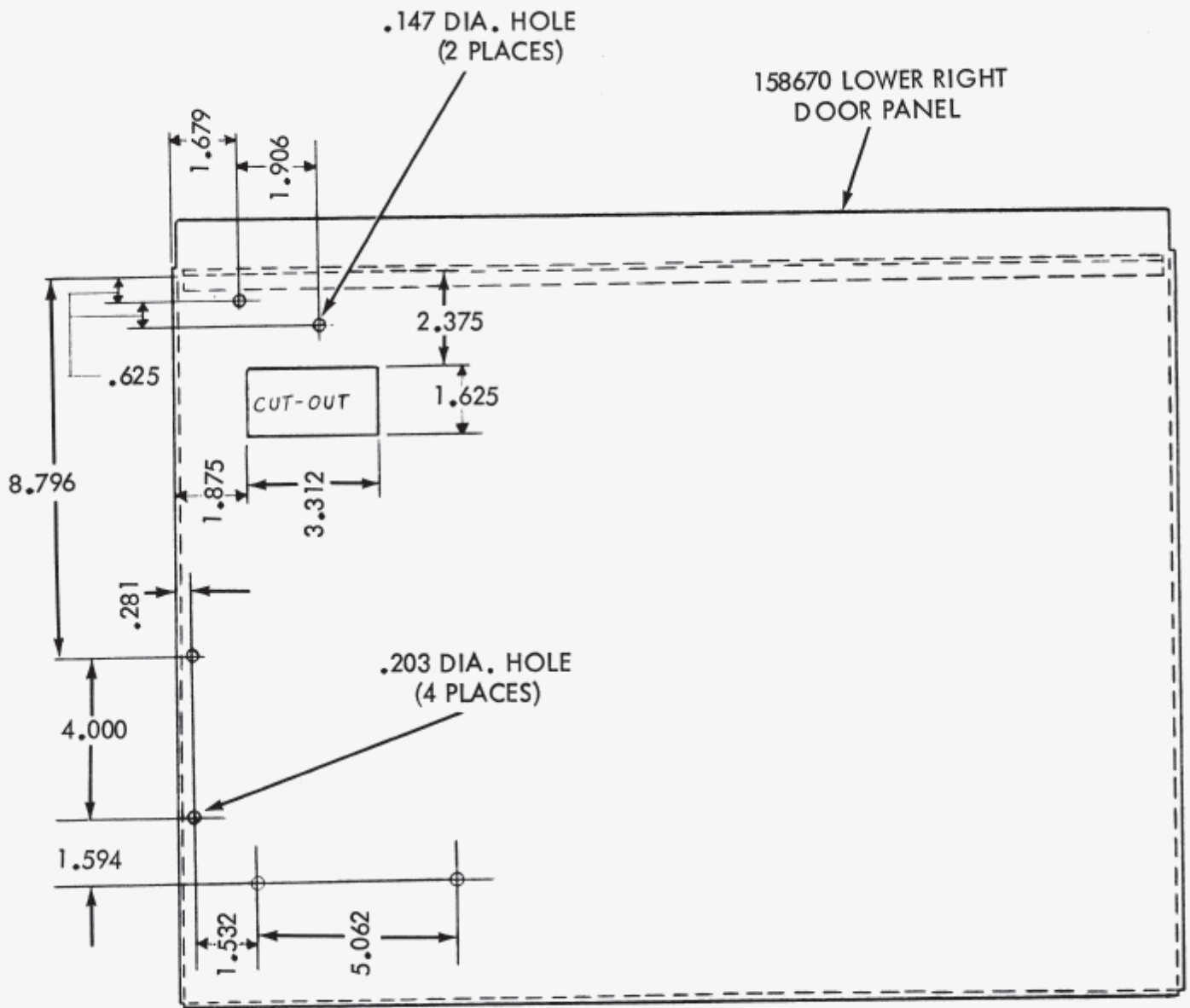

FIGURE 5 PERTAINS TO FIELD CONVERSION OF 10501S MODIFICATION USE

50001S



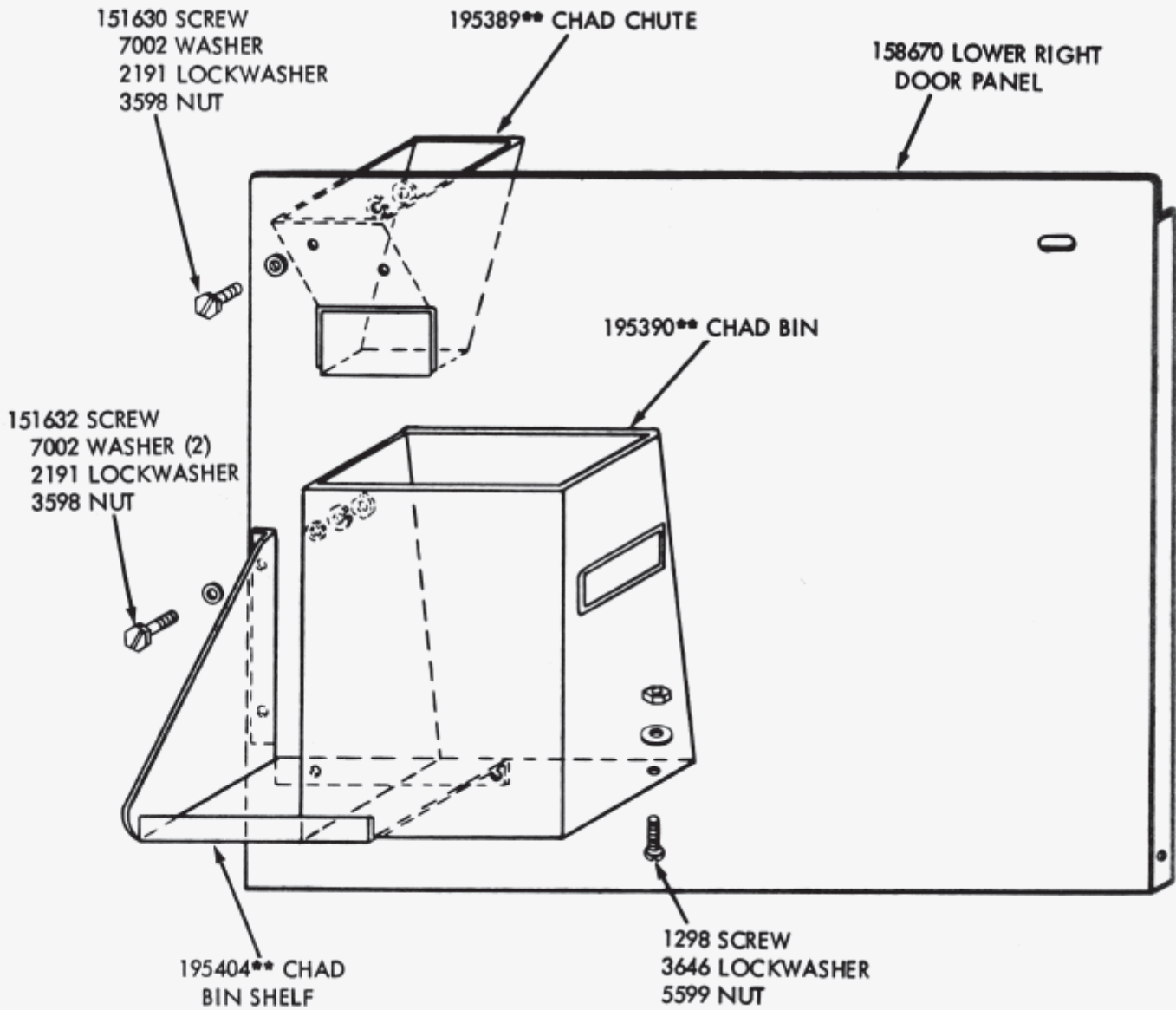

FIGURE 7. 195391** MODIFICATION KIT MOUNTING ARRANGEMENT