

TRANSMITTER DISTRIBUTOR

FOR INSTRUCTIONAL PURPOSES ONLY

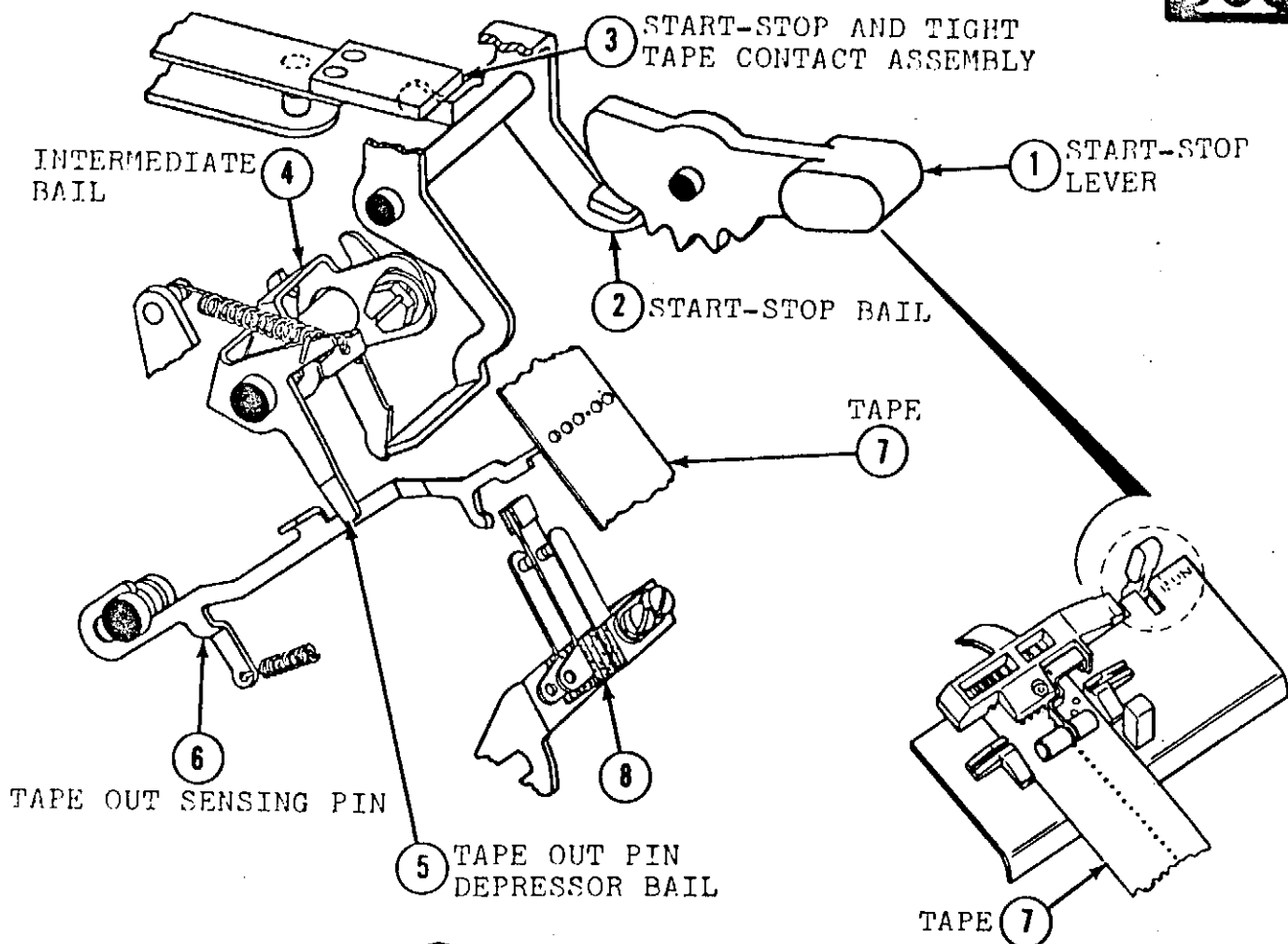

As START-STOP LEVER (1) is moved to the Run Position it pivots clockwise releasing START-STOP BAIL (2) to rotate counterclockwise allowing START-STOP AND TIGHT TAPE CONTACT ASSEMBLY (3) to close. As START-STOP BAIL (2) moves counterclockwise it allows spring loaded INTERMEDIATE BAIL (4) to move counterclockwise rotating TAPE OUT PIN DEPRESSOR BAIL (5) counterclockwise. As TAPE OUT PIN DEPRESSOR BAIL (5) rotates it releases spring loaded TAPE OUT SENSING PIN (6) to move upward. If TAPE (7) is in unit, TAPE (7) will prevent TAPE OUT SENSING PIN (6) from moving up far enough to open TAPE OUT CONTACT ASSEMBLY (8). If no TAPE (7) is in unit, TAPE OUT SENSING PIN (6) will move up opening TAPE OUT CONTACT ASSEMBLY (8).

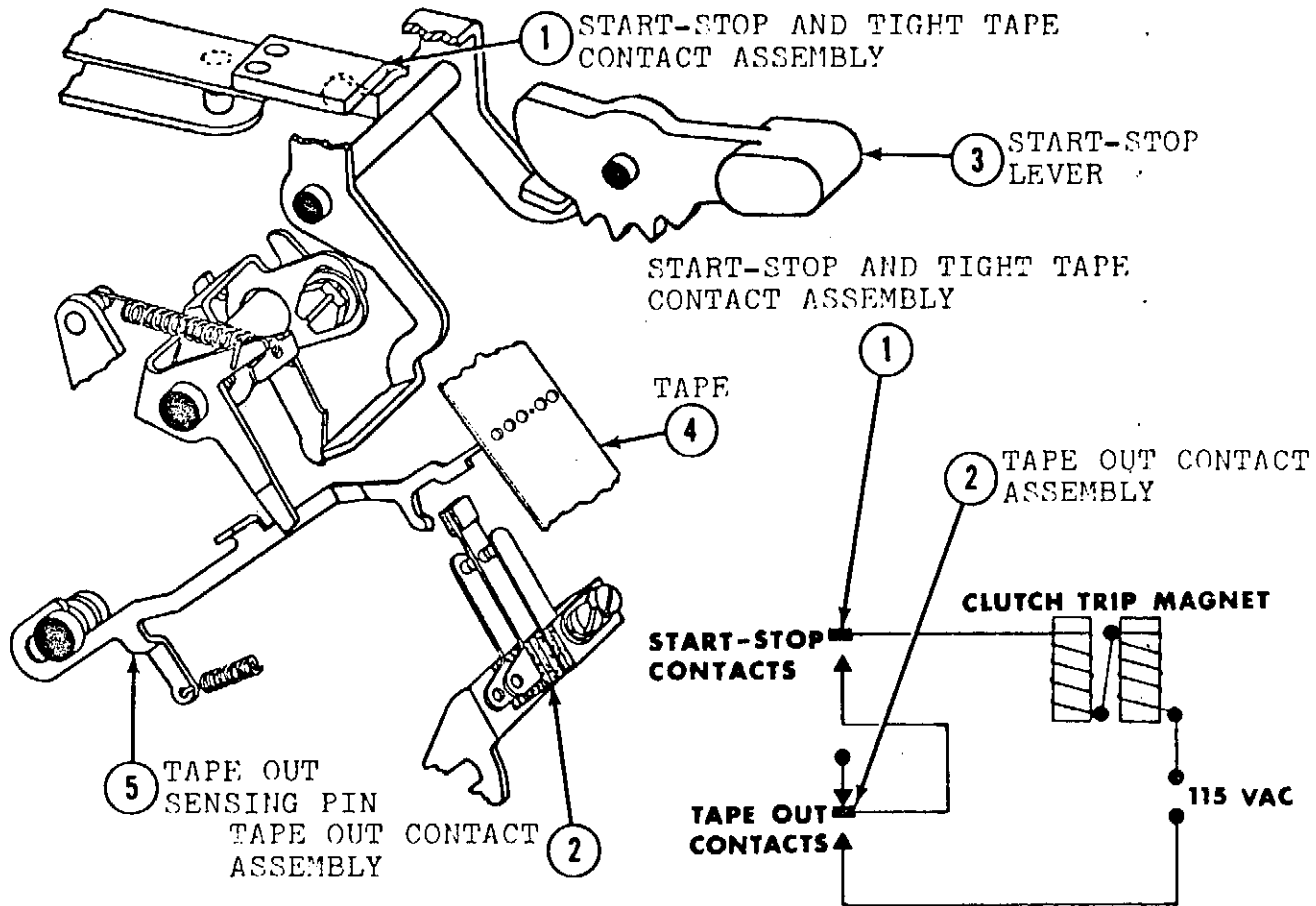

To operate the Transmitter Distributor both the START-STOP AND TIGHT TAPE CONTACT ASSEMBLY (1) and TAPE OUT CONTACT ASSEMBLY (2) must be closed since they are in series with each other. For both contacts to be closed the START-STOP LEVER (3) must be in the Run Position and TAPE (4) must be in unit holding TAPE OUT SENSING PIN (5) downward preventing it from moving up opening TAPE OUT CONTACT ASSEMBLY (2). If START-STOP LEVER (3) is moved to Stop Position the START-STOP AND TIGHT TAPE CONTACT ASSEMBLY (1) opens. If START-STOP LEVER (3) is in Run Position, but no TAPE (4) is in unit, TAPE OUT SENSING PIN (5) moves up opening TAPE OUT CONTACT ASSEMBLY (2). In Run Position after TAPE (4) has run completely through the unit, it will move away from TAPE OUT SENSING PIN (5) therefore stopping the unit.

FOR INSTRUCTIONAL PURPOSES ONLY

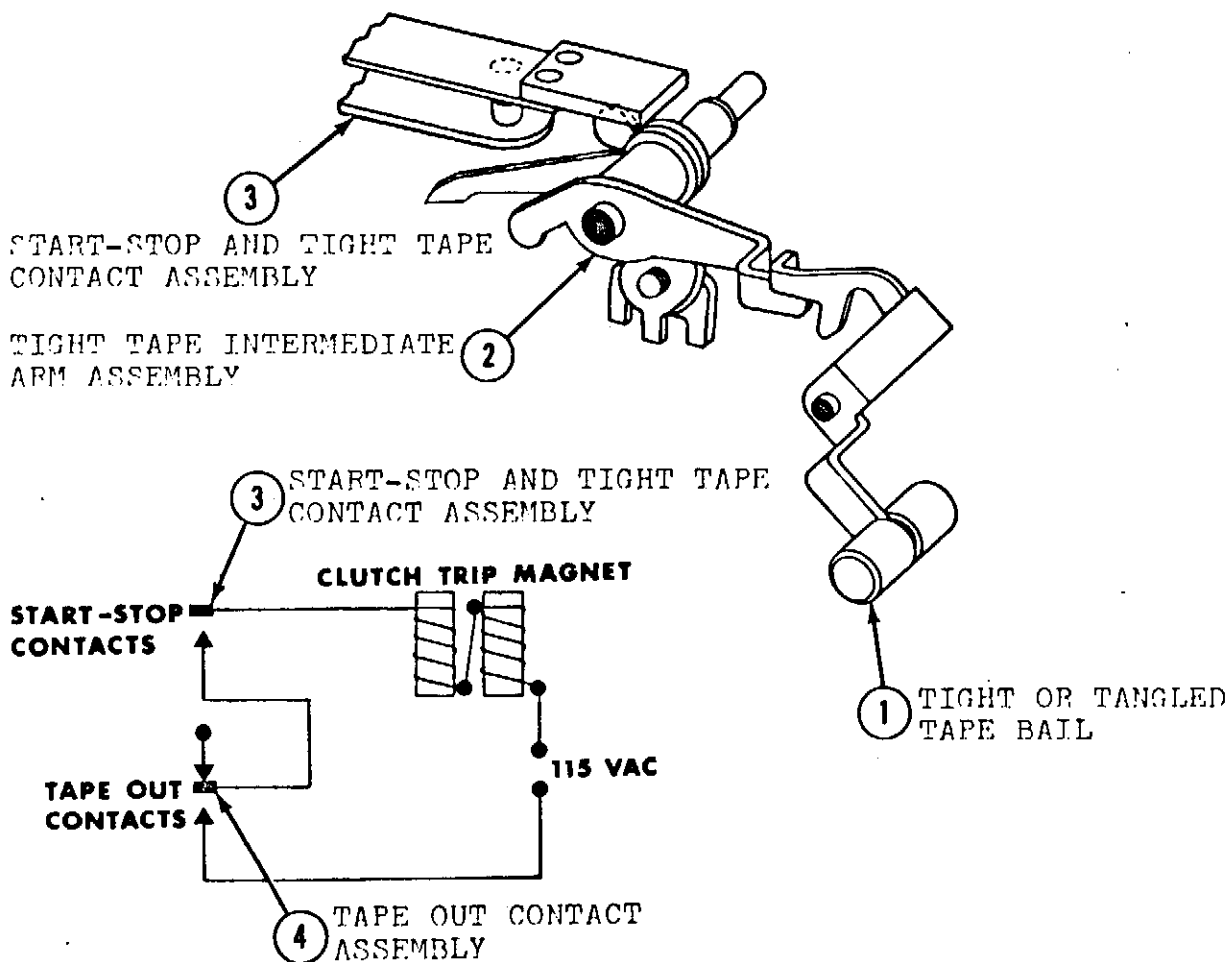

If Tape becomes tight or tangled the TIGHT OR TANGLED TAPE BAIL (1) is rotated counterclockwise driving TIGHT TAPE INTERMEDIATE ARM ASSEMBLY (2) clockwise opening START-STOP AND TIGHT TAPE CONTACT ASSEMBLY (3). Since both the START-STOP AND TIGHT TAPE CONTACT ASSEMBLY (3) and TAPE OUT CONTACT ASSEMBLY (4) must be closed for unit to run, it will stop.

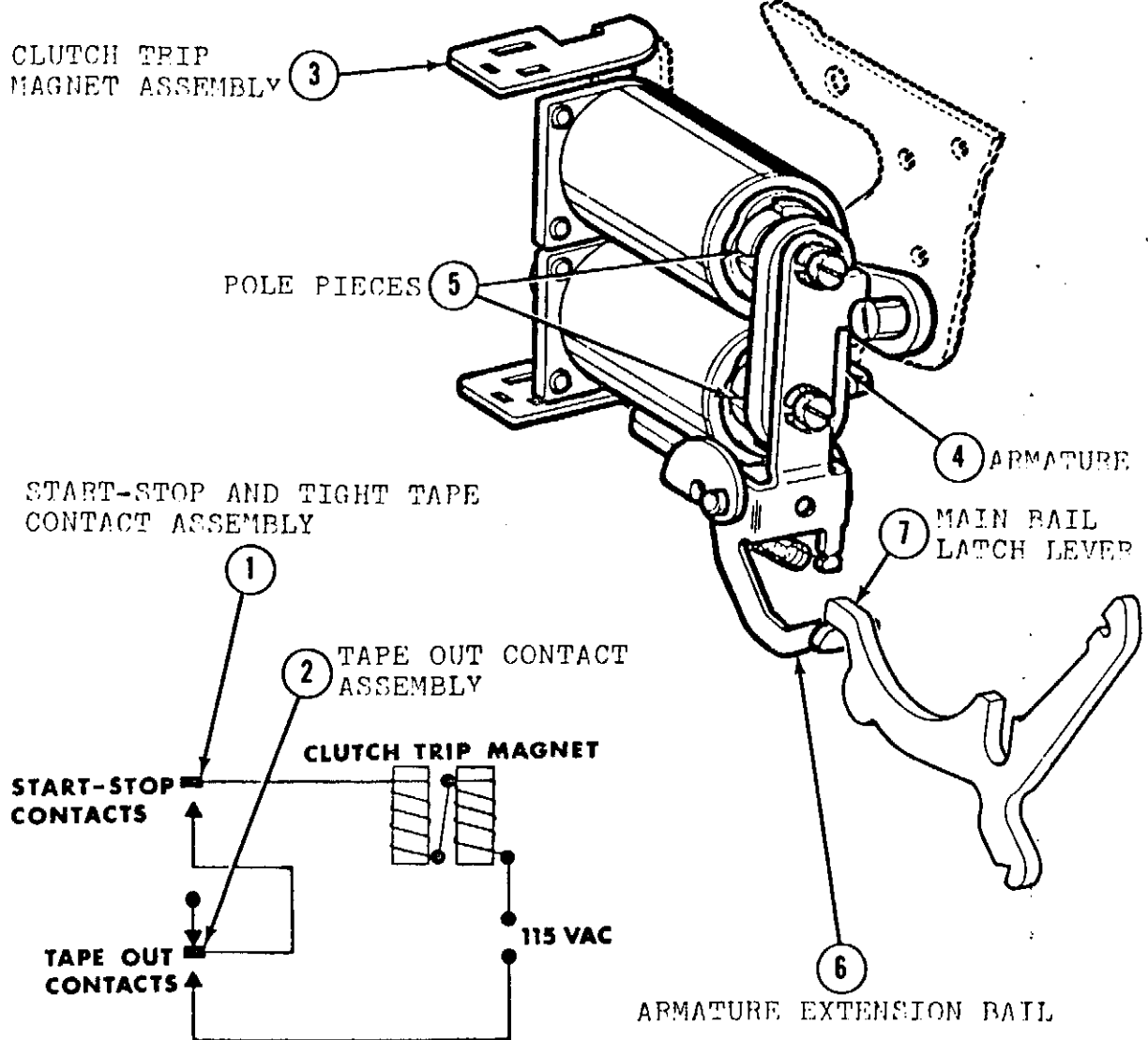

If both the START-STOP AND TIGHT TAPE CONTACT ASSEMBLY (1) and TAPE OUT CONTACT ASSEMBLY (2) are closed it will allow CLUTCH TRIP MAGNET ASSEMBLY (3) to become energized. As ARMATURE (4) moves against POLE PIECES (5) the ARMATURE EXTENSION BAIL (6) moves upward rotating MAIN BAIL LATCH LEVER (7) clockwise.

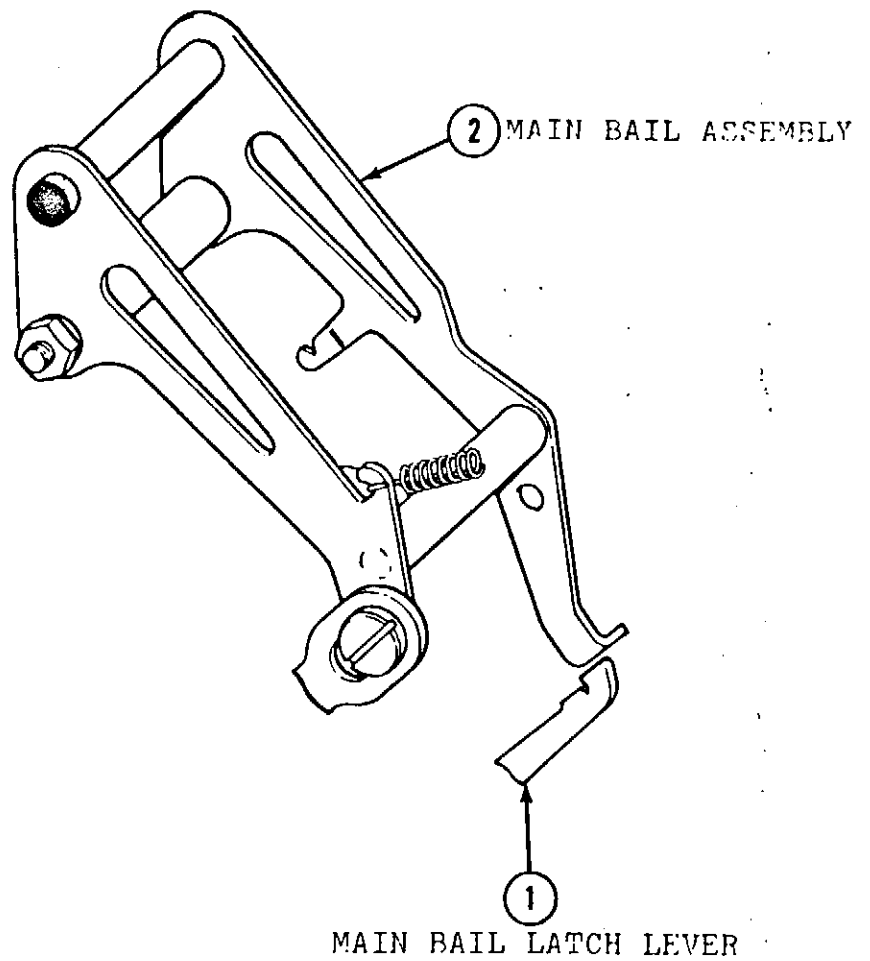

When MAIN BAIL LATCH LEVER ① is rotated clockwise it releases MAIN BAIL ASSEMBLY ② to move upward in a counter-clockwise direction.

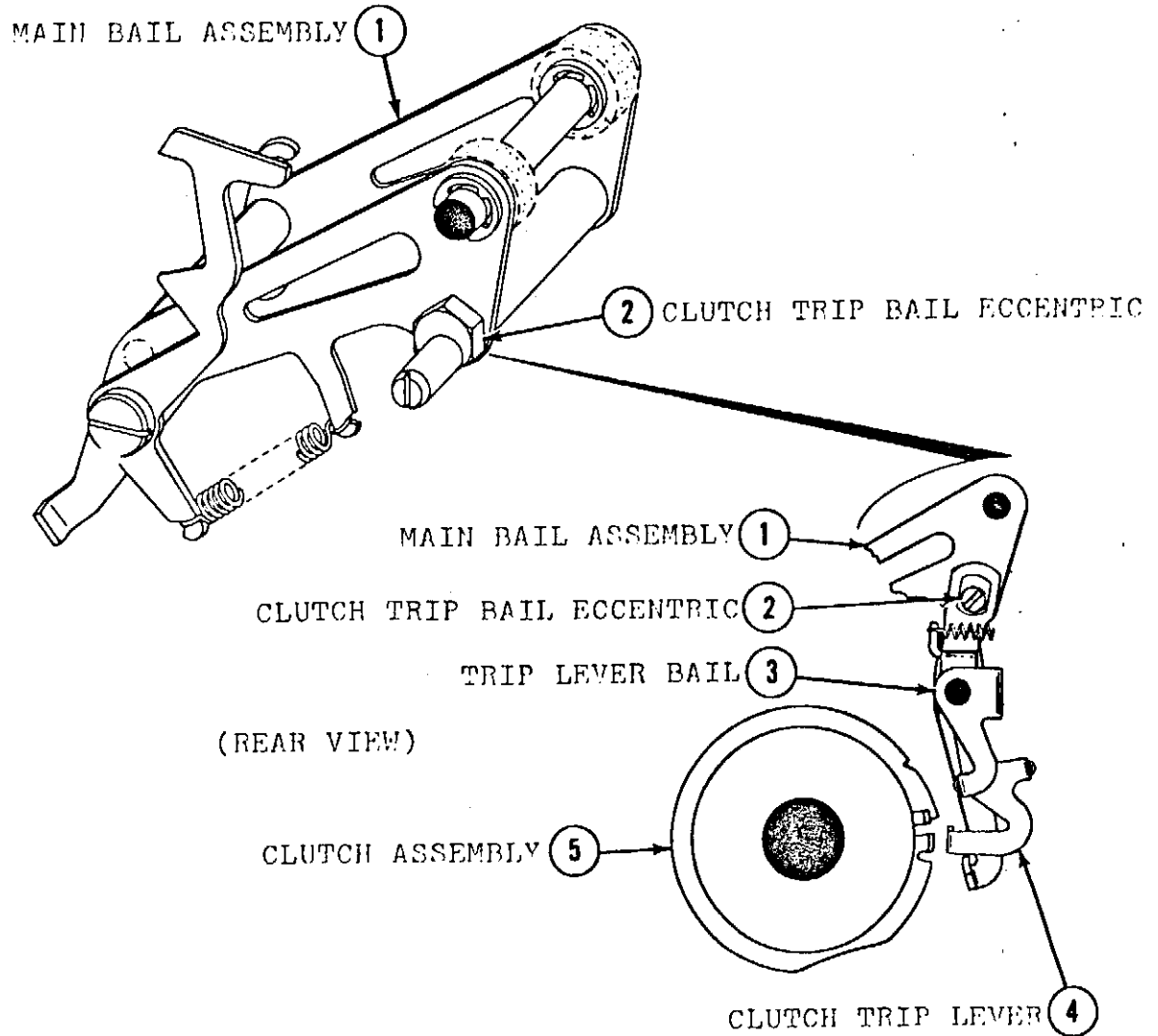

As MAIN BAIL ASSEMBLY (1) moves up in a clockwise direction (As viewed from rear of unit) CLUTCH TRIP BAIL ECCENTRIC (2) moves to the left rotating TRIP LEVER BAIL (3) counterclockwise. As TRIP LEVER BAIL (3) rotates counterclockwise it rotates CLUTCH TRIP LEVER (4) counterclockwise allowing CLUTCH ASSEMBLY (5) to become engaged.

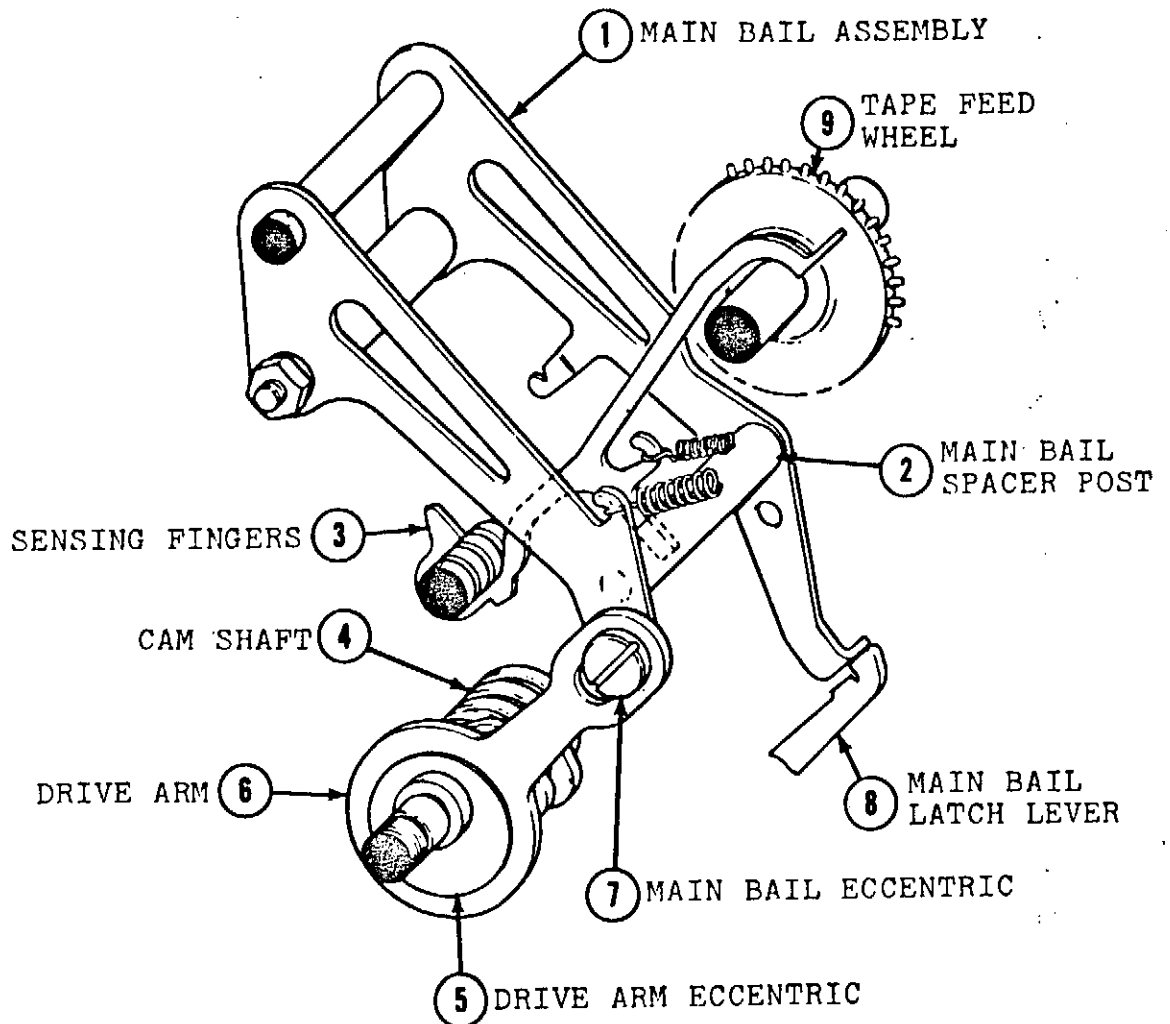

When MAIN BAIL ASSEMBLY (1) moves upward its MAIN BAIL SPACER POST (2) releases all spring loaded SENSING FINGERS (3) to move upward to sense holes in Tape. As CAM SHAFT (4) and DRIVE ARM ECCENTRIC (5) rotate clockwise it causes DRIVE ARM (6) to pull downward on MAIN BAIL ECCENTRIC (7) until MAIN BAIL LATCH LEVER (8) latches over MAIN BAIL ASSEMBLY (1). As reset action is taking place, the MAIN BAIL SPACER POST (2) which is part of MAIN BAIL ASSEMBLY (1) will withdraw SENSING FINGERS (3) from Tape and rotate TAPE FEED WHEEL (9).



FEED WHEEL RATCHET

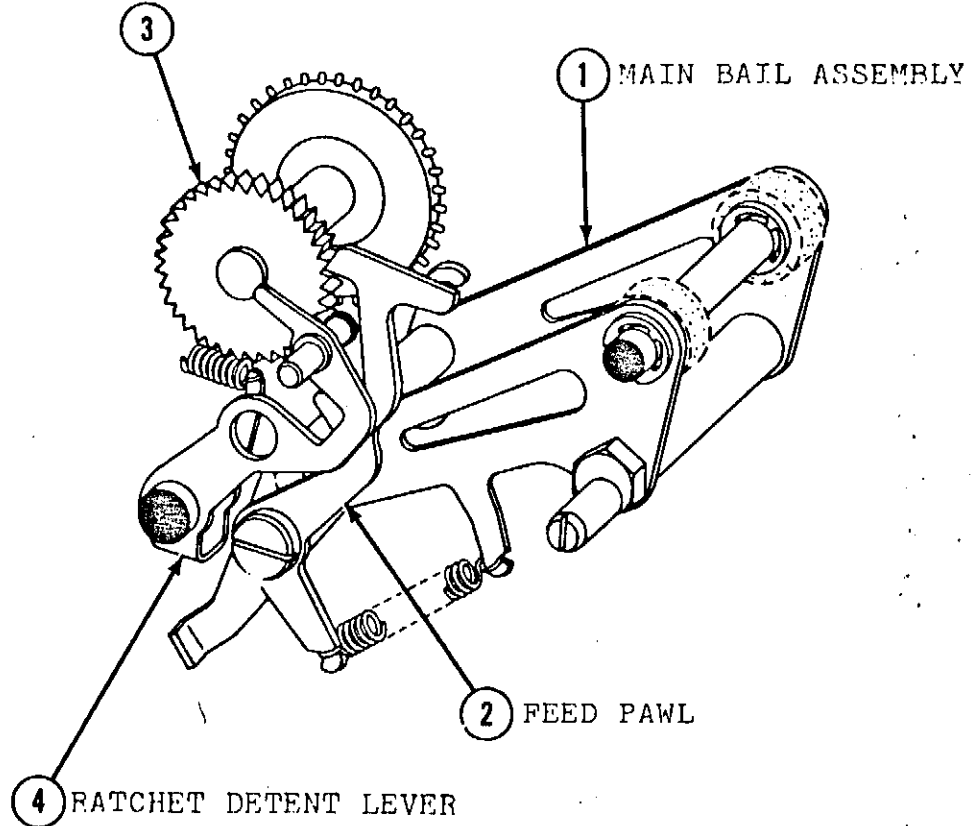

(REAR VIEW)

As MAIN BAIL ASSEMBLY (1) is released and moves upward the FEED PAWL (2) which is attached to MAIN BAIL ASSEMBLY (1) will move upward engaging a new tooth on FEED WHEEL RATCHET (3) while RATCHET DETENT LEVER (4) holds FEED WHEEL RATCHET (3) in place. As MAIN BAIL ASSEMBLY (1) is pulled downward the FEED PAWL (2) will rotate the FEED WHEEL RATCHET (3) one tooth overriding the RATCHET DETENT LEVER (4) which will seek a new position after feeding is completed.

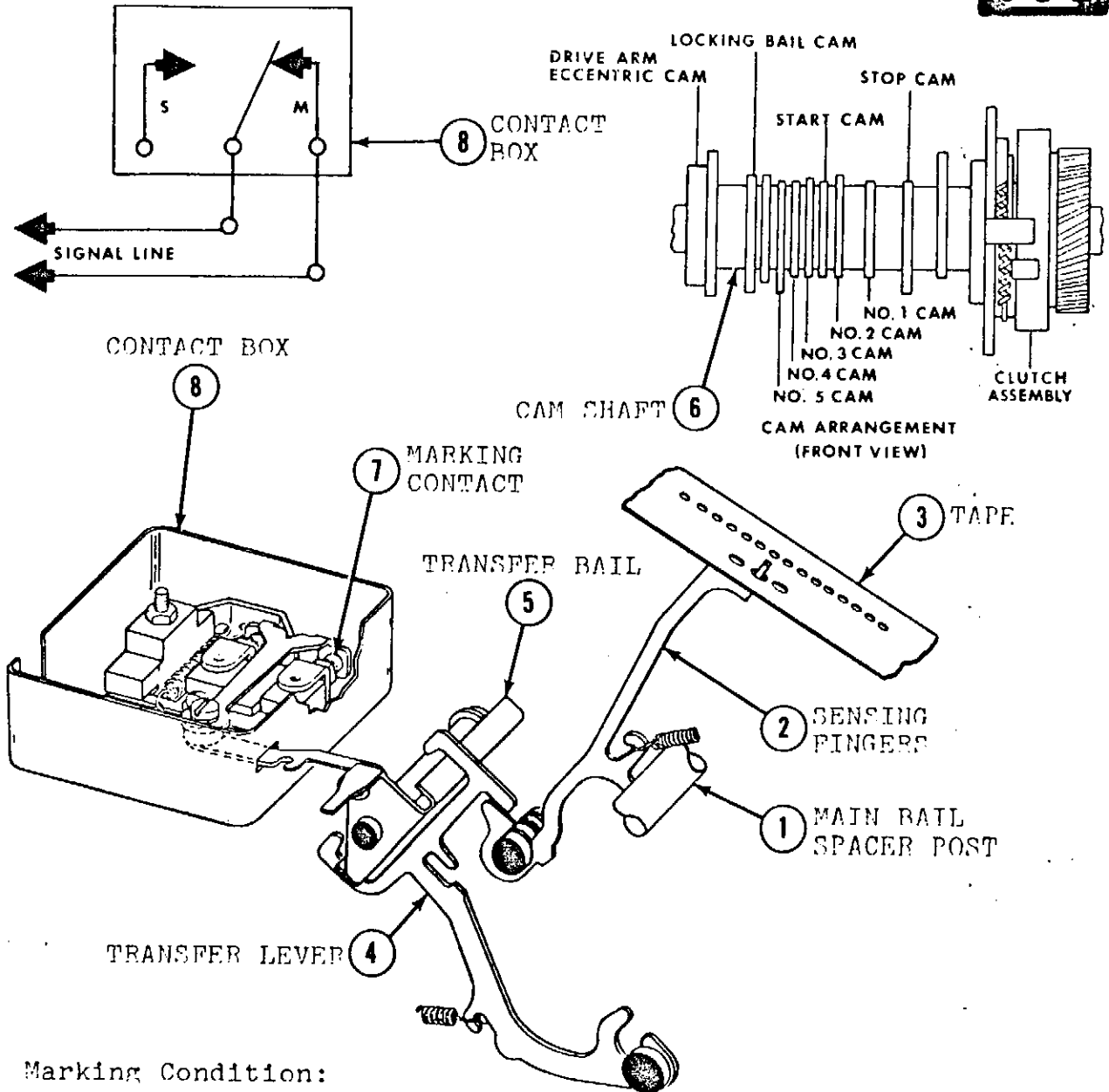

Marking Condition:

As MAIN BAIL SPACER POST (1) moves upward it releases all spring loaded SENSING FINGERS (2) to move upward to sense holes in TAPE (3). If SENSING FINGER (2) moves through hole in TAPE (3) it will pull TRANSFER LEVER (4) to right placing left side of TRANSFER LEVER (4) over left side of TRANSFER BAIL (5). As CAM SHAFT (6) rotates a Cam will drive TRANSFER LEVER (4) downward pulling TRANSFER BAIL (5) counterclockwise closing MARKING CONTACT (7) through linkare to CONTACT BOX (8).

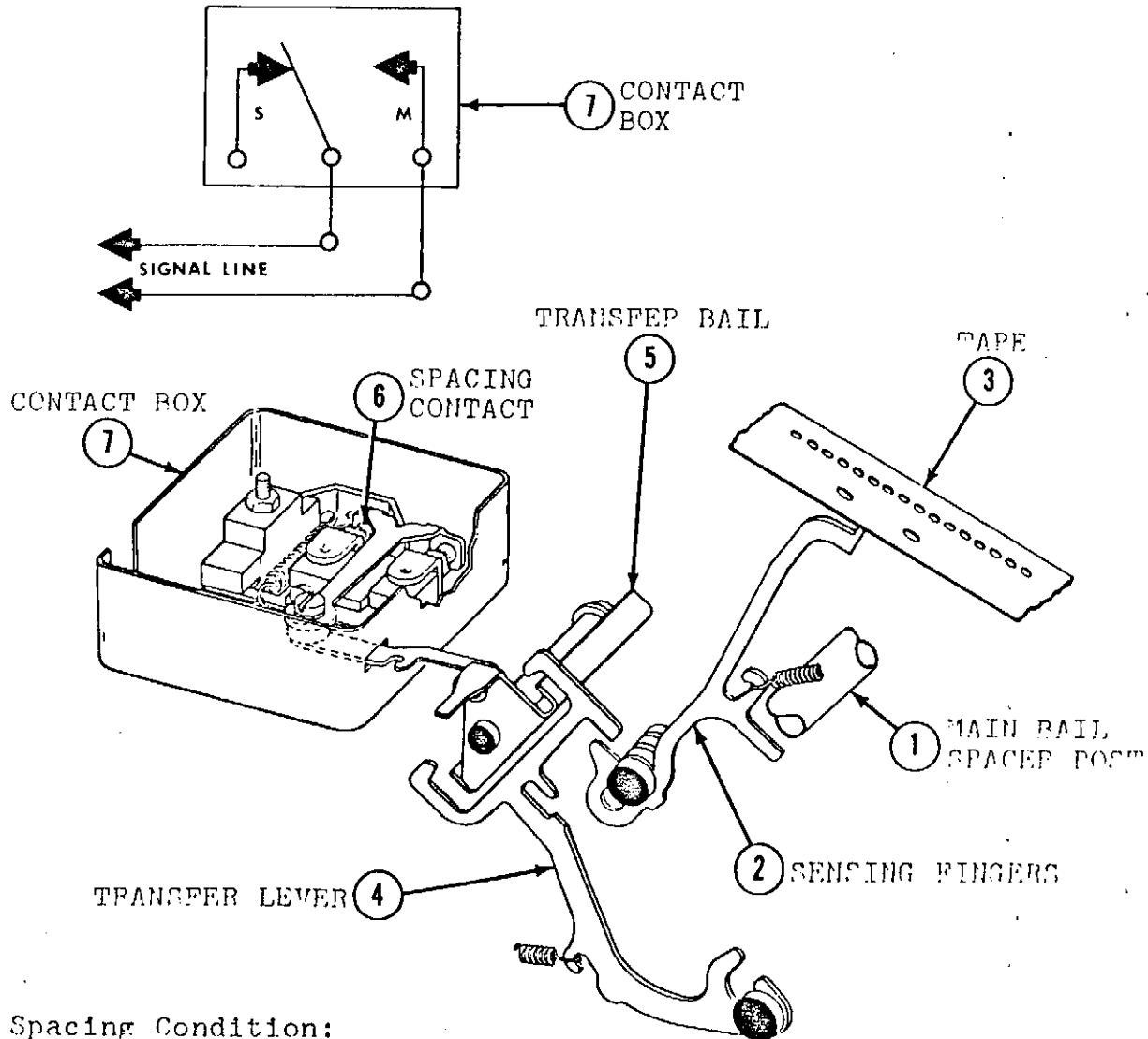

Spacing Condition:

As MAIN BAIL SPACER POST (1) moves upward it releases all spring loaded SENSING FINGERS (2) to move upward to sense holes in TAPE (3). If there is no hole available in TAPE (3), SENSING FINGER (2) will not contact TRANSFER LEVER (4). Right side of TRANSFER LEVER (4) will remain over right side of TRANSFER BAIL (5). As Cam Shaft rotates a Cam will drive TRANSFER LEVER (4) downward pulling TRANSFER BAIL (5) clockwise closing SPACING CONTACT (6) through linkage to CONTACT BOX (7).

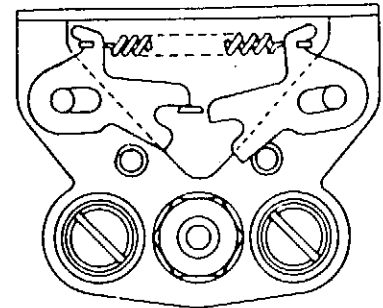
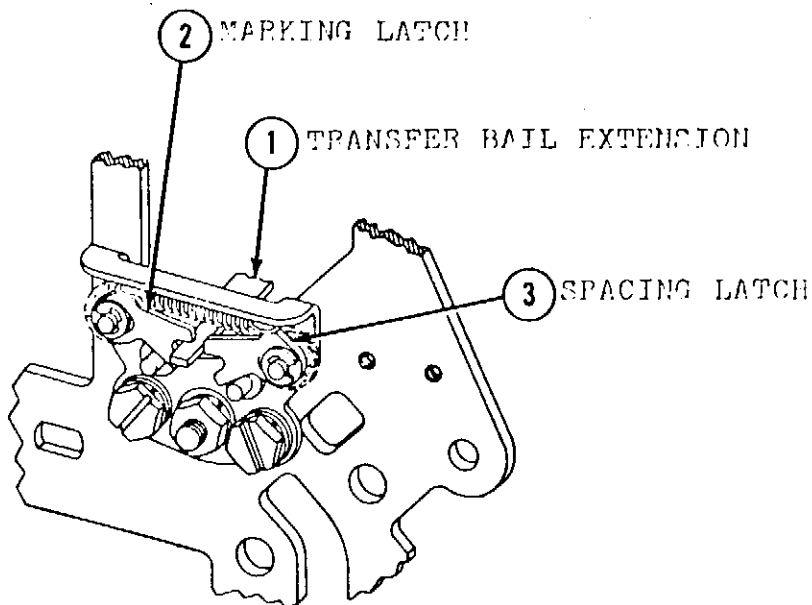

MARKING CONDITION

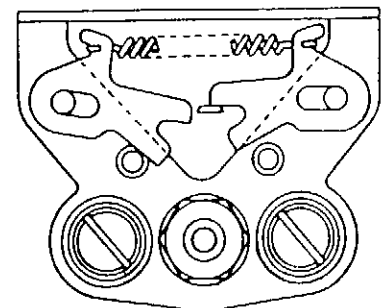

SPACING CONDITION

TRANSFER BAIL EXTENSION (1) locks into place when moving from a Mark to Space or a Space to Mark.

Marking Condition:

TRANSFER BAIL EXTENSION (1) rotates counterclockwise allowing MARKING LATCH (2) to ride on top of TRANSFER BAIL EXTENSION (1) while SPACING LATCH (3) drops down on right side of TRANSFER BAIL EXTENSION (1) to hold Transfer Bail Marking.

Spacing Condition:

TRANSFER BAIL EXTENSION (1) rotates clockwise allowing SPACING LATCH (3) to ride on top of TRANSFER BAIL EXTENSION (1) while MARKING LATCH (2) drops down on left side of TRANSFER BAIL EXTENSION (1) to hold Transfer Bail Spacing.

FOR INSTRUCTIONAL PURPOSES ONLY

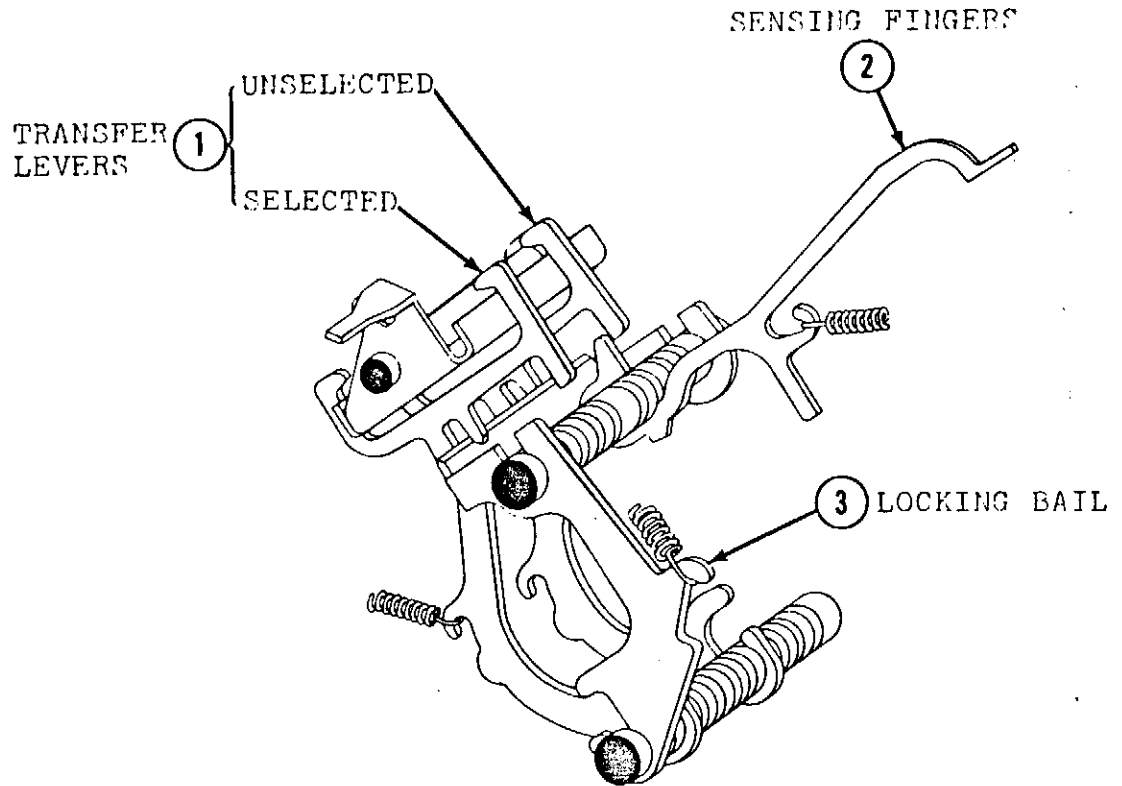

TRANSFER LEVERS (1) are placed in either a selected or an unselected position by their associated SENSING FINGERS (2). Cam Shaft rotates allowing the spring loaded LOCKING BAIL (3) to enter its dwell. The locking blade of the LOCKING BAIL (3) positions between the lower extensions, locking selection into place until transmission is completed. LOCKING BAIL (3) is carried out of TRANSFER LEVERS (1) at the end of Cam Shaft cycle.