

INSTRUCTIONS FOR INSTALLING PAPER WINDER LPW300** ON
 TELETYPE MODEL 28,32,33,34, OR 35 CONSOLE CABINET (LAC OR
 LAAC); MODIFICATION KIT 195259** PERTINENT TO MODEL 32 OR
 33 CONSOLE CABINET

The following chart pertains to Bell System only:

| UNIT | TELETYPE CODE | BELL SYSTEM CODE |
|--|---------------|------------------|
| Paper Winder | LPW300** | 1A** |
| Refer to standardized information for Adjustments, Lubrication and Wiring. | | |

1. GENERAL

a. The LPW300** Paper Winder is capable of winding paper from a Model 28,32,33, 34 or 35 Console Printer Set. The paper winder accommodates paper widths from 4-1/4 to 8-1/2 inches. The capacity of the winder is 400 feet of 8-1/2 inch (.0034 to .0043 inch thick) paper when operated in conjunction with Model 28,34, or 35 Friction Feed Printers or approximately 320 feet of 8-1/2 inch paper when operated in conjunction with Model 32 or 33 Friction Feed Page Printers.

NOTE

The LPW300** Paper Winder is to be used only on Sets having FRICITION FEED PRINTERS. The LPW300** Paper Winder is not to be used with Sets having Sprocket Feed Printers.

b. A 193950 Copy Display Rack is required when the paper winder is installed on a Model 28,34 or 35 Set. This copy display rack must be ordered as a separate item.

c. A 195259** Modification Kit is required when the paper winder is to be installed on a Model 32 or 33 Console Cabinet. This modification kit includes an appropriate copy display rack and must be ordered as a separate item. The kit provides easy removal of the winder for access to the removable cabinet back panel.

d. The paper winder motor operates on 115 Volts AC \pm 10%, 50/60 cycle current. The spindle of the paper winder is driven directly by the motor shaft - there are no clutches, gears or pulleys. The 162958 Mercury Switch controls the motor current.

e. The following loose parts are found in a bag attached to the frame of the LPW300** Paper Winder:

| | | | | | |
|---|------|--------------|---|--------|-----------------------|
| 4 | 1253 | Screw | 1 | 97347 | Screw, Set |
| 4 | 3646 | Washer, Lock | 1 | 114466 | Connector, Receptacle |

| | | | | | |
|---|--------|-----------------|---|--------|--------------------|
| 1 | 5830WD | Diagram, Wiring | 3 | 151626 | Terminal (Spade) |
| 4 | 49514 | Nut | 2 | 165255 | Screw, Sheet Metal |
| 2 | 49612 | Screw | 1 | 193951 | Guide, Paper |
| 4 | 78469 | Bumper, Rubber | 2 | 192007 | Terminal |

f. The 195259** Modification Kit consists of:

| | | | | | |
|---|--------|--------------------------------|---|----------|--------------------|
| 4 | 2191 | Washer, Lock | 1 | 195253 | Rack, Copy Display |
| 4 | 6345 | Nut | 2 | 195256** | Hanger |
| 4 | 195180 | Bumper w/Threaded Extension | | | |

g. For parts ordering information refer to Teletype Parts Bulletin 1129B.

h. The double asterisks (**) denote a suffix which indicates the color of the paint finish.

2. INSTALLATION (Figures 1, 2 and 3)

NOTE

For parts referred to, other than the components of the paper winder or the modification kit, refer to the appropriate Teletype Parts Bulletin.

a. Installing LPW300** Paper Winder on Model 28 Console Cabinet (Figure 1).

(1) Remove 152797** Plate w/Screws and 151532** Cover w/Plate from rear of cabinet by removing two 6345 Nuts, 2191 Lock Washers and 7002 Washers. Discard the parts and mounting hardware.

(2) Mount the paper winder at the rear of the cabinet, using two holes made available in preceding Paragraph (1), two lower holes present in the cabinet, four 1253 Screws, 3646 Lock Washers and 49514 Nuts. See Figure 1.

b. Installing LPW300** Paper Winder on Model 32 or 33 Console Cabinet using the associated 195259** Modification Kit (Figure 2).

(1) Loosen the screw securing the 193953** Motor Housing to the winder and remove the housing.

(2) Remove the two resistor leads from the terminal block assembly and tape the resistor leads from interference with other wiring and moving parts.

(3) Adjust the winder mercury switch per Servicing Section (Paragraph 4.a.). Replace the 193953** Motor Housing and tighten the retaining screw.

(4) Secure the two 195256** Hangers to the paper winder using four 195180 Bumpers w/Threaded Extensions, 2191 Lock Washers and 6345 Nuts. See Figure 2.

(5) Looking at the rear of the cabinet, hook the right hanger over the top ledge of the removable panel. Tilt the lower end of the winder outward slightly and slide the winder to the right until the left hanger engages the ledge of the panel. See Figure 2. Position winder for alignment of winder spindle with typing unit platen.

c. Installing LPW300** Paper Winder on Model 34 or 35 Console Cabinet (Figure 3).

(1) Remove 152797** Plate w/Screws and 192116** Cover w/Plate from rear of cabinet by removing two 6345 Nuts, 2191 Lock Washers and 7002 Washers. Discard the parts and mounting hardware.

(2) Mount the paper winder at the rear of the cabinet using two holes made available in preceding Paragraph (1), two 78469 Rubber Bumpers, 49612 Screws, 3646 Lock Washers, 49514 Nuts, two lower holes present on later cabinet, two 78469 Rubber Bumpers and 165255 Sheet Metal Screws. See Figure 3.

NOTE

If the cabinet does not have the two lower holes they must be added. Use the frame of the paper winder as a template and spot or mark the location of the two lower mounting holes of the winder on the cabinet. Drill two .125 inch diameter holes (1/8 inch Drill) in the cabinet. Make certain that no metal chips get into the winder and printer set mechanisms.

3. MISCELLANEOUS INFORMATION AND INSTRUCTIONS (Figures 1, 4 and 5)

a. The 114466 Receptacle Connector is provided with the paper winder. This connector mates with the connector on the winder power cord which is approximately 18 inches long. The customer must furnish the wiring between the connector and an AC power source. Three 151626 Terminals (Spade) and two 192007 Terminals (one is a spare) are provided for use in making the following wiring connections:

(1) For Model 28 Console Cabinet - The three 151626 Terminals may be used when power is to be obtained from the "C" terminal board of the cabinet.

(2) For Model 32 or 33 Console Cabinet - The three 151626 Terminals may be used when power is to be obtained from the set at terminals 1 and 2 of the "TS" terminal board and terminal 4 of the motor control relay.

(3) For Model 34 or 35 Console Cabinet - Two of the 151626 Terminals and a 192007 Terminal may be used when power is to be obtained from terminals 1 and 2 of the "K" terminal board of the call control unit and terminal AA5 of the electrical service unit.

b. The operation of the paper winder ON-OFF switch should be checked to determine whether the slack bail and its associated mercury switch activate the winder spindle. If necessary, check the Mercury Switch Position Adjustment in SERVICING Paragraph 4.

- c. Insert appropriate copy display rack into its locating holes on the paper winder frame. See Figure 1.
- d. See Figure 4 for path of paper from printer unit to paper winder spindle.
- e. Check alignment of paper with paper winder spindle. If necessary, adjust paper in typing unit. Make certain that the paper fingers on the typing unit are in the proper location.
- g. For narrow paper, assemble the 193951 Paper Guide to the slack bail for the applicable width of paper and secure the paper guide using the 97347 Set Screw.

4. SERVICING (Figure 5)

CAUTION

Disconnect power to paper winder before servicing.

a. Adjustments - Mercury Switch Position. The glass enclosed leads of the switch must be positioned so that the mercury makes contact with the two leads simultaneously when the switch is activated. The mercury switch should start the motor when the following clearances are present between the lower edge of the paper slack bail and the paper slack bail backstop:

For operation with Model 28,34, and 35 Apparatus: $\frac{3}{4}$ to $1\frac{1}{4}$ inches.

For operation with Model 32 and 33 Apparatus: $\frac{1}{8}$ to $\frac{5}{8}$ inches.

NOTE

The LPW300 Paper Winders are adjusted for operation with Model 28, 34, and 35 Apparatus when shipped from the factory.

To adjust, loosen the switch mounting screw and position the switch. See Figures 5 and 6.

b. Lubrication

- (1) Motor Bearing - Apply several drops of KS7470 - Oil.
- (2) Paper Slack Bail - One drop of KS7470 Oil at each pivot point.

5. THEORY OF OPERATION

The paper is guided over the copy display rack, underneath the paper slack bail to the paper winder spindle. The paper slack bail will be in the lowermost position.

Consequently the mercury switch mounted on the paper slack bail will be ON and the motor will be operating. The drive pin on the motor shaft will engage the flange rod, thereby winding the paper. As the paper winds the slack bail will be raised and the mercury switch will tilt to the OFF position. Current will then flow through a resistor connected across the mercury switch. Further operation of the motor is prevented, thereby minimizing the pull on the printer paper-feeding mechanism. Approximately ten lines (single space) will have to be fed out before the slack bail will again be in position to start the winder motor through the action of the mercury switch.

*

*

*

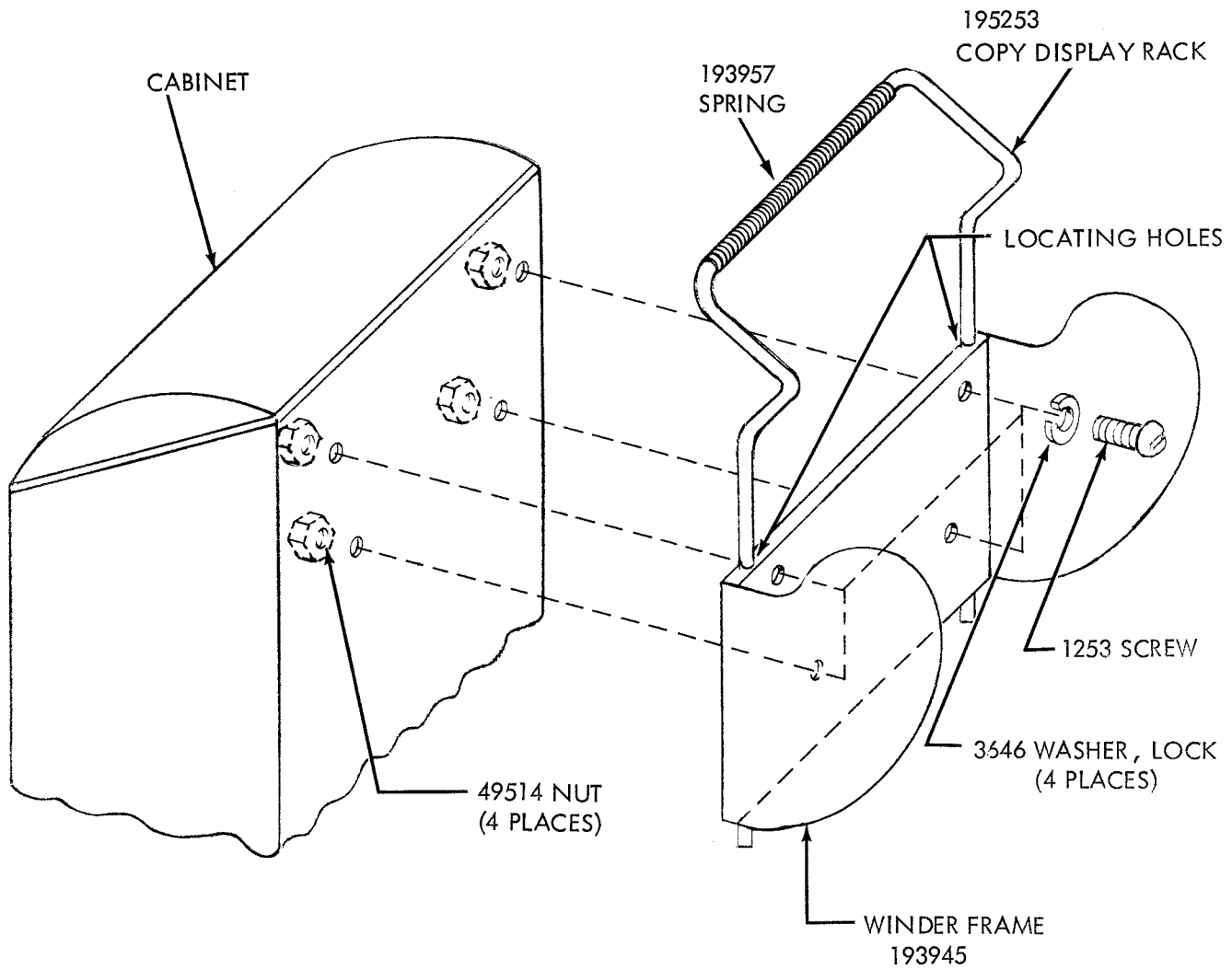

FIGURE 1. INSTALLING LPW300** PAPER WINDER ON A MODEL 28 CONSOLE CABINET (LAC OR LAAC)

50143S

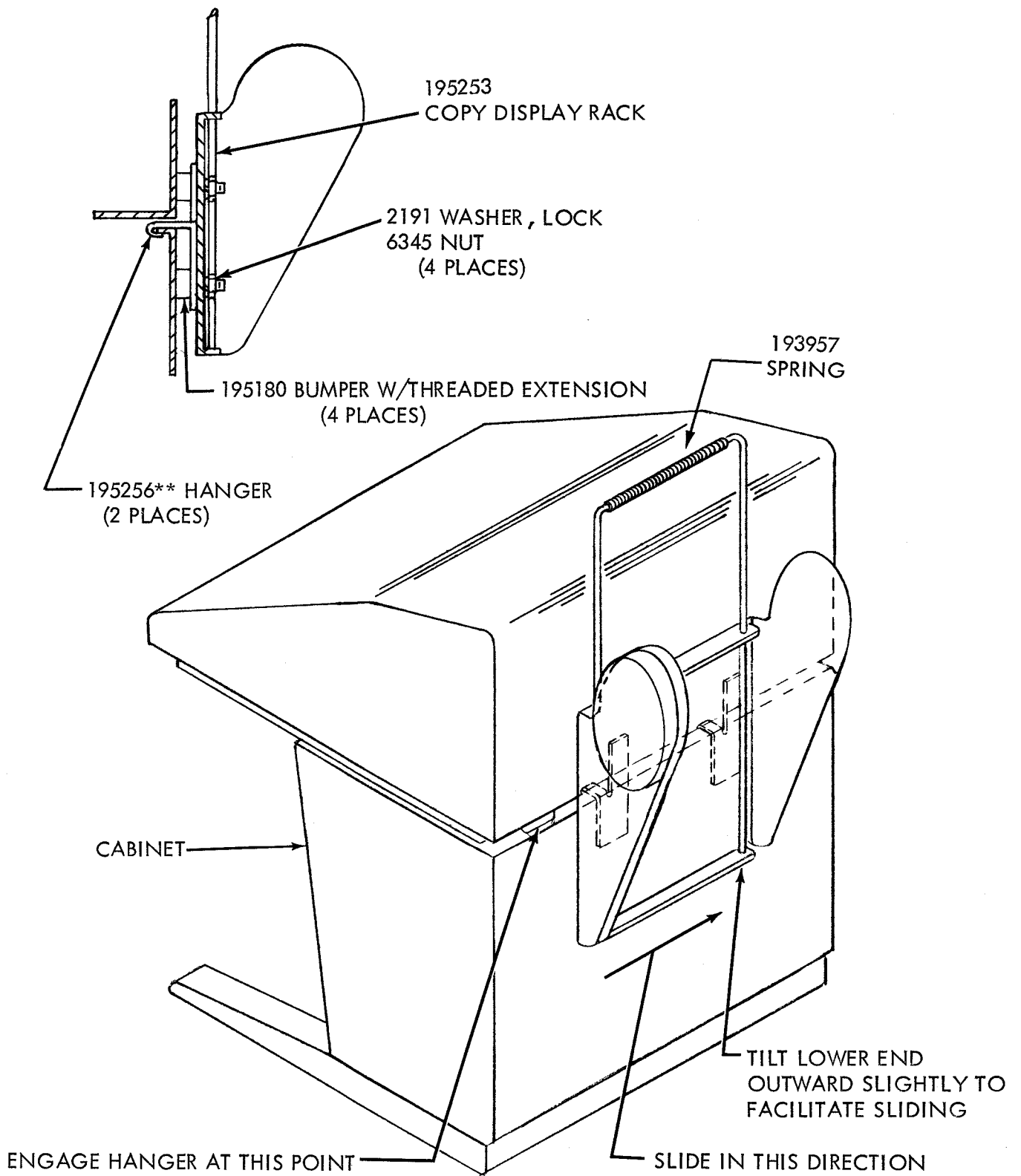

FIGURE 2. INSTALLING LPW300** PAPER WINDER ON A MODEL 32 OR 33
CONSOLE CABINET USING 195259** MODIFICATION KIT

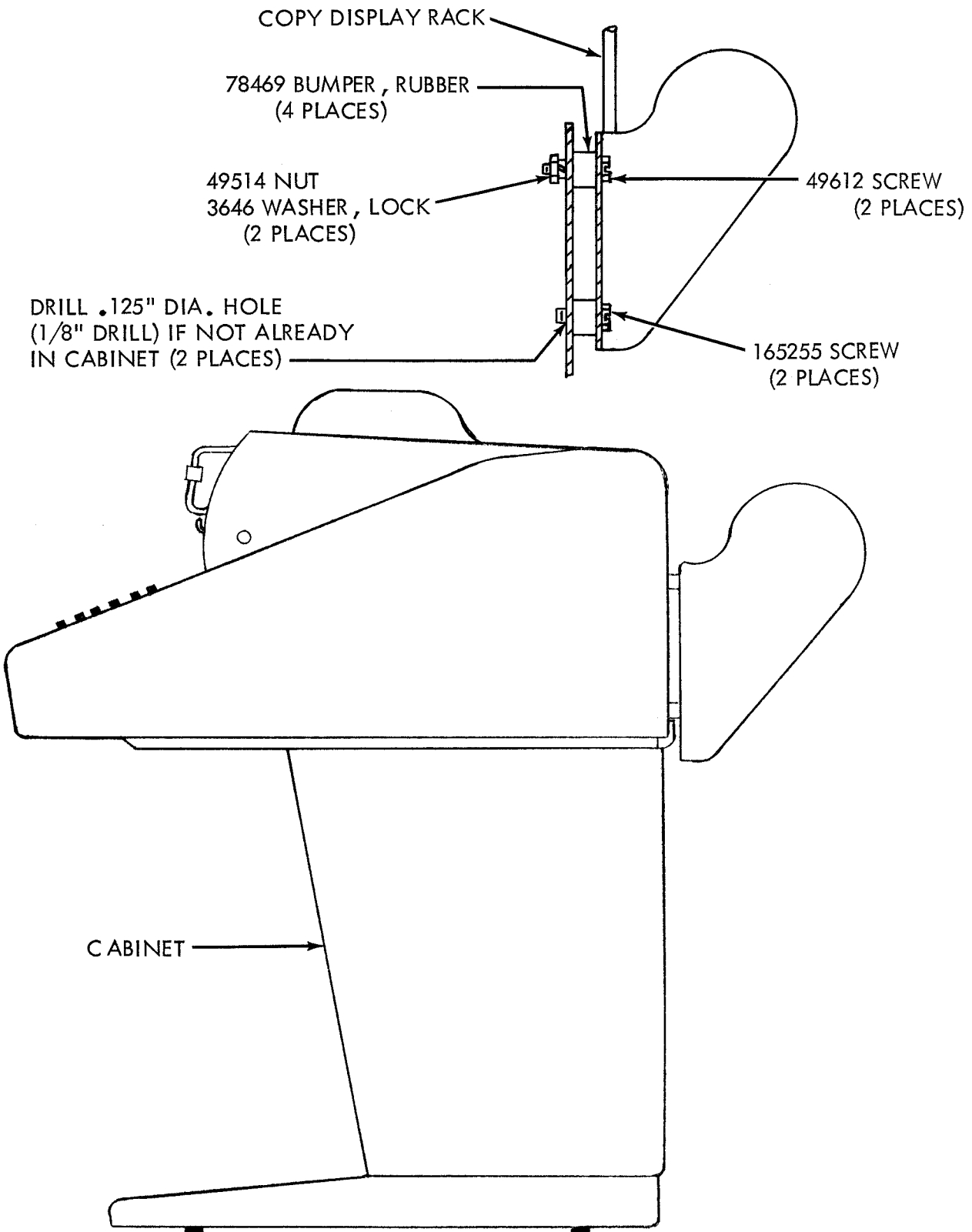

FIGURE 3. INSTALLING LPW300** PAPER WINDER ON A
MODEL 34 OR 35 CONSOLE CABINET

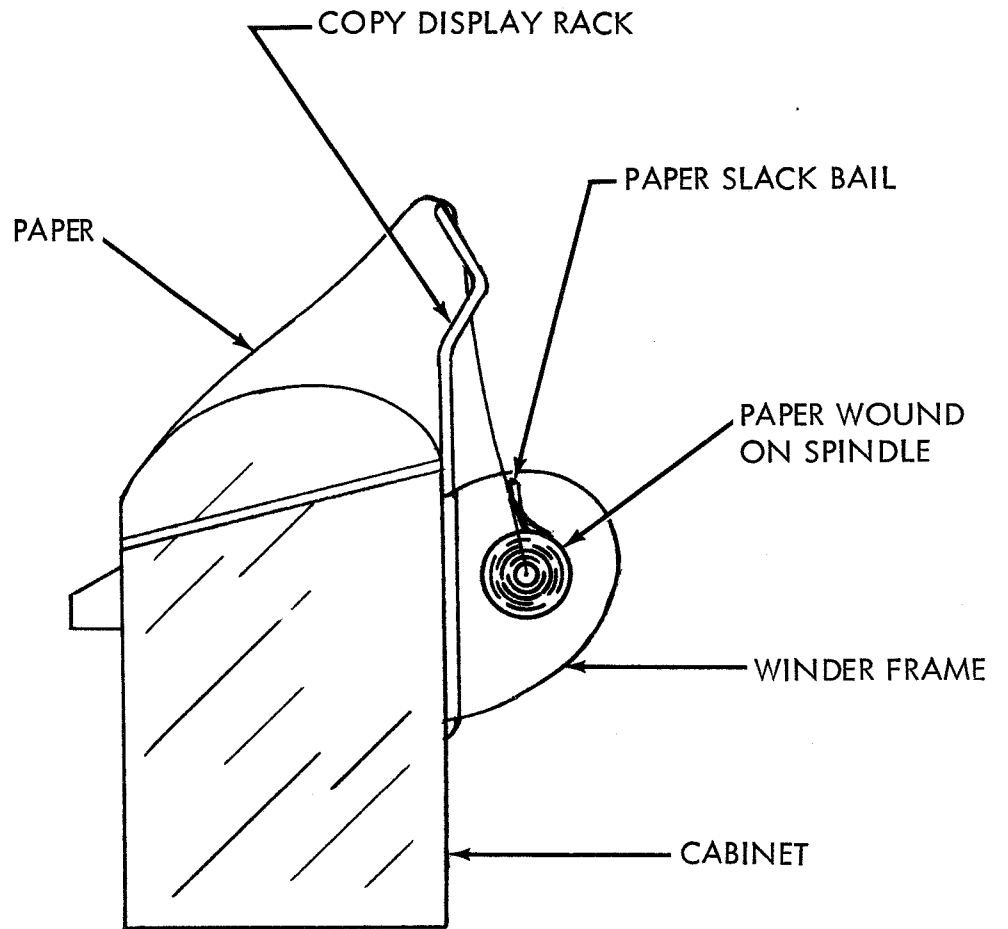

FIGURE 4. PATH OF PAPER FROM PRINTER UNIT TO PAPER WINDER SPINDLE

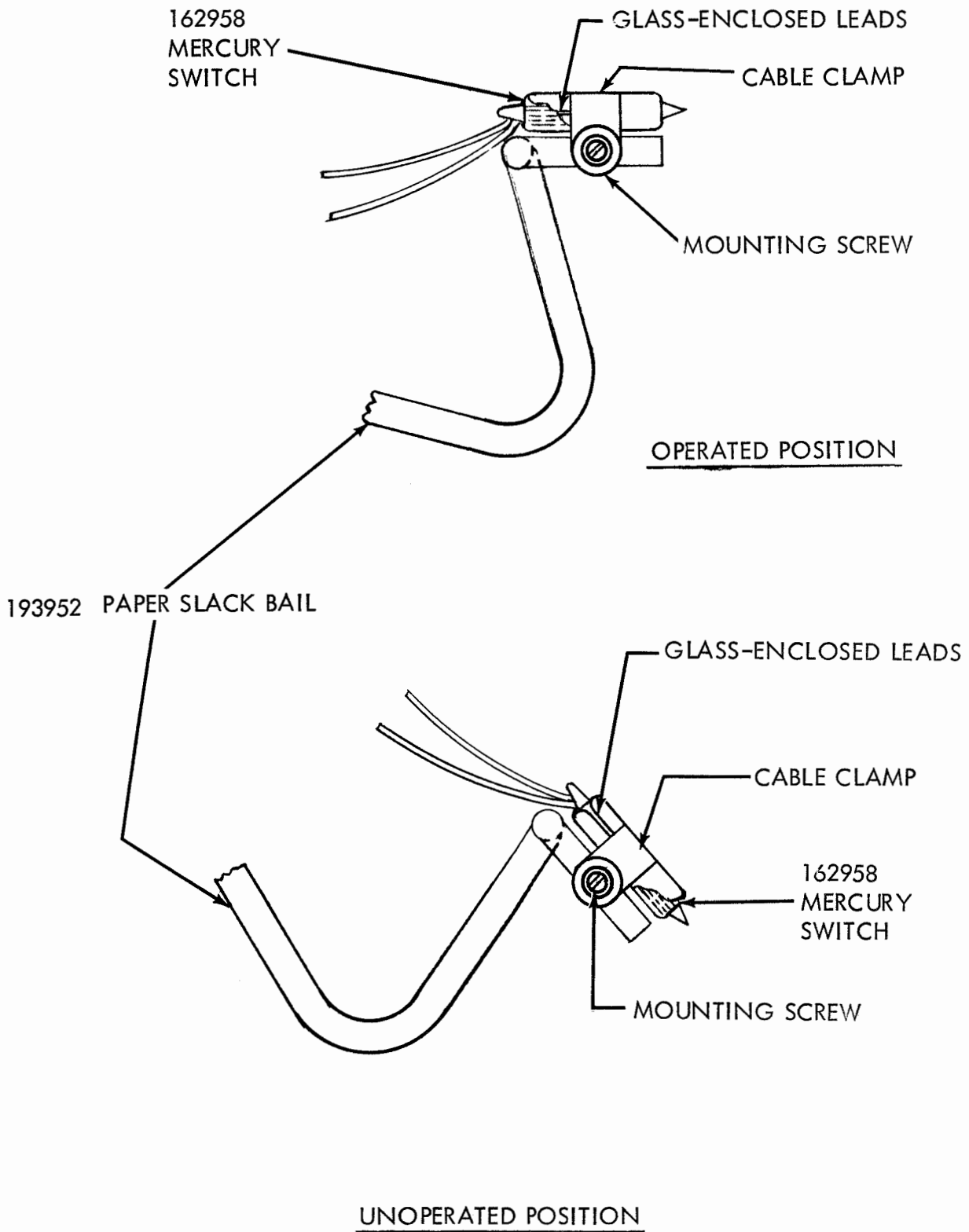

FIGURE 5. OPERATION OF THE MERCURY SWITCH ON THE LPW300** PAPER WINDER

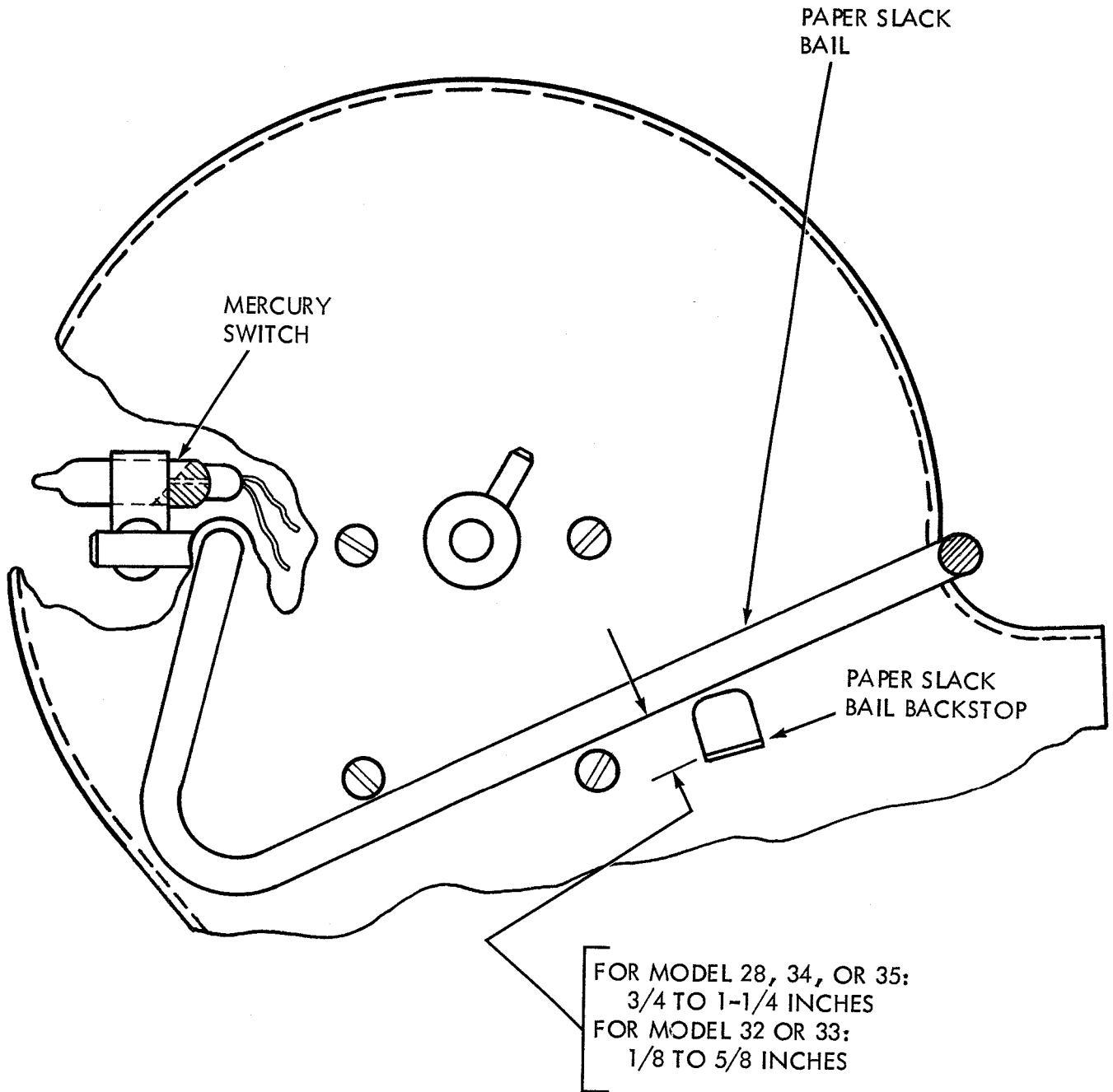

FIGURE 6

| NOTE |
|---|
| WIRING LEGEND ↖ DISTANT TERM. AREA ↘ DISTANT TERM. DESIG. A-1-R ↑ WIRE COLOR CODE |
| COLOR CODE: R-RED W-WHITE BK-BLACK |
| MATING CONNECTOR 114466 IS FURNISHED WITH UNIT. WIRING BETWEEN A.C. POWER AND 114466 IS TO BE PROVIDED IN FIELD AT INSTALLATION TIME. |
| MOTOR OPERATES ON 50-60 CYCLE 110 V.A.C. |
| THE NUMBERS ENCLOSED BY PARENTHESIS ARE USED FOR REFERENCE AND ARE NOT SHOWN ON THE PART. |

FIGURE 7

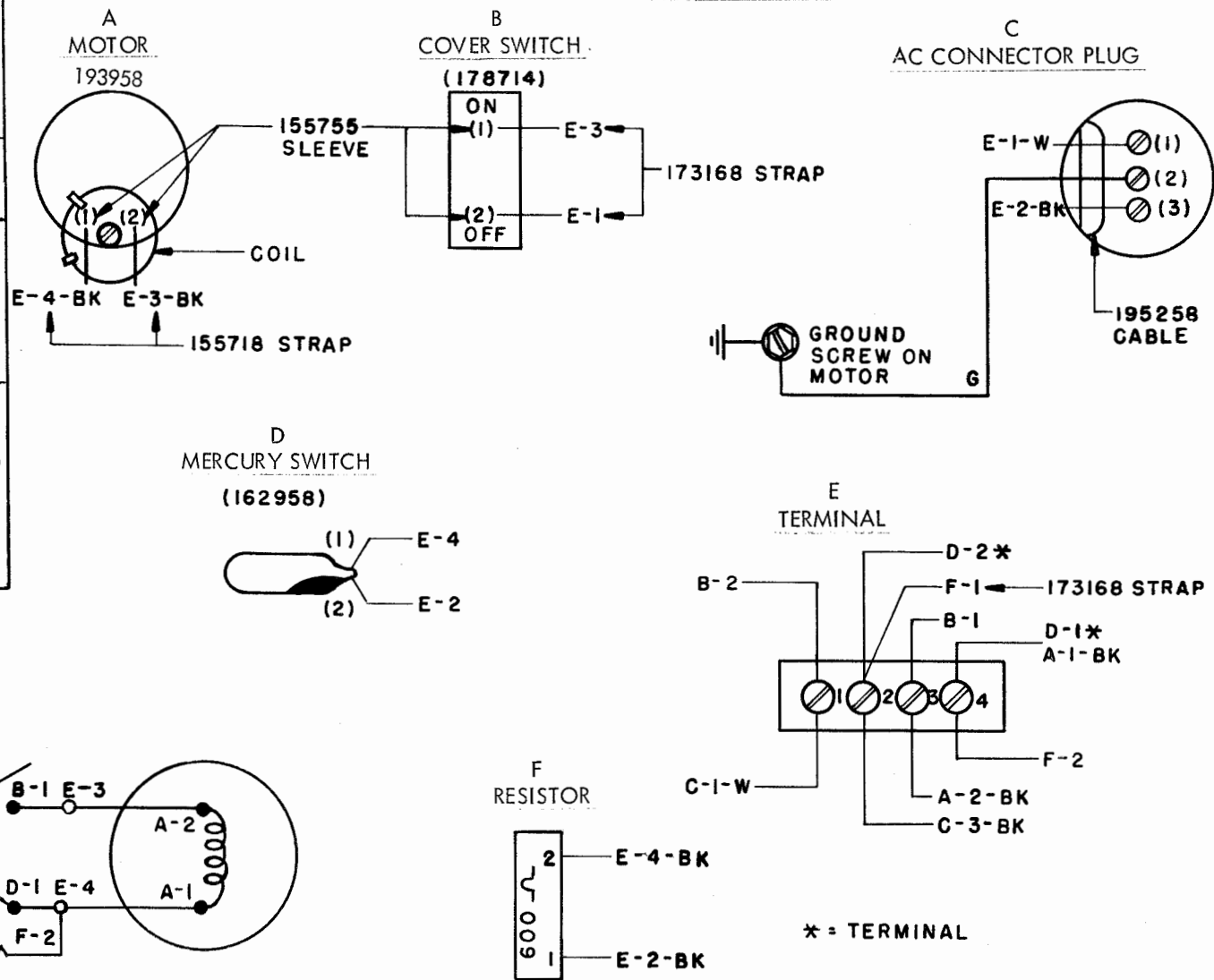

FIGURE 6. TYPICAL WIRING DIAGRAM FOR PAPER WINDER