



TELETYPE  
CORPORATION



PEDESTAL  
BASED



TABLETOP

# the **42** teleprinter

## SERVICE MANUAL

for BUFFERED KSR and ASR  
PEDESTAL BASED and TABLETOP VERSIONS

NOTE :

Blank pages and  
packaging instructions  
have been deleted to  
conserve space.



D R HOUSE TECHNICAL SERVICES

Don Robert House N.S.E.  
Graphic Designs and Technical Publishing

4716 Patty Lane  
Country Crossings  
Ringwood IL 60072

(815) 459-9861 iPhone  
(815) 653-0684 FAX  
drhouse42@iCloud.com  
[www.nadcomm.com](http://www.nadcomm.com)

1980 by Teletype Corporation

Printed in U.S.A.

# THE 42 BUFFERED KSR AND ASR TELEPRINTERS

## SERVICE MANUAL

### INTRODUCTION

This manual provides service information for the pedestal based and tabletop version of the 42 Buffered KSR and ASR Teleprinters. The parts included in the service manual provide instructions for use by craft personnel when performing the servicing tasks required for the installation, testing, troubleshooting and routine maintenance of the 42 Buffered KSR and ASR Teleprinters.

The task flow chart on the following page illustrates the intended servicing activities and associated manual parts.

A brief training course and the maintenance spares as recommended in the parts indexes are available from Teletype Corporation. Craft personnel should be properly trained and have access to maintenance spares before attempting to service the 42 Buffered KSR and ASR Teleprinters.

This manual was reissued to provide servicing information for 42 Buffered Teleprinters with 230 Vac power supplies and to include those with enhanced features.

For complete repair information on 42 Teleprinters including repair of all major components, refer to the following manuals which may be ordered from your Teletype Corporation Engineering Graphics Department 5412, 5555 W. Touhy Avenue, Skokie, Illinois 60077.

MANUAL	DESCRIPTION
385	Circuit Diagram Manual for Circuit Cards Used in 42/43 and 45 30 CPS Character Printer Terminal and Associated Units
522	Repair Manual for TTL and SSI Logic Cards Used in 42/43 and 45 30 CPS Character Printers
523	Repair Manual for Power Supplies Used in 42/43 and 45 Character Printer Terminals
525	Repair Manual for Keyboards Used in 42/43 Basic Terminals
530	Repair Manual for SSI Keyboards Used in 42/43 Buffered Terminals
533	Parts Manual for Enclosures, Paper Handling and Miscellaneous Accessories Used with 42/43 and 45 30 CPS Character Printers
534	Repair Manual for Interfaces Used in and with 42/43 Terminals (Includes AB, SCU, and Brief Repair of Non-Pedestal Controllers)
539	Repair Manual for 42/43 and 45 30 CPS Character Printer Mechanisms

MANUAL 425

TASK FLOW AND PAGE REFERENCES

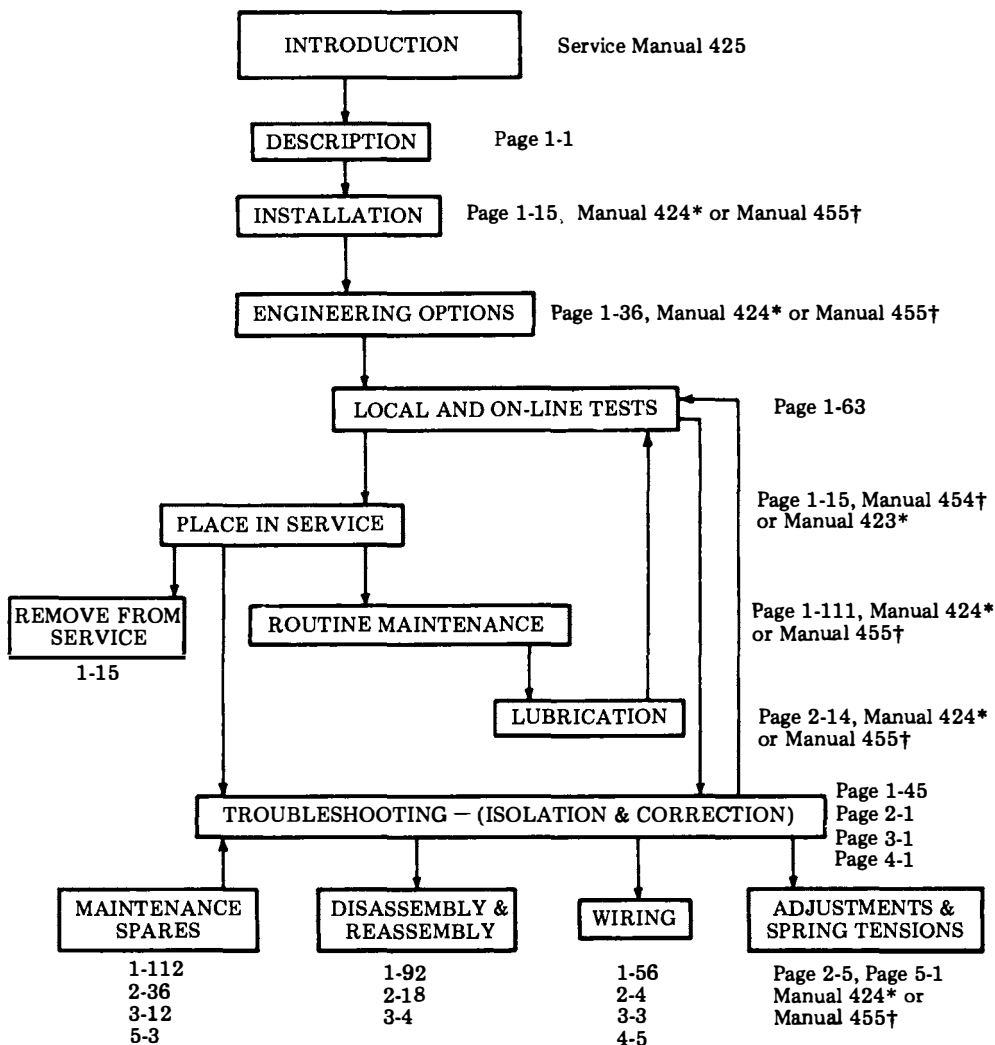

\*Included with each pedestal based terminal shipped.

†Included with each tabletop terminal shipped.

PART	DESCRIPTION
1	42 BUFFERED KSR AND ASR TELEPRINTERS
2	42 PRINTER
3	42 BUFFERED KEYBOARD
4	42 BUFFERED CONTROLLER
5	42 BUFFERED PAPER HANDLING AND ENCLOSURES

## PART 1 — 42 BUFFERED KSR AND ASR TELEPRINTER

INDEX	PAGE
A. GENERAL DESCRIPTION.....	1-1
B. INSTALLATION AND REMOVAL .....	1-15
C. ENGINEERING OPTIONS.....	1-36
D. TROUBLESHOOTING.....	1-45
E. WIRING .....	1-56
F. TESTING .....	1-63
G. DISASSEMBLY/REASSEMBLY.....	1-92
H. ROUTINE MAINTENANCE.....	1-111
I. PARTS .....	1-112
J. CONVERSIONS — PEDESTAL BASED.....	1-115

PART 1 — 42 BUFFERED KSR AND ASR TELEPRINTER

A. GENERAL DESCRIPTION

<u>CONTENTS</u>	<u>PAGE</u>
1. GENERAL .....	1-1
2. DESCRIPTION (Pedestal Based).....	1-2
3. DESCRIPTION (Tabletop) .....	1-7
4. DESCRIPTION PT UNIT CONTROLS AND INDICATORS.....	1-12
5. REFERENCES .....	1-14

1. GENERAL

- 1.01 This part provides a general description of the 42 Buffered KSR and ASR Teleprinter.
- 1.02 There are two versions of the 42 buffered teleprinter. One is the pedestal

based version having a controller located in the pedestal of the terminal. The other is the tabletop version having a controller located within the rear bustle cover.

1.03 Each version is available as a KSR or an ASR having a PT (Paper Tape) unit which includes a punch and a reader.

1.04 Since the tabletop version can be mounted on a pedestal and the pedestal based version can be remotely mounted from its pedestal with controller, the two versions can be identified as follows:

- (a) The pedestal based version has a nine-pin molex connector located at the left rear of the bustle cover.
- (b) The tabletop version has a twenty-five pin EIA connector located at the left rear of the bustle cover.

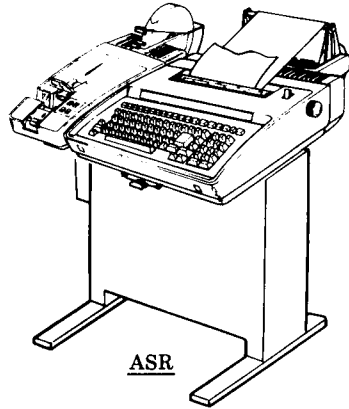
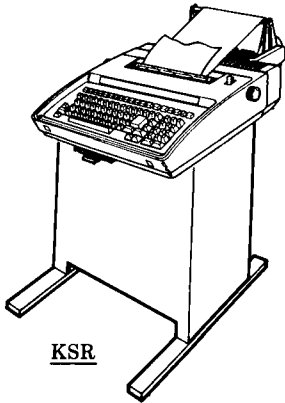

Fig. 1—42 Buffered Pedestal Based KSR and ASR Teleprinters

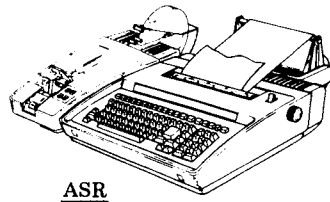
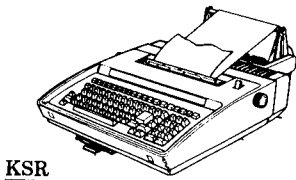

Fig. 2--42 Buffered Tabletop KSR and ASR Teleprinters

### A. GENERAL DESCRIPTION (Contd)

#### 1. GENERAL (Contd)

1.05 For detailed information on the PT unit (paper tape) for an ASR arrangement, refer to Service Manual 422.

#### 2. DESCRIPTION (Pedestal Based)

2.01 The 42 buffered KSR and ASR teleprinters are available with a memory buffer size of 4,000 or 20,000 characters.

2.02 The teleprinter provides for off-line data preparation (message enter, edit and store) and batch transmission. The ASR also has the capabilities of preparing punched paper tape messages off-line, receiving punched paper tape messages on-line, and transmission on-line from a paper tape reader.

2.03 Operating speeds are 0050, 0075, 0100 or 0225 baud using a 5-level 7.5 unit code in a half-duplex operation. Printout is on an 80 column, 10 character per inch matrix style printer utilizing 8-1/2 inch wide friction feed paper. A 7 by 9 dot matrix produces the character shapes and special symbols for control codes.

2.04 The line interface is 20 to 60 mA 120 Vdc or 20 to 40 mA 60 Vdc externally provided.

2.05 Standard single-ply 8-1/2 inch wide, 5 inch diameter roll paper is used on friction feed printers.

2.06 Paper tape for the PT unit (ASR) must be 11/16-inch wide oiled paper furnished in eight inch maximum diameter rolls with two inch diameter spindle hole. The tape must be 0.004 inch thick, 50 pound basic paper and must meet ANSI Standard X3.29.

2.07 Inking is provided by a readily replaceable cartridge with ribbon (430035). A package of six cartridges (430484) is available from Teletype Corporation.

2.08 The 42 buffered teleprinters operate on 115 Vac  $\pm 10$  percent at 50 or 60 Hz. See ENGINEERING OPTIONS, Page 1-36 to operate the PT unit (ASR) at 50 Hz. Power to the KP set is approximately 75 watts and is controlled by an on-off rocker switch located at the right rear of the housing. Power to the controller is approximately 30 watts and is not switch controlled. Power to the PT unit (ASR) is approximately 100 watts and is controlled by an on-off rocker switch located at the left rear of the housing.

2.09 The KP set weighs 31 pounds and the pedestal with controller and power supply weighs 31 pounds. The PT unit (ASR) weighs 20 pounds.

2.10 The operational controls and status indicators for the teleprinters are briefly described in Fig. 4.



<u>TERMINAL CODE</u>	<u>DESCRIPTION</u>	<u>KP SET CODE</u>	<u>PT UNIT CODE</u>	<u>CONTROLLER</u>
4230/AAA	4K Buffer (F)	4320/AAS	4250/AAA	43C105
4240/AAA	4K Buffer (F)	4320/AAS	None	43C105

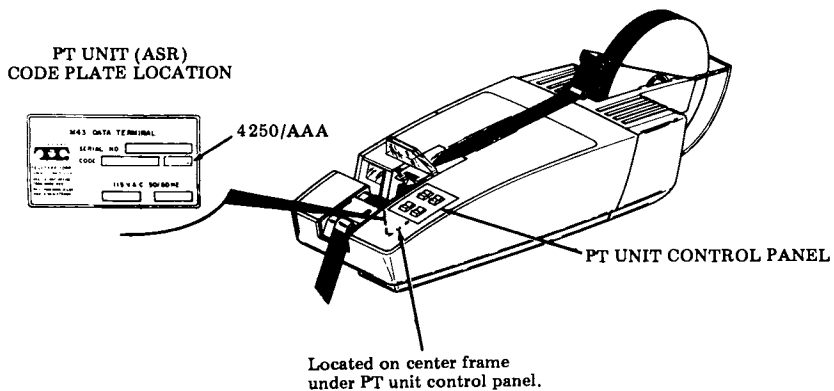
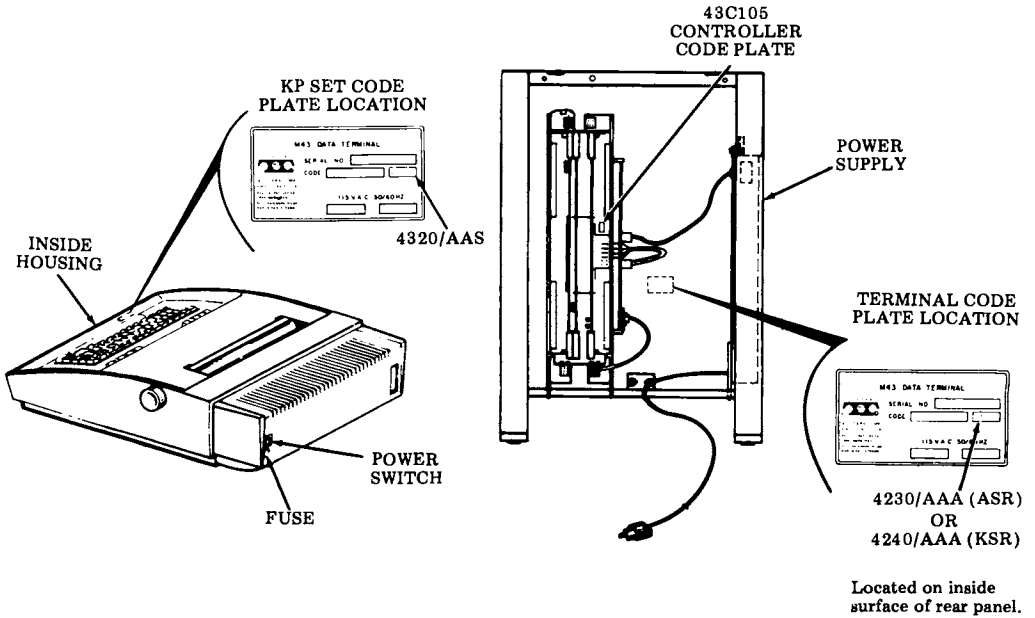

Fig. 3-42 Buffered KSR and ASR Pedestal Based Teleprinter Identification

A. GENERAL DESCRIPTION (Contd)

2. DESCRIPTION (Pedestal Based) (Contd)

\* Lamp lit indicates when terminal is ready to answer a call. If off-line, depressing initiates request to dial. Lamp extinguishes when go ahead message prints. Depressing when on-line causes call to disconnect. Depressing while dialing aborts dialing procedure.

† Depressing initiates a request to dial if KP lamp and TRM RDY keys are lit. Lamp flashes until a proceed signal is returned from exchange. Lamp lights steady when proceed signal is received.

Indicator only -- Lamp lights when all conditions are proper for on-line communication.

When lit terminal will not answer or initiate a call. If depressed while lit, places terminal in a ready condition. If flashing, terminal is in option prep mode. If depressed while in options prep mode aborts all currently modified option values.

When lamp is on, terminal is in ENTER state, keyboarded data is put in Edit Buffer and associated controls may be used. Depressing key toggles state. (In ENTER state, KP is automatically placed in LOCAL. When exiting the Enter state, KP remains LOCAL.) Lamp flashes at Edit Buffer full warning.

When lamp is on, keyboarded characters are inserted at Edit Pointer and remainder of message is pushed down. Depressing key toggles state. Lamp may flash momentarily when entering or existing mode. Active only in the ENTER mode.

Depressing this key places the terminal in a mode to accept a string of up to the last 26 characters entered when the lamp is on. Active only in ENTER mode. String is used for comparison in SEARCH, or RETRIEVE. Second depression turns off lamp and exits mode. Old string is deleted when lamp comes on.

\*BLOCKING KEYTOP

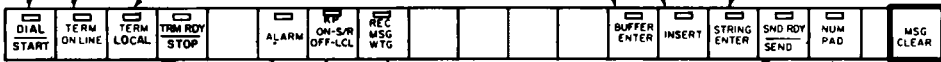

† Lamp lit indicates when terminal is ready to answer a call. Depress to light. Depressing when on-line disconnects call. Depressing while dialing aborts dialing procedure.

Lamp is on for alarm states. (Low paper, paper-out, cover open, or in TEST mode.) Push to reset after clearing alarm condition if lit.

Press to send from Send Buffer; press to stop sending. Lamp on, if message is waiting to be sent. Lamp flashing if sending. Send until end of Send Buffer, or message ending character sent or push key.

When lamp is on, the function of the 14 key cluster at right side of keyboard is a Numeric Pad as a primary function using the upper designations. When lamp is off, the lower designations are active. Notice edit functions are active when Numeric Pad is enabled only with CONTROL, or SHIFT key. Push key to change state. Remainder of keyboard is unaffected by NUM PAD mode.

When lamp is on, KP is in S/R mode. When off, KP is LOCAL, even though terminal may be on-line. Depressing key toggles state. If flashing, printer is seized. Depress to clear flashing.

Lamp indicates Receive Buffer contains characters that have not been sent to printer. Depressing key causes printing to commence. (KP goes to S/R mode and ENTER, if on, is exited.) Lamp flashes when RBWf is reached.

In ENTER mode, depressing this key causes the contents of the Edit Buffer to be cleared from the Edit Pointer to the next message ending character.

\*Unique to RCA Global Arrangement  
 †Unique to Western Union Arrangement

Fig. 4—Operational Controls and Status Indicators — Pedestal Based

2.11 The basic keyboard is shown in Fig. 5 along with brief descriptions on the operation of several special keys.

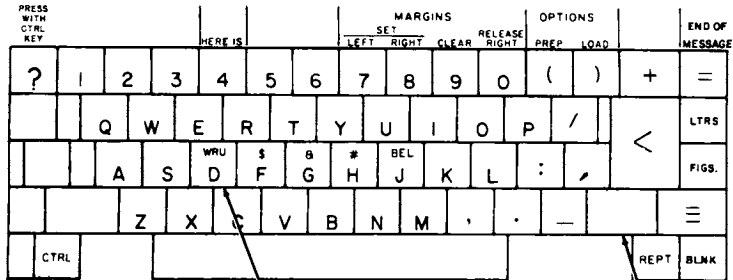

Depress and hold while selected key is depressed to perform special control function on-line. This key is also used during local operations for setting margins, options preparation and load and answer-back.

Unmarked shift key — Used for keyboard test only. Second shift key located on left side of opcon.

WRU and other special control character keys (keys with abbreviations at top of key) when depressed together with the CTRL key (codes are sent on-line), print or perform special functions.

When the CTRL and < keys are operated together, the carriage is returned and the paper advances one line regardless of how key is optioned. No character is sent on-line.

Fig. 5—Basic Keyboard Layout — Pedestal Based

## A. GENERAL DESCRIPTION (Contd)

### 2. DESCRIPTION (Pedestal Based) (Contd)

2.12 The functions of the numeric/edit pad are briefly described in Fig. 6.

In the ENTER mode, depressing this key returns the Edit Pointer to the beginning of the current line and printer to carriage return. If at the beginning of the line, the Edit Pointer moves to the beginning of the previous line and the printer line feeds. In NUM PAD mode, this key generates numeral 8. In the OPTIONS PREP mode, this key is used to step backwards through the option list.

In the ENTER mode, depressing this key causes the contents of the Edit Buffer to be printed from the current location of Edit Pointer. A second depression will stop printing. In NUM PAD mode, this key generates the numeral 7. Printing stops at msg end char.

In the ENTER mode, depressing this key causes the printer carriage to move left one character position and decrements the Edit Pointer by one. Operation will not proceed beyond the carriage return, line feed, or other format effector. In the NUM PAD mode, this key generates the numeral 4.

In the ENTER mode this key is depressed to execute a search in the was sent buffer for a string. The "found" message containing the string is appended to the end of the Edit Buffer, the line containing the string is printed through the last character of the string and the Edit Pointer will be positioned on the next character following the last character in the string. If the string is not found, the printer will print "Cannot Find" and the Edit Pointer remains at its original position. In the NUM PAD mode, this key generates the numeral 1.

In the ENTER mode, depressing this key causes the character at the current Edit Pointer position to be erased and the remaining contents of the Edit Buffer to be moved forward one position to fill the void created. The printer will overwrite the existing character with a block and move one character to the right. In the NUM PAD mode, this key generates the character comma.

In the ENTER mode, all the unsent or sent but unacknowledged contents of the Send Buffer are transferred back to the Edit Buffer (ie, the Edit Home is moved to the Send Home position. In the NUM PAD mode, this key generates the character sequence as optioned for the large return key in the user option memory.

In the ENTER mode, depressing this key causes the contents of the Edit Buffer from home to the first message ending character to be designated send buffer, ie, Edit Home is moved to the character beyond the end of the first message in the Edit Buffer. In the NUM PAD mode, this key generates the minus sign.

In the ENTER mode, depressing this key causes the Edit Pointer to move to the beginning of the Edit Buffer and the printer to perform a carriage return, line feed. In the NUM PAD mode, this key generates the numeral 5.

In the ENTER mode, depressing this key causes the entire contents of the Edit Buffer to be printed starting at the Edit Pointer with a unique graphic for each control character. In this mode, the format effectors will be ignored and all printing will be from left margin to right boundary. A second depression of key will stop printing. Printing stops at msg end char. In NUM PAD, this key generates the numeral 9.

In the ENTER mode, depressing this key causes the printer carriage to move one character to the right, printing the character or performing the function at the current Edit Pointer location and incrementing the Edit Pointer position by one. This key is not line bounded. In the NUM PAD mode, this key generated the numeral 6.

In the ENTER mode, depression of this key will cause a search in the Edit Buffer for the string. When found, the line containing the string up through the last character in the string will be printed and the Edit Pointer will be positioned on the first character following the string. If the string is not found, the printer will print "Cannot Find" and pointer will remain at its original position. In the NUM PAD mode, this key generates the numeral 3.

In the TERM LOCAL mode with the KP in LOCAL, depressing this key will recall a message from the Receive Buffer to be reprinted. The receive message waiting lamp will come on. Printing will occur when the KP is in S/R mode. To stop printing, set KP to LOCAL. In the NUM PAD mode, this key generates the period or decimal.

In the ENTER mode, depressing this key causes the Edit Pointer to move to the character following the next line feed (ie, beginning of next line). The printer will perform a carriage return, line feed. In the NUM PAD mode, this key generates the numeral 2. In the options prep mode, this key signifies that editing of one line is complete.

This key functions only in the NUM PAD mode and generates the numeral 0 (zero).

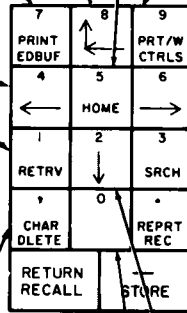

Fig. 6—Numeric/Edit Pad — Pedestal Based

### 3. DESCRIPTION (Tabletop)

- 3.01 The 42 Buffered KSR and ASR teleprinters have a memory buffer of 16,000 characters.
- 3.02 The teleprinter provides for off-line data preparation (message enter, edit and store) and batch transmission. The ASR also has the capabilities of preparing punched paper tape messages off-line, receiving punched paper tape messages on-line, and transmission on-line, from a paper tape reader.
- 3.03 Operating speeds are 0045, 0050, 0075, 0100, 0200 or 0225 baud using a 5-level 7.5 unit code in a half-duplex operation. Print-out is on an 80 column, 10 character per inch matrix style printer utilizing 8-1/2 inch wide friction feed paper. A 7 by 9 dot matrix produces the character shapes and special symbols for control codes.
- 3.04 The line interface at the rear of the teleprinter is EIA-type signals. Connected to the EIA interface is one of two line interfaces, 403103 or 420301. The 403103 line interface is used for neutral current signaling. The 420301 line interface is used for neutral current signaling or polar signaling. These two line interfaces are not covered in this manual. Refer to Specification 50998S for the 403103 line interface or Specification 51048S for the 420301 line interface.
- 3.05 Standard single-ply 8-1/2 inch wide, 5 inch diameter roll paper is used on friction feed printers.
- 3.06 Paper tape for the PT unit (ASR) must be 11/16-inch wide oiled paper furnished in eight inch maximum diameter rolls with two inch diameter spindle hole. The tape must be 0.004 inch thick, 50 pound basic paper and must meet ANSI Standard X3.29.
- 3.07 Inking is provided by a readily replaceable cartridge with ribbon (430035). A package of six cartridges (430484) is available from Teletype Corporation.
- 3.08 The 42 buffered teleprinter operates on 115 Vac  $\pm 10$  percent at 50 or 60 Hz. or 230 Vac  $\pm 10$  percent at 50 or 60 Hz. See ENGINEERING OPTIONS Page 1-36 to operate the PT unit (ASR) at 50 Hz. Power to the KSR set is approximately 75 watts and is controlled by an on-off rocker switch located at the right rear of the housing. Power to the PT unit (ASR) is approximately 100 watts and is controlled by an on-off rocker switch located at the left rear of the housing.
- 3.09 The KSR set weighs 31 pounds and the PT unit (ASR) weighs 20 pounds.
- 3.10 The operational controls and status indicators for the teleprinters are briefly described in Fig. 8.

A. GENERAL DESCRIPTION (Contd)

3. DESCRIPTION (Tabletop) (Contd)

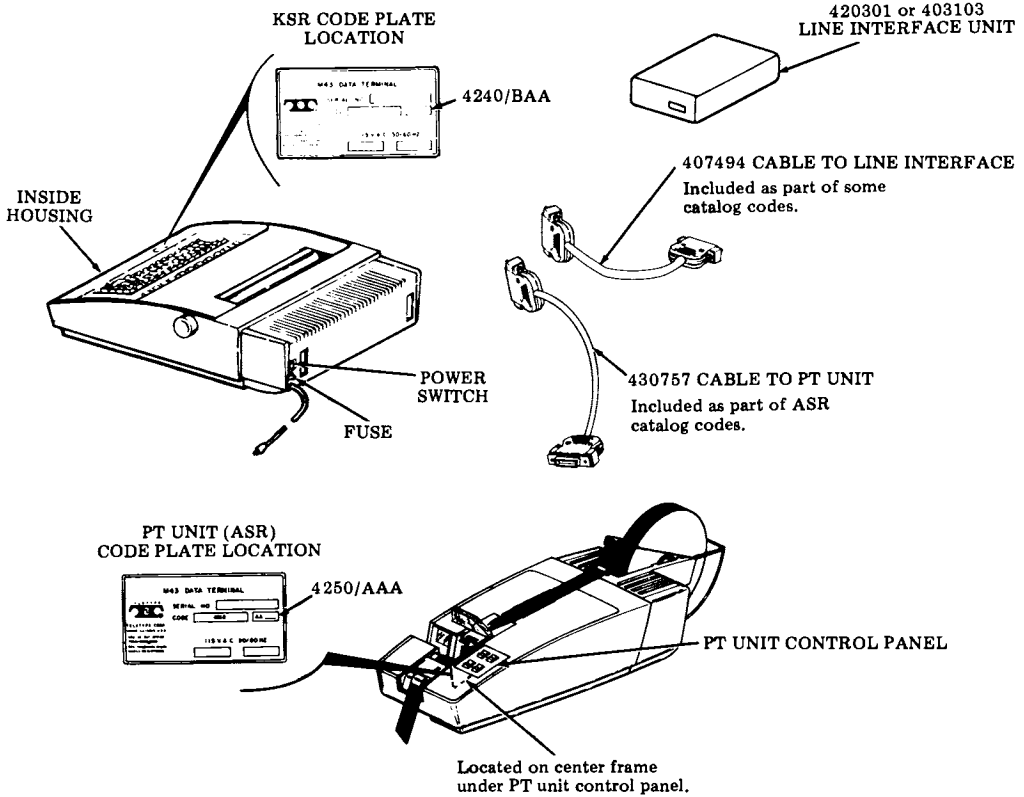

Fig. 7-42 Buffered KSR and ASR Tabletop Teleprinter Identification

Protocol 1 or 3 arrangement only— Depressing key initiates a request to dial if IN SERVICE key is lit. Lamp flashes until a proceed signal is returned from exchange. Indicator on steady when proceed signal is received.

Protocol 2 or 4 arrangement only — Depressing key initiates a request to dial. ON-LINE indicator flashes then goes on steady. The exchange sends Go Ahead message (GA) which will print. Terminal is ready for dialing.

Indicator only — Lights when all conditions are proper for on-line communication. Flashes when sending a line "break".

Depressing key will cause ON-LINE indicator to flash and then remain off when exchange drops the line (disconnects).

When depressed, the first 60 characters of every message in the entire send and receive buffer (edit, send, was sent, and receive buffers, in that order) are printed. A second depression will cause printing to stop. Active in LOCAL PREP mode only. Flashes while printing out directory, turns off when printout is complete.

When indicator is on, the keyboard, printer, and paper tape unit (ASR) are dedicated to local, off-line data preparation. Terminal will answer and store incoming calls if alarm is not on or the receive buffer warning (RBufW) point has not been reached. This stored message may be printed by depressing this key.

Depression causes KP to enter the edit mode, even though the terminal may be on-line. Both MEMORY and LOCAL PREP indicators turn on and the edit pointer is placed after the last character in the buffer. In the edit mode, messages can be entered in the buffer from the keyboard or reader (ASR), edited as necessary and stored. Lamp flashes when edit/send buffer is nearly full. (EBWrn).

Active only in the MEMORY or options prep mode. Depression causes the contents of the edit buffer to be cleared from the current location in the buffer through the next message-ending character, or the end of the edit buffer if no message ending character is encountered.

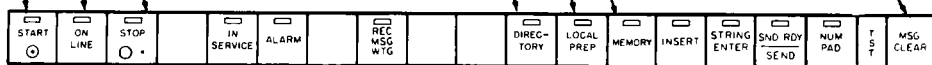

When indicator is on, terminal is normally ready for on-line operation. A call may be initiated, but not answered, with a low paper or low tape alarm. Calls may not be initiated or answered with other alarm conditions.

Indicator turns on as a warning due to low paper, low tape (ASR), cover open or in test mode. After condition has been cleared, depressing the key may be required to turn off the alarm indicator. Terminal will return to the state it was in prior to the alarm. A call may be initiated, but not answered, with a low paper or low tape alarm.

Lamp turns on when receive buffer contains messages waiting to be printed. Depressing key causes printing and punching of messages (ASR) if punch is on. Depressing LOCAL PREP key when lamp is on will also cause printing and punching (ASR). When all messages have been printed, lamp will turn off. Lamp flashes when RBufW (receive buffer warning) is reached.

Active only in the MEMORY mode otherwise bell rings. Depressing key turns lamp on; when lamp is on, keyboard characters are inserted in the edit buffer at the current buffer location. Any data following the inserted data will be shifted toward the end of the edit buffer as characters are inserted until the edit buffer is full. Depress key to end insertion mode. Wait until indicator stops flashing before proceeding.

Active only in the MEMORY mode. Depressing key clears any previously entered string and allows terminal to accept a new string of up to 16 characters (lamp turns on). If more than 16 characters are entered, only the last 16 characters are accepted. The string is used for comparison in buffer search or retrieve modes. Depress key to turn off lamp and exit mode. Mode is also exited when the search or retrieve is executed or home key is depressed.

Lamp turns on when message is waiting to be sent from send buffer as a result of depressing the STORE key. When lamp is on, depress key to send. Lamp flashes while sending. Sending continues until the message ending character or the end of the send buffer is encountered, or the SEND key is depressed again.

When the lamp is off, the 14-key cluster at the right side of the keyboard performs editing functions (lower designations). When the lamp is turned on by depressing the key, the cluster functions as a Numeric Pad.

Fig. 8—Operational Controls and Status Indicators — Tabletop

A. GENERAL DESCRIPTION (Contd)

3. DESCRIPTION (Tabletop) (Contd)

3.11 The basic keyboard is shown in Fig. 9 along with brief descriptions on the operation of several special keys.

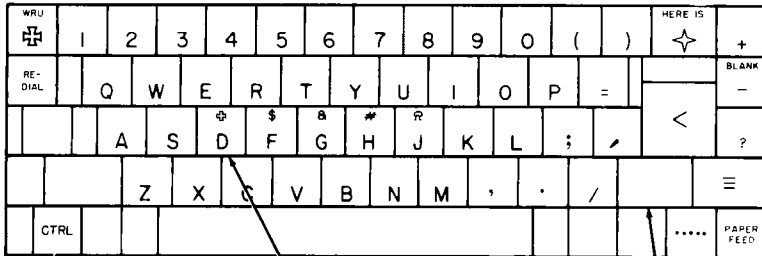

Depress and hold while selected key is depressed to perform special control function on-line. This key is also used during local operations for setting margins, options preparation and load and answer-back.

WRU and other special control character keys (keys with abbreviations at top of key) when depressed together with the CTRL key (codes are sent on-line), print or perform special functions.

Unmarked shift key — Used for keyboard test only. Second shift key located on left side of opcon.

When the CTRL and < keys are operated together, the carriage is returned and the paper advances one line regardless of how key is optioned. No character is sent on-line.

Fig. 9—Basic Keyboard Layout — Tabletop



3.12 The functions of the numeric/edit pad are described in Fig. 10.

In the MEMORY mode, depressing this key returns the Edit Pointer to the beginning of the current line and printer to carriage return. If at the beginning of the line, the Edit Pointer moves to the beginning of the previous line and the printer line feeds. In NUM PAD mode, this key generates numeral 8. In the OPTIONS PREP mode, this key is used to step backwards through the option list.

In the MEMORY mode, depressing this key causes the contents of the Edit Buffer to be printed from the current location of Edit Pointer. A second depression will stop printing. In NUM PAD mode, this key generates the numeral 7. Printing stops at msg end char.

In the MEMORY mode, depressing this key causes the printer carriage to move left one character position and decrements the Edit Pointer by one. Operation will not proceed beyond the carriage return, line feed, or other format effector. In the NUM PAD mode, this key generates the numeral 4.

In the MEMORY mode this key is depressed to execute a search in the sent buffer for a string. The "found" message containing the string is appended to the end of the Edit Buffer, the line containing the string is printed through the last character of the string and the Edit Pointer will be positioned on the next character following the last character in the string. If the string is not found, the printer will print "???" and the Edit Pointer remains at its original position. In the NUM PAD mode, this key generates the numeral 1.

In the MEMORY mode, depressing this key causes the character at the current Edit Pointer position to be erased and the remaining contents of the Edit Buffer to be moved forward one position to fill the void created. The printer will overprint the existing character with a block and move one character to the right. In the NUM PAD mode, this key generates the character comma.

In the LOCAL PREP mode depressing this key will cause the printer to horizontally tab to the next tab stop. In the MEMORY mode depressing this key also writes a horizontal tab character into the Edit Buffer. In the NUM PAD mode, this key generates the figures shift character.

In the MEMORY mode, depressing this key causes the Edit Pointer to move to the beginning of the Edit Buffer and the printer to perform a carriage return, line feed. In the NUM PAD mode, this key generates the numeral 5.

In the MEMORY mode, depressing this key causes the entire contents of the Edit Buffer to be printed starting at the Edit Pointer with a unique graphic for each control character. In this mode, the format effectors will be ignored and all printing will be from left margin to right boundary. A second depression of key will stop printing. Printing stops at msg end char. In NUM PAD, this key generates the numeral 9.

In the MEMORY mode, depressing this key causes the printer carriage to move one character to the right, printing the character or performing the function at the current Edit Pointer location and incrementing the Edit Pointer position by one. This key is not line bounded. In the NUM PAD mode, this key generated the numeral 6.

In the MEMORY mode, depression of this key will cause a search in the Edit Buffer from the Edit Pointer to the end of buffer for the string. When found, the line containing the string up through the last character in the string will be printed and the Edit Pointer will be positioned on the first character following the string. If the string is not found, the printer will print "???" and pointer will remain at its original position. In the NUM PAD mode, this key generates the numeral 3.

In the LOCAL PREP mode depressing this key will recall a message from the Receive Buffer to be reprinted. The receive message waiting lamp will come on. Printing will occur when the LOCAL PREP key is depressed. In the NUM PAD mode, this key generates the period or decimal.

In the MEMORY mode, depressing this key causes the Edit Pointer to move to the character following the next line feed (ie, beginning of next line). The printer will perform a carriage return, line feed. In the NUM PAD mode, this key generates the numeral 2. In the options prep mode, this key signifies that editing of one line is complete.

In the MEMORY mode, all the unsent or sent but unacknowledged contents of the Send Buffers are transferred back to the Edit Buffer (ie, the Edit Home is moved to the Send Home position). In the NUM PAD mode, this key generates the numeral 0 (zero).

In the MEMORY mode, depressing this key causes the contents of the Edit Buffer from home to the first message ending character to be designated send buffer, ie, Edit Home is moved to the character beyond the end of the first message in the Edit Buffer. In the NUM PAD mode, this key generates the letters shift character.

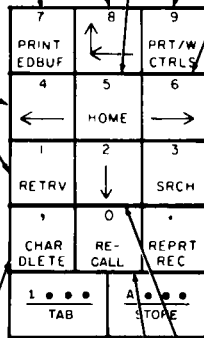

Fig. 10—Numeric/Edit Pad — Tabletop

## A. GENERAL DESCRIPTION (Contd)

### 4. DESCRIPTION PT UNIT CONTROLS AND INDICATORS

4.01 This paragraph describes the PT unit controls and indicators as they apply to the Telex ASR teleprinters. For a complete description of the PT unit, refer to Service Manual 422.

4.02 The punch and reader controls and indications are described in Fig. 11, 12 and 13.

The punch functions as an extension of the printer. In the on position, the punch responds (perforates tape) to all data outputted to the printer whether on-line or local. In the on position, the punch will not respond to punch stop code (FFFF or \$\$\$\$).

In the auto position, the punch will automatically start upon receipt of the punch start code (CCCC or ::::). In the term on-line mode, the punch will start on receipt of the punch start code received from the line, if the KP is in the S/R mode, from the keyboard or from the send buffer. If the KP is in the local mode (terminal on-line or off-line), the keyboard or reader can start the punch (punch start code).

If the punch receives a stop code (FFFF or \$\$\$\$), while operating on-line, from the line, keyboard, reader, or send buffer, the punch will stop punching. If operating in a local mode (KP local) the punch will stop on receipt of a punch stop code from the keyboard or reader.

Operation to the off position stops the punch if it is operating. Any data received while the switch is off will not be punched. Punch will not respond to punch start code.

Indicator is lit steadily whenever the punch is conditioned to perforate tape.

- On/Auto/Off switch in on position.
- On/Auto/Off switch in auto position and after receipt of the punch start code (CCCC or ::::) but before receipt of the punch stop code (FFFF or \$\$\$\$).

Indicator blinks on and off

- If the tape supply is low with the punch control switch in either the on or auto position.

Operation to the feed position causes the punch mechanism to continuously perforate only the sprocket hole and to advance the blank tape as long as the switch is held operated. This operation may be used to prepare "leaders" for separating messages in the tape, or for initiating tape feed when a new supply of tape is entered into the punch. Cannot be operated with punch in auto position.

Operation to the back space position causes the tape to be reverse fed one space position for each operation. No code holes are punched. More than ten successive operations are not recommended. Cannot be operated with punch in auto position.

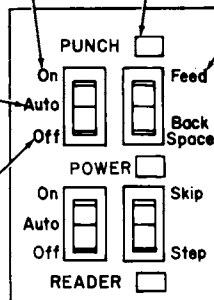

Fig. 11—Punch and Reader Controls and Indicators

Operation to the on position causes the reader to continuously step (if KP is on-line or local) and sense tape. When running, the reader will stop if the gate is opened, the tape runs out or fails to advance, or the tight or tangled tape condition occurs. Correction of the condition causing stoppage allows transmission to be resumed automatically. In this position, reader will not respond to reader off code (AAAA or ----).

In the auto position, the reader will automatically start upon receipt of the reader start code (SSSS or """). In the term on-line mode, the reader will start on receipt of the reader start code received from the line or, if the KP is not in the local mode from the keyboard.

If the KP is in the local mode (terminal on-line or off line) the keyboard can start the reader (reader start code). The reader will transmit locally.

When running, the reader will stop on a tight tape or tangled tape condition and will restart upon removal of the condition. The reader will stop upon sensing the reader stop code (AAAA or ----) in its tape. Up to six additional characters may be read after the reader stop code, therefore six blank characters should be placed on the tape following the reader stop code. If a WRU character is encountered in the tape in the on-line mode, the reader will stop. Six blank characters should be placed after a WRU character in the tape. The reader will also stop when tape runs out or tape lid is opened. If tape lid is opened while reader is running, loss of characters may occur.

Operation to the off position stops the reader if it is operating, and prevents further response to control signals. Restarting is possible in the middle of a message, without loss of data, if the reader gate is not opened.

Indicator is lit whenever power is applied to the PT unit.

With the reader control switch off, operation to the skip position causes the tape to advance one character space, but the character will not be transmitted.

With the reader control switch off, operation to the step position causes the reader feed mechanism to advance one character space, and if tape is present and has moved, causes the transmission of the character in the gate locally or on-line. No action will occur if the reader gate is open, no tape is present in the gate, or tight or tangled tape is present. If tape is in the gate but does not move, due to torn feed holes or improper insertion, the feed mechanism will operate once, but no character will be transmitted.

Indicator is lit steadily whenever the reader is condition to read tape.

- On/Auto/off switch in on position and with tape being sensed.
- On/Auto/Off switch in auto position and after receipt of reader start code (SSSS or """) but before sensing the reader stop code (AAAA or ----) in the tape.

Indicator blinks on and off when:

- On/Auto/Off switch is in the on position, and the tape gate is opened, the tape becomes tight or tangled, runs out, or fails to advance.
- On/Auto/Off switch is in the auto position, after receipt of reader start code (SSSS or """) but before sensing the reader stop code (AAAA or ----) in the tape and the tape gate is opened, the tape becomes tight or tangled, runs out, or fails to advance.

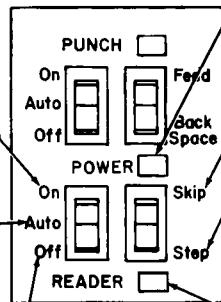

Fig. 11—Punch and Reader Controls and Indicators (Contd)

A. GENERAL DESCRIPTION (Contd)

4. DESCRIPTION PT UNIT CONTROLS AND INDICATORS (Contd)

4.03 The paper tape controls are described in Fig. 12.

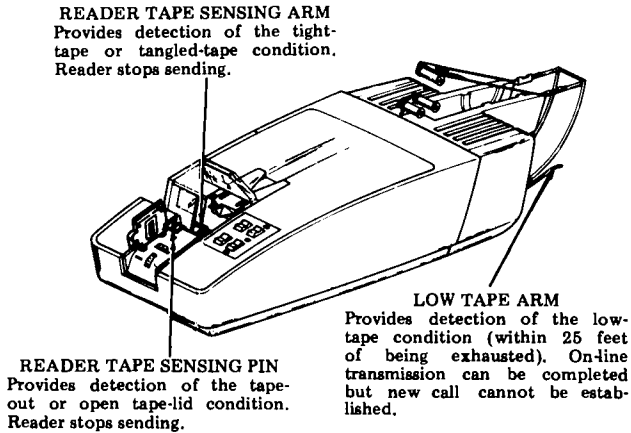

Fig. 12—Paper Tape Controls

4.04 The PT unit auxiliary controls are shown in Fig. 13. The controls must remain in the position shown for Telex application.

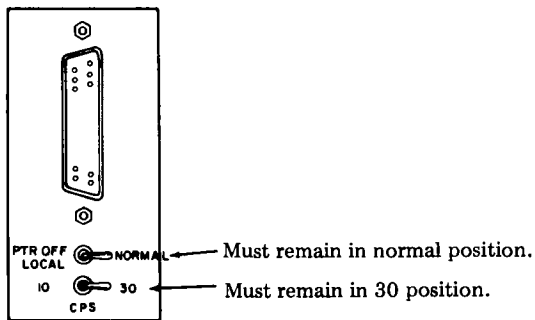

Fig. 13—Auxiliary PT Unit Controls

5. REFERENCES

- 5.01 The 42 buffered teleprinter technical reference provides additional descriptions of the teleprinter components, features and interfacing.
- 5.02 The How to Operate Manuals 423 and 454 provide information on the 42 buffered teleprinter pedestal based and tabletop respectively.

B. INSTALLATION AND REMOVAL

<u>CONTENTS</u>	<u>PAGE</u>
1. GENERAL .....	1-15
2. TOOLS AND MATERIAL REQUIRED .....	1-15
3. INSTALLATION PROCEDURE (Pedestal Based) .....	1-15
A. Unpacking.....	1-15
B. Assembly.....	1-17
C. Ribbon, Paper and Paper Tape (ASR) Installation .....	1-20
D. Checkout Procedure .....	1-20
E. Directory Card .....	1-21
4. KSR STATION REMOVAL (Pedestal Based) .....	1-22
5. ASR STATION REMOVAL (Pedestal Based) .....	1-26
6. INSTALLATION PROCEDURE (Tabletop).....	1-28
A. Unpacking.....	1-28
B. Assembly.....	1-29
C. Ribbon, Paper and Paper Tape (ASR) Installation .....	1-32
D. Checkout Procedure .....	1-32
E. Directory Card .....	1-32
7. STATION REMOVAL (Tabletop).....	1-34
1. <u>GENERAL</u>	
1.01 This part provides installation and removal information for the Pedestal Based and Tabletop 42 Buffered KSR and ASR.	
1.02 Installation should be performed under the direction of a service order, indicating teleprinter code, options, date, materials required and location.	
1.03 For additional information, refer to: F. TESTING, Page 1-63 and ENGINEER- ING OPTIONS, Page 1-36.	

1.04 Before starting the installation procedure, verify that paper, paper tape (ASR), cables, and line interface unit (if required) in addition to the 42 KSR or ASR are present at the installation location.

1.05 Some or all station removal and installation procedures may be used for local station relocation.

1.06 Reference on the procedures to left or right and up or down and top or bottom, etc., refer to the terminal in its normal operative position.

1.07 When ordering replaceable components, unless otherwise specified, prefix each part number with the letters "TP" (ie, TP410324).

2. TOOLS AND MATERIAL REQUIRED

2.01 A 100982 screwdriver, 1/4-inch, 6-inch blade, is required to secure wires to the Telex lines or cables to the PT unit (ASR) and line interface unit (if present). A 129534 1/4-inch wrench is required to remove the pedestal rear panel to remove or install packing details. Packing detail numbers are shown in Fig 10 through 14 for Pedestal Based KSR, Fig. 15 through 17 for Pedestal Based ASR and Fig. 23 for Tabletop Terminals.

3. INSTALLATION PROCEDURE  
(Pedestal Based)

A. Unpacking

3.01 Select an area to unpack the carton so that damage to the terminal will not occur.

3.02 When unpacking, be sure to wear approved safety glasses.

*Caution: To avoid condensation on the electrical components, the terminal should be allowed to assume room temperature before unpacking, for example, when brought into a warm humid room from outside subzero temperatures.*

## B. INSTALLATION AND REMOVAL (Contd)

### 3. INSTALLATION PROCEDURE (Pedestal Base) (Contd)

#### A. Unpacking (Contd)

3.03 The 42 Buffered KSR or ASR Teleprinter is furnished in a single carton containing the KP set and a pedestal containing the controller, power supply and interconnecting SSI cable. If the teleprinter is an ASR it also includes a PT (Paper Tape) unit and interconnecting cable to the PT unit.

3.04 Unpack the carton referring to instructions on the container. Remove tape securing the cover to the housing and if ASR also remove tape securing the PT unit. See Fig. 1.

*Note:* Observe all "Caution" notes printed on the carton.

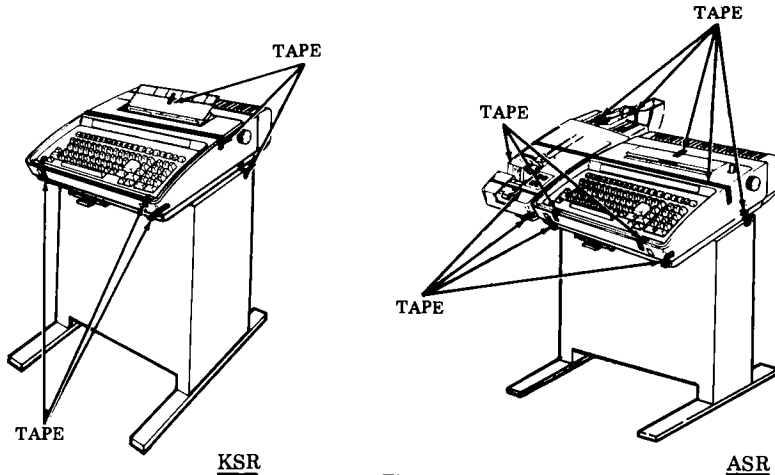

Fig. 1

3.05 Depress the KP set cover locking tabs on the lower front of the cabinet and lift the cover. Remove the ribbon and packing detail securing the print head in place (Fig. 2).

3.06 The containers and other packing details should be retained and reused by field locations to facilitate movement of stations.

3.07 Verify that the following items are included in the box:

- 1 — Set — 42 KP (4320AAS)
- 1 — Pedestal with Controller, Power Supply and Cables
- 1 — Paper Supply Assembly
- 1 — Ribbon
- 1 — PT Unit (ASR only) 4250AAA
- 1 — Chad Box (ASR only)
- 1 — Manual, Installation and Routine Servicing, 424
- 1 — Manual, How To Operate, 423
- 1 — Manual, Installation and Routine Service, 421 (ASR only)
- 1 — Manual, How To Operate, 420 (ASR only)

*Note:* 8-1/2 inch wide by 5 inch diameter rolls (Friction Feed) must be obtained locally or ordered separately. Paper tape for the PT unit (ASR) must be 11/16-inch wide oiled paper furnished in eight inch maximum diameter rolls with two inch diameter spindle hole. The tape should be 0.004 inch thick, 50 pound basic paper and must meet ANSI Standard X3.29.

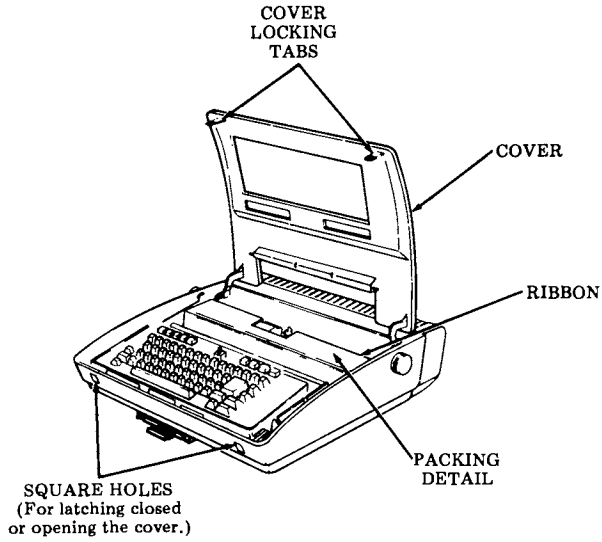

Fig. 2—Packing Detail

B. Assembly

3.08 ASR only — Insert the chad box flanges into the channels of the left side of the pedestal and slide the box fully rearward.

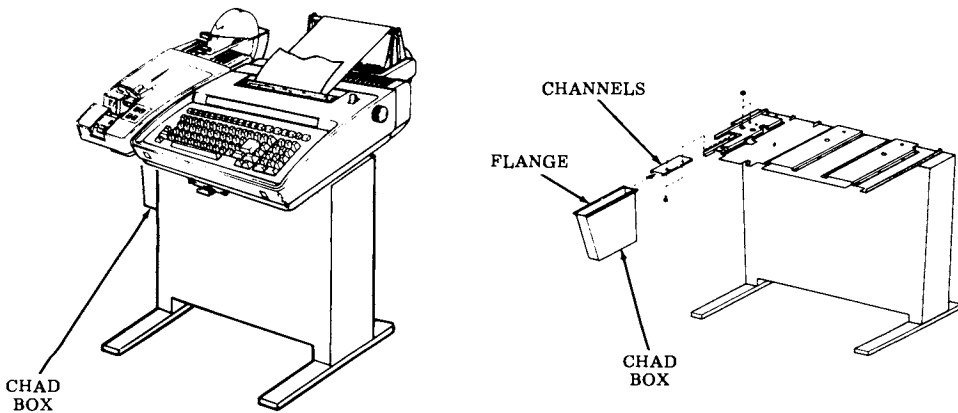

Fig. 3

## B. INSTALLATION AND REMOVAL (Contd)

### 3. INSTALLATION PROCEDURE (Pedestal Base) (Contd)

#### B. Assembly (Contd)

- 3.09 Remove the back panel by removing the two mounting screws, tilting the panel rearwards and lifting it out. See Fig. 4.
- 3.10 ASR only — With power cord removed from ac voltage source, turn on convenience ac output strip.
- 3.11 Check and install Options 455 and 456. See C. ENGINEERING OPTIONS, Page 1-36.

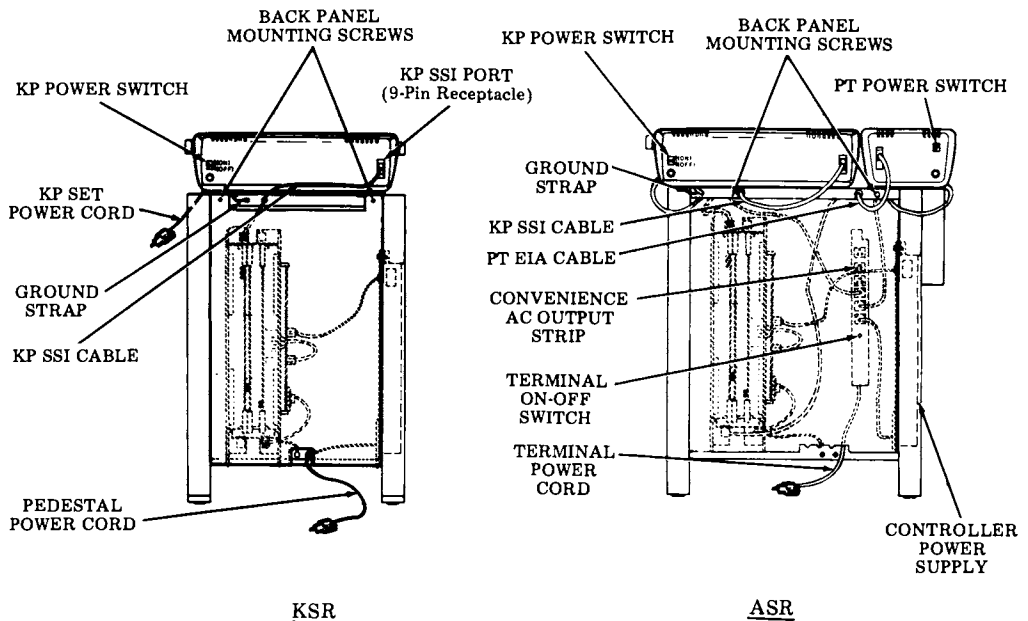

Fig. 4

- 3.12 Connect the Telex interface cable (customer provided) to the Telex interface card terminals 1 and 3 observing polarity. See Fig. 5. Route Telex interface cable through unused slot in pedestal base and replace back panel.



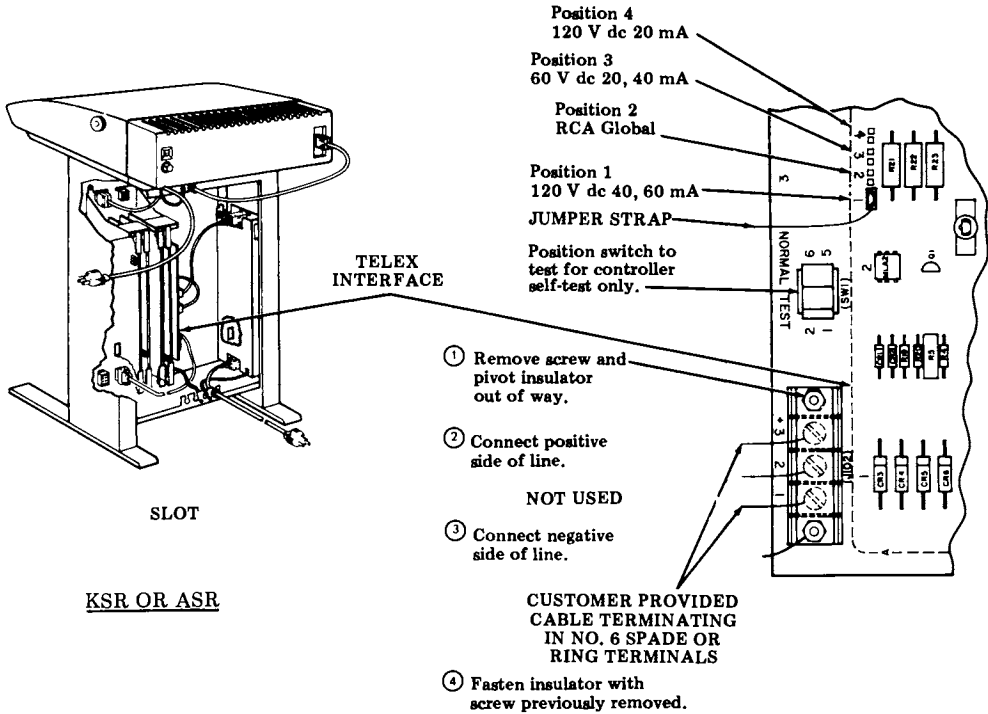

Fig. 5

3.13 ASR only — Position the PT unit PTR off local — normal switch to the normal position and position the CPS switch to the 30 position. See Fig. 6.

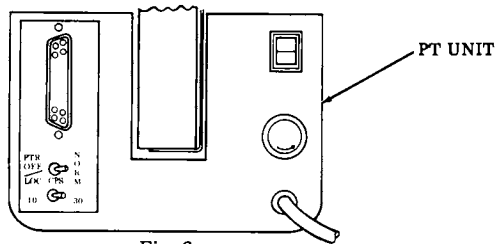



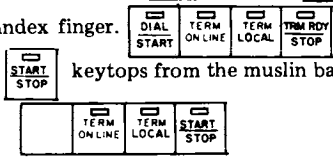

Fig. 6

3.14 RCA Global only — Remove  and the  keytops by pulling upward on keytop using the thumb and index finger.

Remove the blank and  keytops from the muslin bag attached to the terminal. Snap on the keytops in the positions shown.



## B. INSTALLATION AND REMOVAL (Contd)

### 3. INSTALLATION PROCEDURE (Pedestal Base) (Contd)

#### B. Assembly (Contd)

- 3.15 Position the teleprinter in the location specified by the customer. A minimum of 6 inches of space behind the teleprinter is required when the paper supply assembly is used to feed the paper. The ac power cord(s) extend 6 feet to the rear.
- 3.16 Stabilize the teleprinter by adjusting the left or right pedestal leg leveling screw. See Fig. 7.
- 3.17 Assemble the paper supply assembly as shown in Fig. 8. Pull the latches straight up and slide the paper supply assembly fully onto the mounting posts located at the rear of the bustle cover. Push down on the latches until they are secured over the mounting posts.

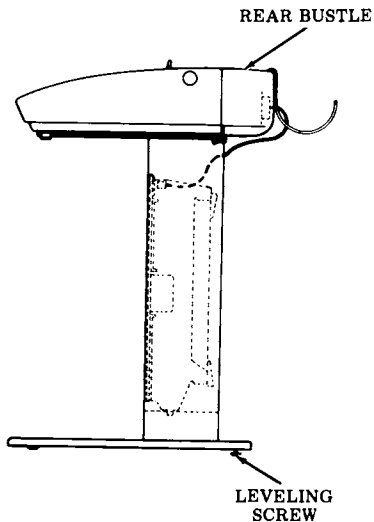

Fig. 7

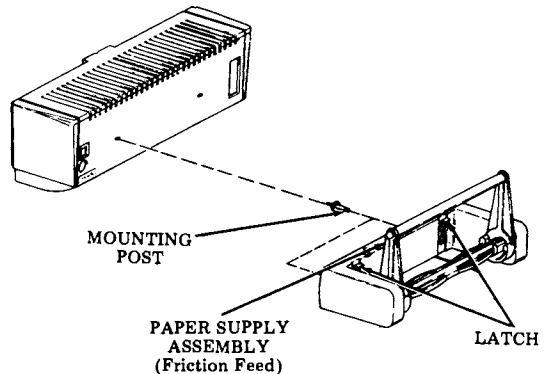

Fig. 8

#### C. Ribbon, Paper and Paper Tape (ASR) Installation

- 3.18 Install the ribbon, paper and paper tape (ASR). Refer to the How To Operate Manual 423.

#### D. Checkout Procedure

- 3.19 Connect the power cord(s) to a properly polarized and grounded source of 115 V ac power (50 or 60 Hz). Normally the power cords should be connected to unswitched outlets to avoid loss of stored data or call disconnects. Fuse protection should be time delayed and provide for a running current of 0.8 A for the KP set, 0.56 A for the pedestal and 1.0 A for the PT unit (ASR).
- 3.20 Certain user programmable options listed below should be reviewed to properly interface the 42 Buffered KSR or ASR Teleprinter with the system requirements. To enable the options, refer to the How To Operate Manual 423.

- 3.21 If any of the above options were changed from the state furnished condition enter the new value on the directory card, RECORD OF USER PROGRAMMABLE OPTIONS, section. (See Fig. 9.)
- 3.22 Perform the installation checkout procedures found in F. TESTING, Page 1-63.

E. Directory Card

- 3.23 Record the installed location of the station (floor, area, and phone, if any) location of extension phone if any, and the number to be called in case of trouble in the space provided on the slideout directory card (Fig. 9). Also mark the appropriate memory size.
- 3.24 Remove the directory card by pulling it out as far as it will go then, by holding card at edges, move it slightly to one side and pivot to clear the opposite latch. Fill in the information requested on the card. Replace the directory card.
- 3.25 Clean up the unpacking area, wipe off any finger prints on the set, and turn on 42 KSR or ASR teleprinter over to the subscriber.

MNEMONIC

DESCRIPTION

STATE FURNISHED

Speed                              The decimal value for the baud rate of the terminal. Allowed values: 0050, 0075, 0100, 0225 (leading zeros must be included)    0050

- 3.26 Provide the customer with the How To Operate Manual 423. Advise the customer to order spare ribbons, paper and paper tape (ASR) as soon as possible (quantities depending on expected usage).
- 3.27 Advise the customer of the "trouble number" location on the directory card.
- 3.28 Place the Manual 424, Installation and Routine Servicing in the shipping containers and retain.



DIRECTORY CARD

SERVICE RECORD	
INSTALLATION DATE: <u>5/75</u>	INSTALLED BY: <u>MVP</u>
PRINTER SN: <u>01234</u>	<input checked="" type="checkbox"/> INSTALLATION TEST PERFORMED
LOCATION: DATE: _____	<input type="checkbox"/> FURNISHED BY INSTALLATION ATTENDANT MANUAL
OTHER INFO: _____	<input type="checkbox"/> PAPER HOLDER
	<input type="checkbox"/> RIBBON
	<input type="checkbox"/> PAPER TAPE
RECORD OF INSTALLER PROGRAMMABLE OPTIONS	
Memory - <input type="checkbox"/> <u>01</u> - <input type="checkbox"/> <u>02</u>	Display - <input type="checkbox"/> <u>01</u> - <input type="checkbox"/> <u>02</u>
Line - _____	Area - _____
Other Non-Standard Options Installed (Number & Description)	
Memory Size <input checked="" type="checkbox"/> _____	
RECORD OF USER PROGRAMMABLE OPTIONS	
REFER TO HOW TO OPERATE MANUAL.	
Speed: <input type="checkbox"/> <u>00</u> - <input type="checkbox"/> <u>01</u> - <input type="checkbox"/> <u>02</u> - <input type="checkbox"/> <u>03</u>	Only: <input type="checkbox"/> <u>01</u> - <input type="checkbox"/> <u>02</u>
Line: <input type="checkbox"/> <u>01</u> - <input type="checkbox"/> <u>02</u> - <input type="checkbox"/> <u>03</u>	Area: <input type="checkbox"/> <u>00</u> - <input type="checkbox"/> <u>01</u> - <input type="checkbox"/> <u>02</u> - <input type="checkbox"/> <u>03</u>
Area: <input type="checkbox"/> <u>01</u> - <input type="checkbox"/> <u>02</u>	Ext: <input type="checkbox"/> <u>0000</u> - <input type="checkbox"/> <u>0001</u> - <input type="checkbox"/> <u>0002</u> - <input type="checkbox"/> <u>0003</u>
Line: <input type="checkbox"/> <u>000</u> - <input type="checkbox"/> <u>001</u> - <input type="checkbox"/> <u>002</u> - <input type="checkbox"/> <u>003</u>	Ext: <input type="checkbox"/> <u>000</u> - <input type="checkbox"/> <u>001</u> - <input type="checkbox"/> <u>002</u> - <input type="checkbox"/> <u>003</u>
Area: <input type="checkbox"/> <u>000</u> - <input type="checkbox"/> <u>001</u> - <input type="checkbox"/> <u>002</u> - <input type="checkbox"/> <u>003</u>	Ext: <input type="checkbox"/> <u>000</u> - <input type="checkbox"/> <u>001</u> - <input type="checkbox"/> <u>002</u> - <input type="checkbox"/> <u>003</u>
Ext: <input type="checkbox"/> <u>000</u> - <input type="checkbox"/> <u>001</u> - <input type="checkbox"/> <u>002</u> - <input type="checkbox"/> <u>003</u>	Ext: <input type="checkbox"/> <u>000</u> - <input type="checkbox"/> <u>001</u> - <input type="checkbox"/> <u>002</u> - <input type="checkbox"/> <u>003</u>
Area: <input type="checkbox"/> <u>000</u> - <input type="checkbox"/> <u>001</u> - <input type="checkbox"/> <u>002</u> - <input type="checkbox"/> <u>003</u>	Ext: <input type="checkbox"/> <u>000</u> - <input type="checkbox"/> <u>001</u> - <input type="checkbox"/> <u>002</u> - <input type="checkbox"/> <u>003</u>
Ext: <input type="checkbox"/> <u>000</u> - <input type="checkbox"/> <u>001</u> - <input type="checkbox"/> <u>002</u> - <input type="checkbox"/> <u>003</u>	Ext: <input type="checkbox"/> <u>000</u> - <input type="checkbox"/> <u>001</u> - <input type="checkbox"/> <u>002</u> - <input type="checkbox"/> <u>003</u>
Area: <input type="checkbox"/> <u>000</u> - <input type="checkbox"/> <u>001</u> - <input type="checkbox"/> <u>002</u> - <input type="checkbox"/> <u>003</u>	Ext: <input type="checkbox"/> <u>000</u> - <input type="checkbox"/> <u>001</u> - <input type="checkbox"/> <u>002</u> - <input type="checkbox"/> <u>003</u>
Ext: <input type="checkbox"/> <u>000</u> - <input type="checkbox"/> <u>001</u> - <input type="checkbox"/> <u>002</u> - <input type="checkbox"/> <u>003</u>	Ext: <input type="checkbox"/> <u>000</u> - <input type="checkbox"/> <u>001</u> - <input type="checkbox"/> <u>002</u> - <input type="checkbox"/> <u>003</u>

Bottom Side of Directory Card

FREQUENTLY CALLED NUMBERS		
NAME	AREA CODE	TEL NO.

INSTALLED LOCATION IN BUILDING: FLOOR 3 AREA/CODE PHONE 561-7896  
LOCATION OF EXTENSION PHONE, IF ANY: 0037 2/4

IF THE TERMINAL DOES NOT APPEAR TO BE WORKING PROPERLY, CONSULT THE "HOW TO OPERATE" MANUAL. IF YOU ARE IN CASE OF TROUBLE CALL: 368-1812

Top Side of Directory Card

Fig. 9

B. INSTALLATION AND REMOVAL (Contd)4. KSR STATION REMOVAL (Pedestal Based)

- 4.01 Reverse the procedures in 3. INSTALLATION PROCEDURE to remove the teleprinter from service.
- 4.02 Before repacking the teleprinter move the print head to the center of the printer and insert the packing detail removed in 3.05.
- 4.03 Tape the cover to the housing and tape the KP mounting clips in place as shown in Fig. 1.
- 4.04 Obtain the cartons and packing details retained in 3.06.
- 4.05 Remove the back panel of the pedestal.
- 4.06 Position a 28319PK corrugated detail between the side of the door opening and the controller frame. See Fig. 10.
- 4.07 Position a 28321PK corrugated detail between the controller frame and the 410705 circuit card. See Fig. 10.

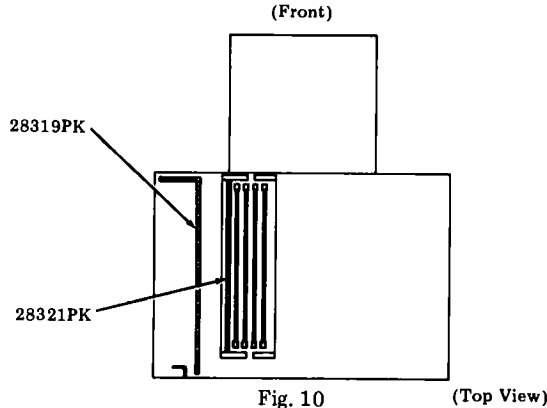

- 4.08 Position two 28376PK ethafoam details between the controller and the power supply. See Fig. 11.
- 4.09 Secure the ends of the controller together with a strip of tape. See Fig. 11.

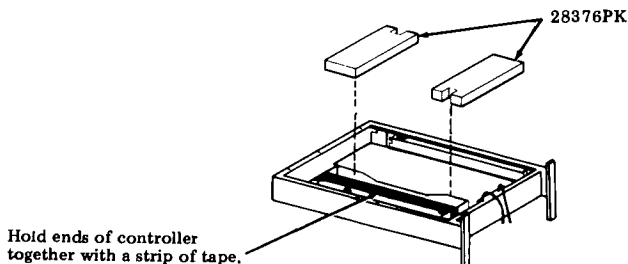

- 4.10 Replace back panel on the pedestal. Coil all the cables together and secure with tape.
- 4.11 Tape a copy of the unpacking instructions to the back panel. Use a copy of Fig. 12.

## B. INSTALLATION AND REMOVAL (Contd)

### 5. ASR STATION REMOVAL (Pedestal Base)

- 5.01 Reverse the procedures in 3. INSTALLATION PROCEDURE to remove the teleprinter from service.
- 5.02 Before repacking the teleprinter, move the print head to the center of the printer and insert the packing detail removed in 3.05.
- 5.03 Tape the KP set and PT unit as shown in Fig. 1. Make sure a piece of tape holds the chad chute in place. Tape the PT unit and KP mounting clips in place as shown in Fig. 1.
- 5.04 Obtain the cartons and packing details retained in 3.06.
- 5.05 Remove the back panel of the pedestal.
- 5.06 Secure the ends of the controller together with a strip of tape. See Fig. 15.

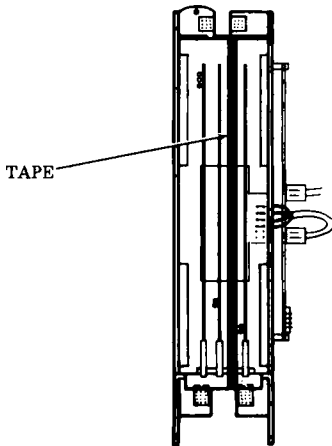

Fig. 15

- 5.07 Replace back panel on the pedestal.
- 5.08 Place a 28402PK pad over the rear of the paper supply assembly and fasten with two pieces of tape at the outer ends. See Fig. 16.
- 5.09 Secure the paper spindle to the paper supply assembly with a piece of tape. See Fig. 16.

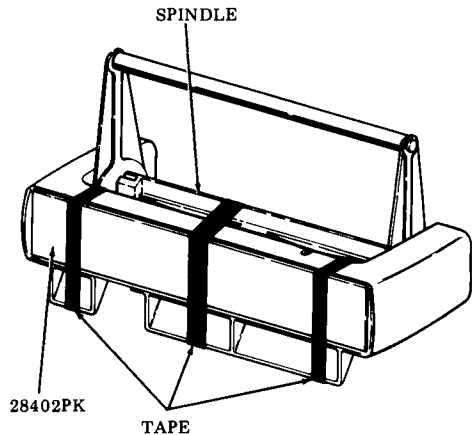

Fig. 16

- 5.10 Coil the ac power cable and secure to the rear panel with tape.
- 5.11 Position a 28398PK Detail "A" against the left side of the PT unit. See Fig. 17. Position a 28398PK Detail "B" against the left rear of the KP bustle. Tape Detail "A" and "B" together.
- 5.12 Place a 28401PK Detail "A" on the right side of the KP set. See Fig. 17.

## B. INSTALLATION AND REMOVAL (Contd)

### 6. INSTALLATION PROCEDURE (Tabletop)

#### A. Unpacking

- 6.01 Select an area to unpack the carton so that damage to the teleprinter will not occur.
- 6.02 When unpacking, be sure to wear approved safety glasses.

*Caution: To avoid condensation on the electrical components, the teleprinter should be allowed to assume room temperature before unpacking, for example, when brought into a warm humid room from outside subzero temperatures.*

- 6.03 The Tabletop 42 Buffered KSR Teleprinter is furnished in a single carton.
- 6.04 For unpacking of the PT unit (ASR) refer to Service Manual 422.
- 6.05 For unpacking of the 403103 or 420301 line interface unit (if present) refer to Specification 50998S or 51048S respectively.
- 6.06 Unpack the carton referring to instructions on the container. Remove tape securing the cover and paper separator to the housing (Fig. 18).

*Note;* Observe all "Caution" notes printed on the carton.

- 6.07 Depress the cover locking tabs on the lower front of the cabinet and lift the cover. Remove the packing detail securing the print head and the ribbon in place (Fig. 18).
- 6.08 The containers and other packing details should be retained and reused by field locations to facilitate movement of stations.
- 6.09 Verify that the following items are included in the box:
- 1 — Teleprinter Set
  - 1 — Ribbon
  - 1 — Manual Installation and Routine Servicing 455 or 567
  - 1 — Manual, How To Operate 454
  - or
  - 3 — Manuals, How To Operate 564, 565 or 566
  - 1 — Paper Supply Assembly (Friction Feed)

*Note:* 8-1/2 inch wide by 5 inch diameter rolls (Friction Feed) must be obtained locally or ordered separately. Paper tape for the PT unit (ASR) must be 11/16-inch wide oiled paper furnished in eight inch maximum diameter rolls with two inch diameter spindle hole. The tape should be 0.004 inch thick, 50 pound basic paper and must meet ANSI Standard X3.29. Refer to the How To Operate Manual.

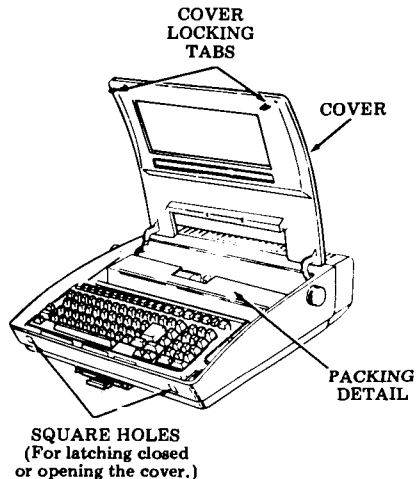
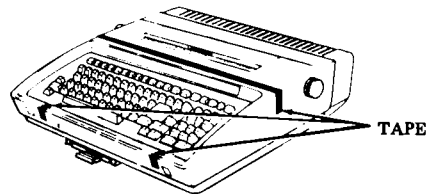

Fig. 18—Packing Detail

## B. Assembly

- 6.10 Assemble the paper supply assembly as shown in Fig. 19. Pull the latches straight up and slide the paper supply assembly fully onto the mounting posts located at the rear of the bustle cover. Push down on the latches until they are secured over the mounting posts.

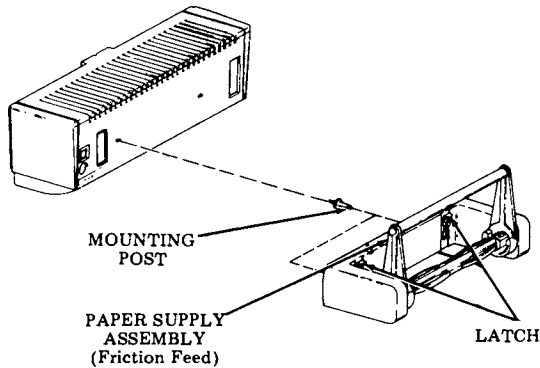

Fig. 19

- 6.11 ASR only — Connect the 430757 cable to the KSR and PT unit. If the PT unit is to be mounted flush against the KSR, remove the platen knob by pulling straight off.

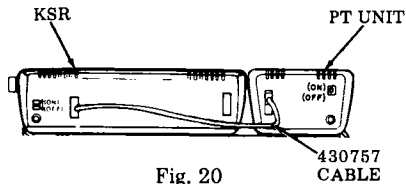

Fig. 20

- 6.12 Line interface (if present) — Connect the 407494 cable to the KSR and to the 403103 or 420301 line interface or connect the 454678 cable to the line.

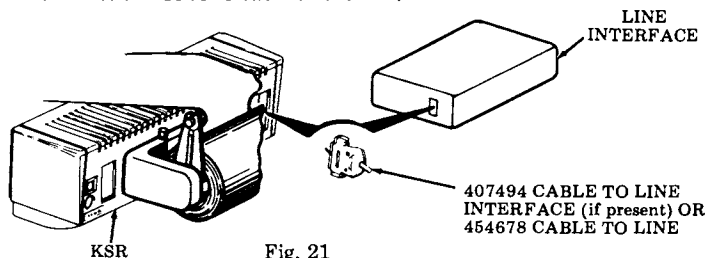

Fig. 21

- 6.13 Position the teleprinter on a table, suitable stand or pedestal, in the location specified by the customer. A minimum of 6 inches of space behind the terminal is required when the paper supply assembly and a roll of paper are assembled. See Page 1-30 for EIA interface lead designations at rear of the teleprinter.

B. INSTALLATION AND REMOVAL (Contd)

6. INSTALLATION PROCEDURE (Tabletop) (Contd)

EIA Line Interface Signals -- 407494 Cable

The EIA leads that appear at the interface (EIA designations in parenthesis) are defined below in terms of common designations. Solid arrows indicate direction of data flow or control.

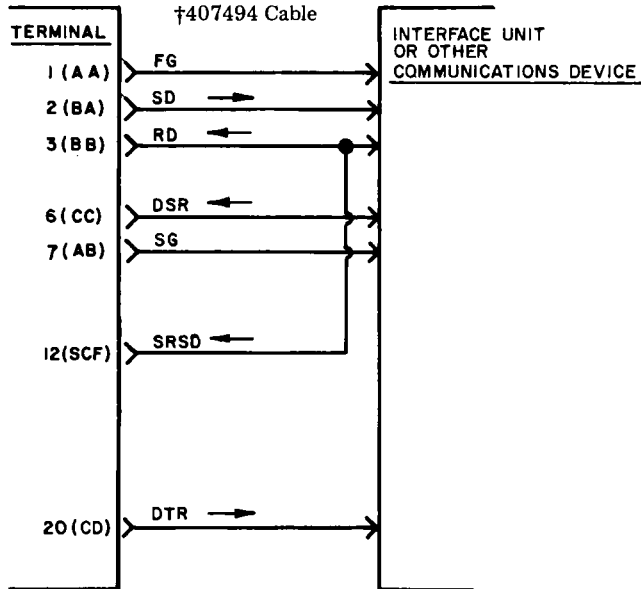

Electrical Characteristics

EIA (RS232) Interface	Electrical Characteristics	
	From 43	To 43
Space or On	+3 to +25 V dc	+3 to +25 V dc
Mark or Off	-3 to -25 V dc	-3 to -25 V dc

- FG — Frame Ground
- SD — Send Data. Mark in all modes varies when on-line and sending data.
- RD — Receive Data. In state supplied by Data Set.
- DSR — Data Set Ready. DSR and CD on puts teleprinter in Term On-Line mode if DTR is on. If DSR is off teleprinter switches from Term On-Line to Term Ready.
- SG — Signal Ground.
- SRSD — Secondary Receive Line Signal Detector. Connected to Received Data.
- DTR — Data Terminal Ready. Off if teleprinter in Term Local, on if teleprinter in Term Ready or Term

On-Line mode. Receipt of Dscnt (Option) character or depression of Term Ready if in Term On-Line mode turns off DTR for 50 ms. Alarm condition turns off DTR if in Term Ready mode. Alarm does not turn off DTR if in Term On-Line mode. Off when Controller Self-Test is entered.

† If the interface unit or other communications device is more than seven feet from the teleprinter, one of the following cables may be coupled to the 407494 cable. The total distance between the teleprinter and interface unit or communications device should not exceed 50 cable feet.

Cable	Part No.
3 foot length	430569
7 foot length	408065
12 foot length	408066
25 foot length	408067
50 foot length	*408068

Note: The above cables, if required, must be ordered separately.

\* Must be modified to replace the 407494.



EIA Line Interface Signals — 454678 Cable

The EIA leads that appear at the interface (EIA designations in parenthesis) are defined below in terms of common designations. Solid arrows indicate direction of data flow or control.

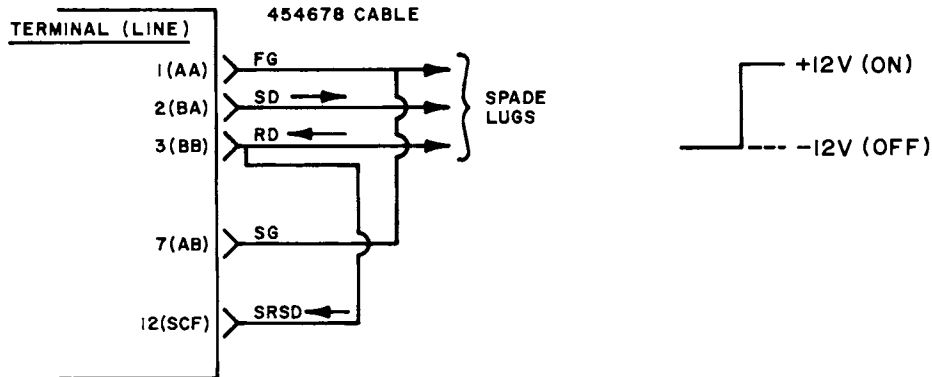

## Electrical Characteristics

EIA (RS232) Interface	Electrical Characteristics	
	From 43	To 43
State 0 (space) On	+5 to +15 V dc	+5 to +15 V dc
State 1 (mark) Off	-5 to -15 V dc	-5 to -15 V dc

- FG — Frame Ground
- SD — Send Data. +12 volts indicates a space or break. -12 volts indicates a mark.
- RD — Receive Data. +12 volts indicates a space or break. -12 volts indicates a mark.
- RTS — Request To Send. On if character is ready for transmission and DTR and DSR are on.
- SG — Signal Ground.
- SRSD — Secondary Receive Line Signal Detector. Connected to Receive Data.

B. INSTALLATION AND REMOVAL (Contd)

6. INSTALLATION PROCEDURE (Tabletop) (Contd)

C. Ribbon, Paper and Paper Tape (ASR) Installation

6.14 Install the ribbon, paper and paper tape (ASR). Refer to the How To Operate Manual.

D. Checkout Procedure

6.15 Connect the 403103 or 420301 line interface (if present) and teleprinter power cords to a properly polarized and grounded source of 115 (or 230) Vac power (50 or 60 Hz). Normally the power cords should be connected to unswitched outlets to avoid loss of stored data or call disconnects. Fuse protection should be time delayed and provide for a running current of 0.8A for the teleprinter and 1.0A for the PT unit (ASR). Refer to Specifications 50998S or 51036S for the running current of the 403103 or 420101 line interface, respectively.

6.16 Certain user programmable options listed below should be reviewed to properly interface the 42 Buffered KSR or ASR Teleprinter with the system requirements. To enable the the options, refer to the appropriate How To Operate Manual.

6.17 If any of the options changed from the furnished condition, enter the new values in the RECORD OF USER PROGRAMMABLE OPTIONS section of the directory card (see Fig. 22) or print out a copy of the options for future reference.

6.18 Perform the teleprinter installation check-out procedures found in F. TESTING, Page 1-63.

E. Directory Card

6.19 Record the installed location of the station (floor, area, and phone, if any), location of extension phone if any, and the number to be called in case of trouble in the space provided on the slideout directory card (Fig. 22).

6.20 To remove the directory card, pull it out as far as it will go, then by holding card at edges, move it slightly to one side and pivot to clear the opposite latch. Fill in the information requested on the card. Replace the directory card.

6.21 Clear up the unpacking area, wipe off any finger prints on the set, and turn the 42 Teleprinter over to the subscriber.

<u>MNEMONIC</u>	<u>DESCRIPTION</u>	<u>STATE FURNISHED</u>
Speed	The decimal value for the baud rate of the teleprinter. Allowed values: 0045, 0050, 0075, 0100, 0200, or 0225 (leading zeros must be included).	0050
Procl	Protocol. Allowed values: 1, 2, 3 or 4.	1



C. ENGINEERING OPTIONS

<u>CONTENTS</u>	<u>PAGE</u>
1. GENERAL .....	1-36
OPTION SWITCHES.....	1-36
2. TOOLS REQUIRED.....	1-36
3. ACTIVATING OPTIONS .....	1-37
4. INSTALLER PROGRAMMABLE OPTIONS (Pedestal Based) .....	1-43
5. INSTALLER PROGRAMMABLE OPTIONS (Tabletop) .....	1-43
6. RECORDING OPTION CHANGES .....	1-43
7. OPTION CHECKOUT.....	1-44

1. GENERAL

1.01 This part provides information on engineering options for the 42 Buffered KSR or ASR Teleprinter.

1.02 The engineering options can be used to satisfy requirements using switches or straps, located on the logic card mounted on the bottom of the printer frame, in the PT unit (ASR) or in the pedestal based controller.

1.03 The option is numbered for field identification and record keeping purposes.

1.04 The keyboard circuitry can be damaged by static discharge. The 346392 static discharge ground strap is available for use by service personnel.

1.05 When ordering replaceable components, unless otherwise specified, prefix each part number with the letters "TP" (ie, TP410425).

1.06 For additional servicing information refer to D. TROUBLESHOOTING, Page 1-45.

OPTION SWITCHES

1.07 Different styles of option selecting switches may be present on the logic card or in the PT unit (ASR). On toggle or slide type

switches, options are activated by positioning the toggle or slide toward the positions indicated in Fig. 1.

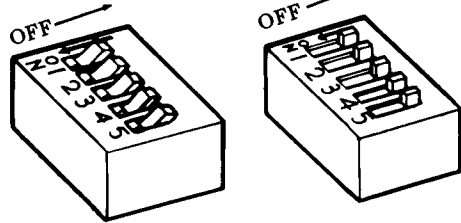

Toggle Style

Slide Style

(Toggles and Slides shown in OFF position.)

Fig. 1--Option Switches

1.08 The options on the logic circuit card or in the PT unit (ASR) are factory optioned and should not be changed unless the local engineering requirements specify incorporating a nonstandard option (Fig. 2).

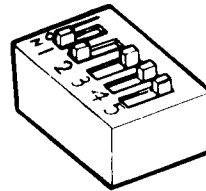

Fig. 2--Standard Switch Positions

2. TOOLS REQUIRED

2.01 The following tools will be required to enable the engineering options. These items should normally be present in standard maintenance tool kits.

Wrench, Open end - 3/16" and 1/4"	129534
Screwdriver - 1/4", 6" Blade	100982
Static Discharge Strap	346392
Wrench, Hex Key 0.062"	124682

### 3. ACTIVATING OPTIONS

3.01 To activate Option 431 turn off ac power to the teleprinter.

- ① Depress the two locking tabs on the lower front of the cabinet and open the cover.

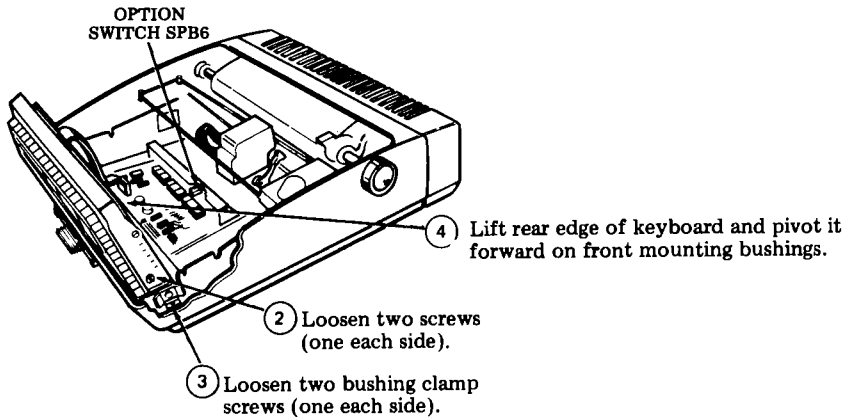

- ⑦ Slowly rotate cover rearward until extension on cover aligns with locking hole in side frame. Apply slight leftward pressure until the extension engages the hole in the side frame, locking the cover into position.

- ⑧ Reverse steps to reposition keyboard.

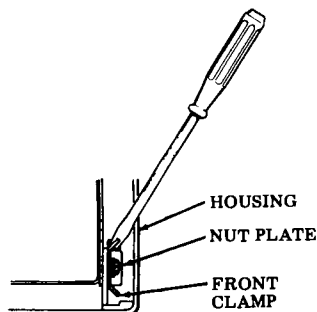
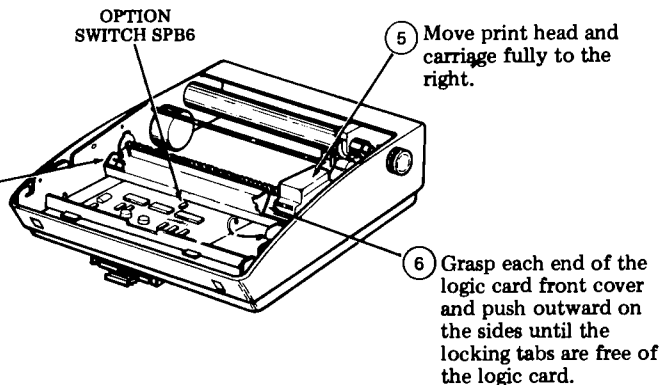

*Note:* In repositioning keyboard, perform the KEYBOARD TO COVER ALIGNMENT adjustment. See Page 5-2.

Fig. 3—Option Switch Access

3.02 Locate the option switch pack SPB6 (Fig. 3) on the logic card and activate the option switches in Fig. 9.

3.03 Reinstall the logic card front cover and keyboard, tighten the screws loosened in 3.01 and close the cabinet cover.

C. ENGINEERING OPTIONS (Contd)

3. ACTIVATING OPTIONS (Contd)

3.04 To activate Options 453, 454 or 455, turn off power to the PT unit.

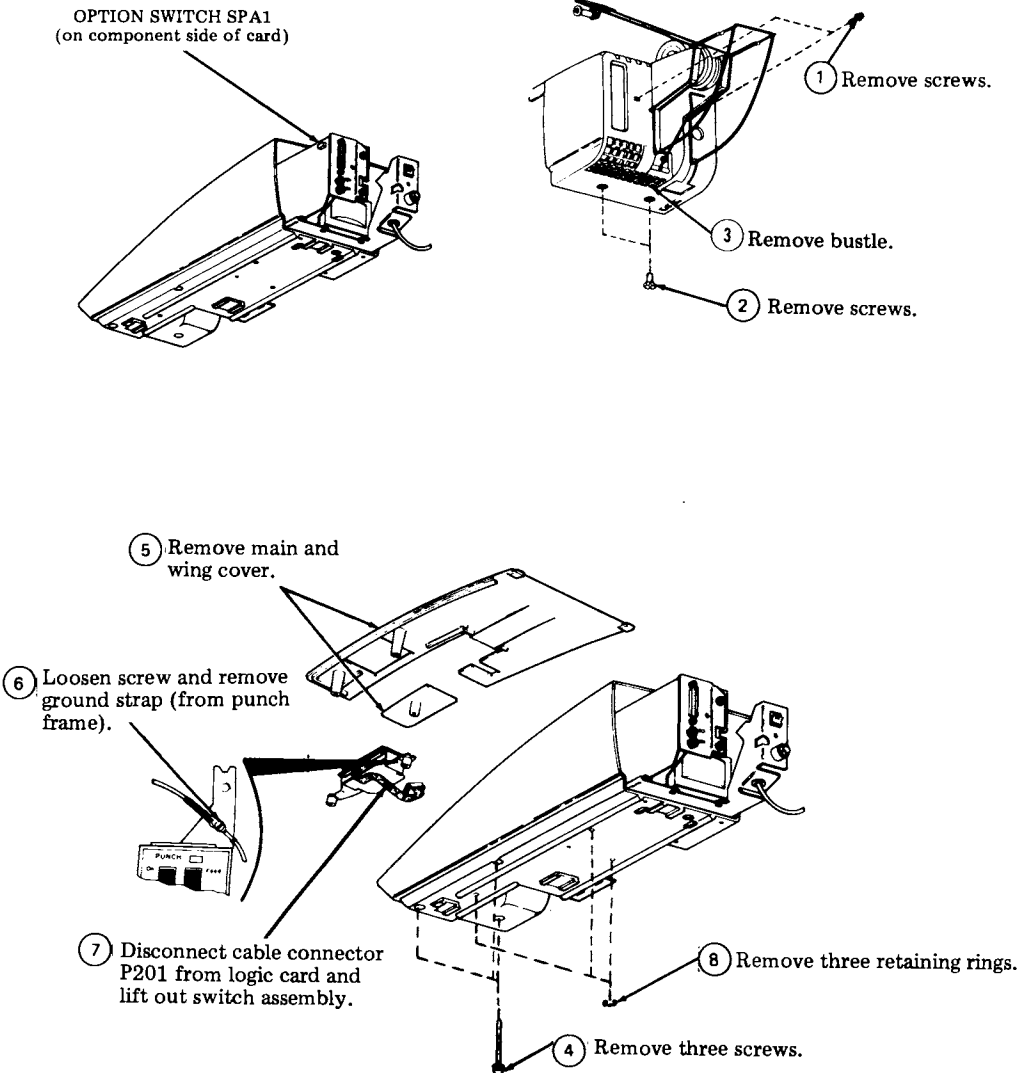
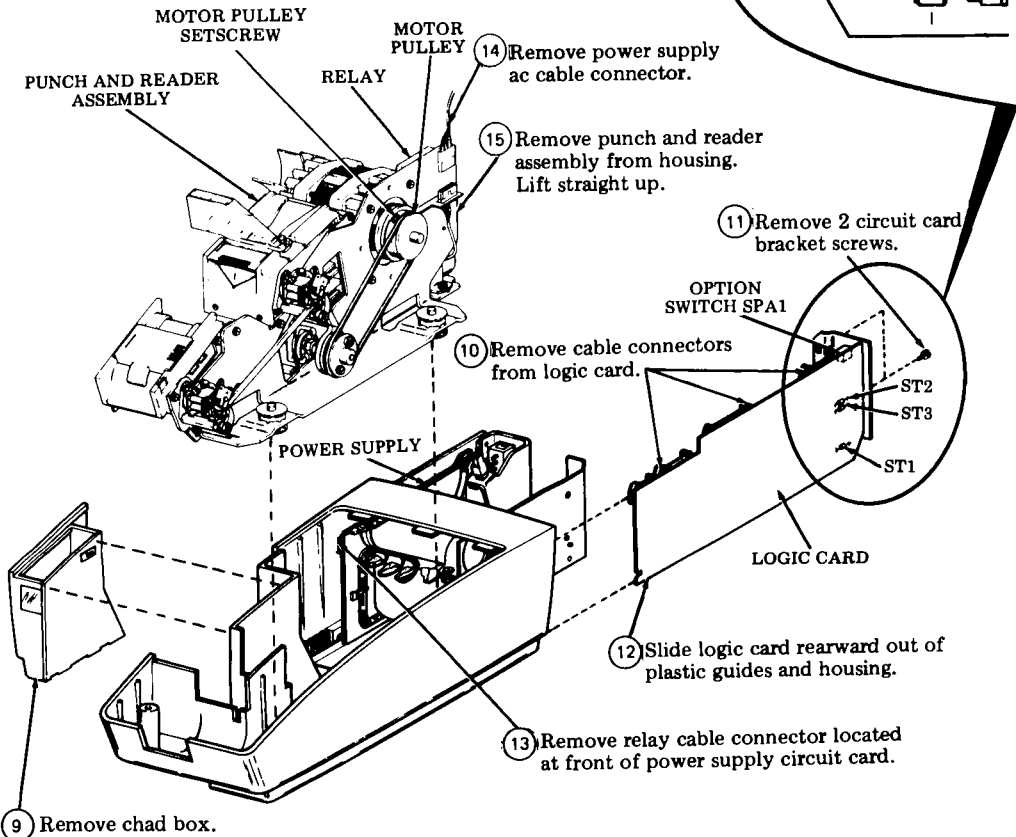
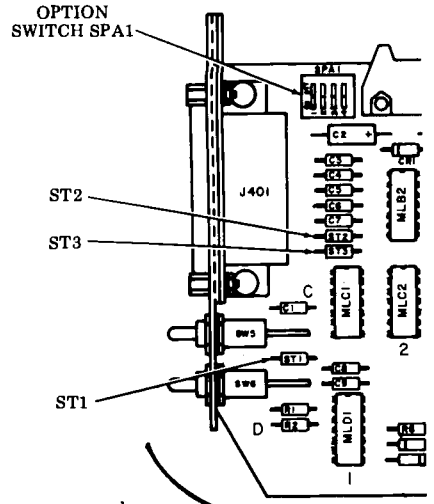

Fig. 4

3.05 Option 453 and 454 — Locate option switch SPA1 and straps ST1, ST2, and ST3 (Fig. 5). Refer to Fig. 9 and set switches and add or remove straps as required.

3.06 Option 455 — Locate the motor pulley and motor pulley setscrew (Fig. 5). Loosen the motor pulley setscrew and position motor pulley as required per Fig. 9.



9 Remove chad box.

Fig. 5

C. ENGINEERING OPTIONS (Contd)

3. ACTIVATING OPTIONS (Contd)

3.07 To activate Option 456 turn off ac power to the controller.

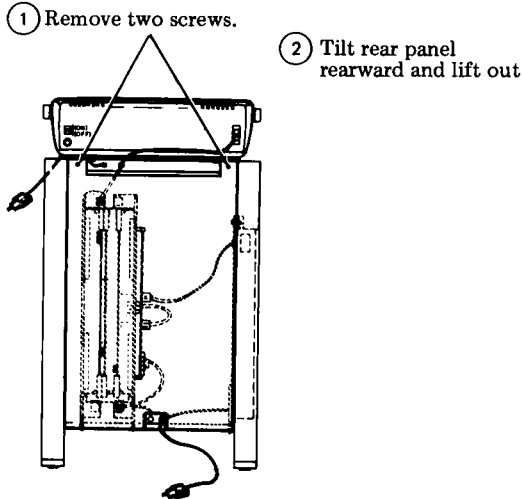

KSR OR ASR

Fig. 6

3.08 Locate the jumper strap (Fig. 7) on the Telex interface card and place it in the applicable position (Fig. 7 and Fig. 9).

3.09 Replace the rear panel removed in 3.07.

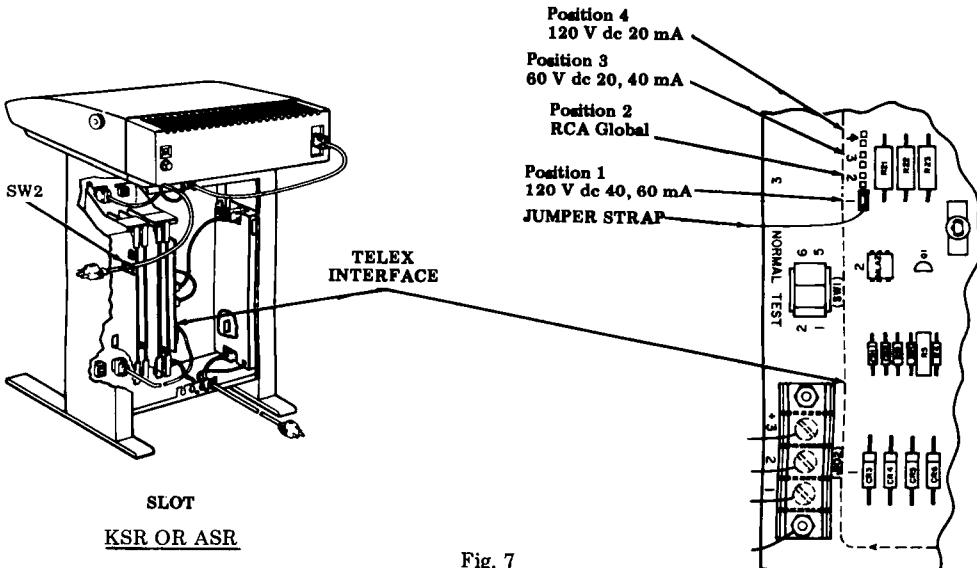

Fig. 7



3.10 To activate Option 467 (for 4240BAA or BAB) or Option 477 (for 4240BAC or BAD) — Turn off power to the teleprinter. Reach through the 21st slot from the left in the bustle and position switches as required. See Fig. 9.

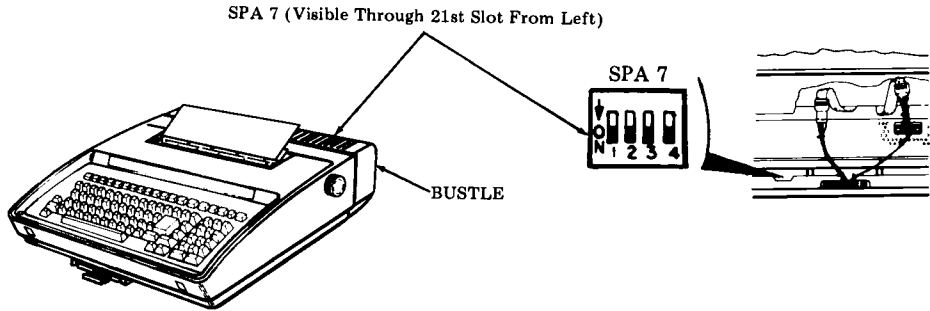

Fig. 8

OPTION NO.	OPTION SUFFIX AND CONDITIONS	OPTION DEFINITION	SWITCH NUMBERS					SWITCH PACK OR STRAP LOCATION ON CIRCUIT CARD
			SPB6					
XXX			1	2	3	4	5	
a.								
b.								

KSR OR ASR SET OPTIONS (LOGIC CARD)

431.	Type Font Arrangement	SPB6					
		1	2	3	4	5	
a.	Narrow Numeric 0 and Wide Alpha 0.	●	●	-	-	-	*
b.	Slash Numeric 0 and Wide Alpha 0.	○	●	-	-	-	
c.	Slash Alpha 0 and Wide Numeric 0.	○	○	-	-	-	
Switches Must be Set as Shown.		-	-	○	○	○	*

PT UNIT (ASR) OPTIONS

453.	Function of "Copy" Switch in PTR OFF/LOC Position.	SPA1				ST1	
		1	2	3	4		
a.	Printer Off Operation	-	-	-	○	Strap In	*
b.	Local Operation (TTL Pin 17 Open)	-	-	-	●	Strap Out	
c.	Local Operation (TTL Pin 17 ground)	-	-	-	●	Strap In	
d.	Normal	-	-	-	○	Strap Out	
Switches Must be Set as Shown.		○	●	○			

Fig. 9—Option Setting

## C. ENGINEERING OPTIONS (Contd)

## 3. ACTIVATING OPTIONS (Contd)

## PT UNIT (ASR) OPTIONS (Contd)

454.	Clear to Send Select	ST2	ST3
a.	Clear to Send Controls.	Strap In	Strap Removed *
b.	Device Control Controls	Strap Removed	Strap In
c.	Device Control and Clear to Send Controls.	Strap In	Strap In

455.	50/60 Hz Operation	Motor Pulley <sup>s</sup>	
		Small Side	Large Side
a.	60 Hz Operation	Outside	Inside †
b.	50 Hz Operation	Inside	Outside

## PEDESTAL BASED CONTROLLER OPTIONS (Telex Interface Card)

456.	Line Voltage and Current Interface	Strap S1 Position			
		1	2	3	4
a.	120 V dc 40, 60 mA	X			
b.	Idle — RCA Global only		X		
c.	60 V dc 20, 40 mA			X	
d.	120 V dc 20 mA				X

## TABLETOP CONTROLLER OPTION (4240BAA and BAB)

467.	Keyboard Option Access	SPA7			
		1	2	3	4
a.	Auto 1 through DbLF	—	—	○	○
b.	Auto 1 through EBWrn	—	—	○	●
c.	All Options	●	●	●	●

## TABLETOP CONTROLLER OPTION (4240BAC and BAD)

477.	Keyboard Option Access	SPA7			
		1	2	3	4
a.	Auto 1 through CALrm	—	—	○	○
b.	Auto 1 through EBWrn	—	—	○	●
c.	All Options	●	●	●	●

● Indicates toggle or slide position to ON.

○ Indicates toggle or slide position to OFF.

— Position of switch does not affect option.

x Position of strap. Must conform to line voltage and current requirements.

† Factory furnished state of option.

\* Factory furnished state of option — required for this application.

<sup>s</sup> Verify motor pulley is aligned with reader pulley and there is some clearance between the motor pulley and the ac power connector bracket.

Fig. 9—Option Setting (Contd)

**4. INSTALLER PROGRAMMABLE OPTIONS**  
**(Pedestal Based)**

4.01 The options shown below are not programmable by the user except by specific request to the installer. To change these options, SW2 on the 410705 circuit card must be depressed and rotated 1/4-turn clockwise. See Fig. 7. Once SW2 is depressed, the options shown below will be appended to the end of the user programmable option list. To change the value of these options, see OPTIONS in the How To Operate Manual 423.

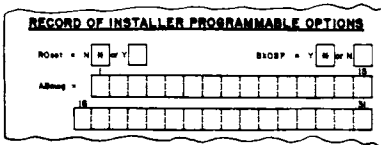

Fig. 10—Directory Card

Note: Options may revert back to the default values shown in the How To Operate Manual if power to the controller has been off for 17 days.

4.02 After the new values have been loaded, rotate SW2 on the 410705 circuit card 1/4-turn counterclockwise unless access to these options is specifically requested by the user. Rotating SW2 1/4-turn counterclockwise and the switch releasing to the out position, removes the above options from the user programmable option list and makes it inaccessible to changes by the user.

**5. INSTALLER PROGRAMMABLE OPTIONS**  
**(Tabletop)**

5.01 All teleprinters are factory furnished with all controller options keyboard accessible (ie, 467C or 477C). To change the value of these options or to determine which operator programmable options may be protected (not user programmable), see OPTION information in the How To Operate manual.

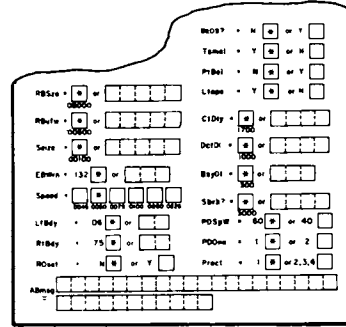

Fig. 11—Directory Card

Note: Options may revert back to the default values shown in the How To Operate Manual if power to the terminal has been off for 17 days.

5.02 After the new values have been loaded, enable the options specifically requested by the user. Enabling Option 467a. removes the option list and makes it inaccessible to changes by the user (4240BAA or BAB).

**6. RECORDING OPTION CHANGES**

6.01 Remove the directory card by pulling it out as far as it will go then, by holding card at edges, move it slightly to one side and pivot to clear the opposite latch.

6.02 Record the nonstandard option(s) incorporated in the terminal on the directory card. See Fig. 12 for the pedestal based directory card or Fig. 13 for the 4240BAA or BAB tabletop directory card. A copy of the 4240BAC or BAD option list may be printed out for future references.

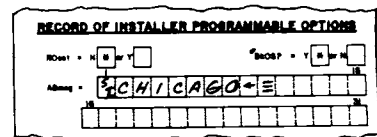
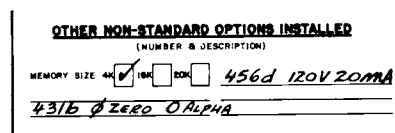

Fig. 12—Directory Card (Pedestal Based)

C. ENGINEERING OPTIONS (Contd)

6. RECORDING OPTION CHANGES (Contd)

**SWITCH PROGRAMMABLE OPTIONS**

TYPE FRONT SWITCHES  
 SWITCHES AS FACTORY  
 OPTIMIZED  
 SWITCHES 1 & 2  
 MUST REMAIN ON  
 SWITCH ACCESS  
 SWITCHES SWOWN A  
 FACTORY OPTIONED

4556. 50Hz

**KEYBOARD PROGRAMMABLE OPTIONS**

Auto 1  
 2  
 3  
 4  
 5  
 6  
 7  
 8  
 9

M/TAB ← 10 or       BODY ← N or   
 ← Key 7 ←  or       T/Tab ←  or   
 → Key 7 →  or       P/Bal ←  or   
 DEL ←  or       L/Tab ←  or   
 M/Ser ←  or       C/DY ←  or   
 M/Bal ←  or       D/ID ←  or   
 Ser ←  or       B/PO ←  or   
 E/Bal ← 132 or       S/Br ←  or   
 Speed ←  or       P/Sp ← 60 or 40 or   
 L/Bal ←  or       P/On ← 1 or 2 or   
 R/Bal ← 75 or       Pres ← 1 or 2, 3, 4 or   
 M/Out ←  or       Pres ← 1 or 2, 3, 4 or

SCANNING

Fig. 13—Directory Card  
(4240BAA or BAB Tabletop)

6.03 Reinstall the directory card “frequently called numbers” side up. Turn on ac power to the teleprinter.

6.04 Perform the option checkout procedure for Option 431 only to verify proper operation of the nonstandard option installed. Refer to 7. OPTION CHECKOUT for checkout procedure.

6.05 The checkout procedure in 7. OPTION CHECKOUT provides information for checking nonstandard options only. Refer to Page 1-63 teleprinter testing procedures for standard options.

7. OPTION CHECKOUT

7.01 Perform the following procedure.

PROCEDURE	RESPONSE	OPTION
Depress <input type="checkbox"/> (Alpha) key.	O Ø	431b. 431c.
Depress <input type="checkbox"/> (Zero) key.	Ø O	431b. 431c.

D. TROUBLESHOOTING

	<u>CONTENTS</u>	<u>PAGE</u>
1.	GENERAL .....	1-45
2.	TROUBLESHOOTING FLOW DIAGRAM .....	1-46
3.	TROUBLESHOOTING GUIDE (Pedestal Based) .....	1-47
4.	TROUBLE SHOOTING GUIDE (Tabletop).....	1-52

1. GENERAL

1.01 This part provides troubleshooting information for the 42 Buffered KSR and ASR Teleprinters.

1.02 Troubleshooting is based on isolation of troubles to major components and the correction of troubles by replacement of these components or by reference to the component troubleshooting paragraphs in the related component sections of the manual. If troubleshooting indicates a trouble in the PT (paper tape) unit, refer to Service Manual 422.

*Note:* When ordering replaceable components, unless otherwise specified, prefix each part number with the letters "TP" (ie, TP410625).

- 1.03 Component troubleshooting parts are:
- Page 2-1     42 Printer
  - Page 3-1     42 Buffered Keyboard
  - Page 4-2     42 Buffered Controller with  
                  Power Supply (Pedestal Based)
  - Page 4-4     Controller Card Assembly  
                  (Tabletop)

1.04 Trouble isolation provided in this section is intended for use by the craftsperson at the station location. Troubles may occur either during an installation, a routine maintenance visit or as the result of a customer trouble report.

1.05 Trouble isolation for the attendant is provided in the How To Operate Manual 423, 454 or 566.

1.06 To facilitate trouble correction, the recommended maintenance spares as listed on Page 1-112 should be available. In addition, parts for the repair of components as listed on Page 2-36, Page 3-12 and Page 5-3 for the printer, keyboard and paper handling and enclosures should be available.

1.07 For component access, refer to the Disassembly/Reassembly, Page 1-92 and Engineering Options, Page 1-36.

1.08 For location and identification of station components, refer to Page 1-112.

1.09 When replacement of the print head, logic card or keyboard corrects the trouble, additional checks should be made to isolate and possibly correct the trouble without returning for repair.

- On the print head — check cable continuity.
- On the logic card — check SSI Interface and power supply cables or fuse.
- On the keyboard — check the cable and key-switches per keyboard troubleshooting.

1.10 When replacement of a componen. does not correct the trouble, the original component should be reinstalled before going to the next step of the trouble analysis. If there are no more directives provided, go to the last question.

1.11 Circuitry used in the keyboard can be damaged by high static voltage discharge. The 346392 wrist strap is available to ground service personnel.

1.12 When returned to the Teletype Product Service Center for repair, the teleprinter or components should be packed in the container in which the replacement is received. This includes the conductive (black) plastic bag used with the keyboard for static protection.

1.13 Pedestal Based components returnable for repair and referred to in this section for replacement are:

- 430850 Print Head
- 43K202/GAC Operator Console
- 430700 Power Supply
- 410745 Logic Card
- 410746 SSI Card
- 410705 IXL/Eprom Card
- 410294 AUX CIU/RAM Card
- 410291 CIU/SSI Card
- 430770 Power Supply
- 410297 16K RAM CARD
- 410756 Telex Interface Card

D. TROUBLESHOOTING (Contd)

1. GENERAL (Contd)

1.14 Tabletop components returnable for repair referred to in this section for replacement are:

- 430850 Print Head
- 43K202/GAD Keyboard
- 430780 Power Supply
- 430760 Power Supply
- 410745 Logic Card
- 410785 Logic Card
- 411904 Controller Card Assembly (16K)
- 411959 Program Card

1.15 Before disconnecting cables or replacing circuit cards, turn off ac power. Make

certain power cords are connected to a properly polarized and grounded ac outlet.

1.16 Refer to 2. TROUBLESHOOTING DIAGRAM for the intended flow of troubleshooting.

1.17 Trouble analysis is presented in the form of a "20 Questions" routine in 3. TROUBLESHOOTING GUIDE. The guide, with questions and yes or no columns, should be used always starting with the first question and proceeding according to the "yes" or "no" directive.

2. TROUBLESHOOTING FLOW DIAGRAM

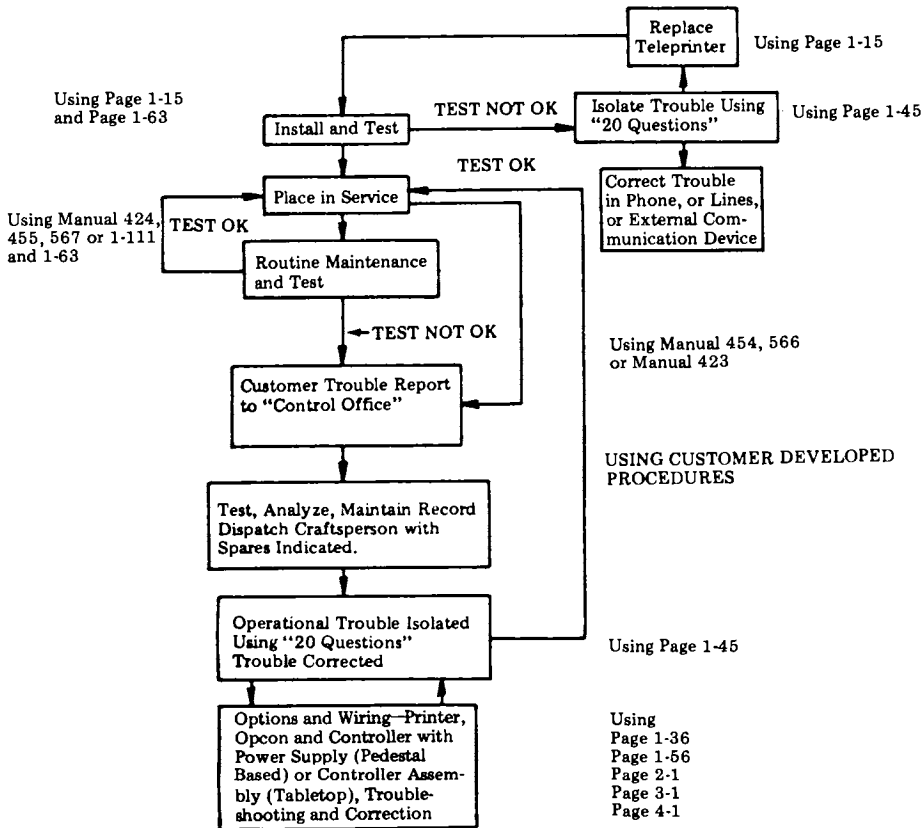

3. TROUBLESHOOTING GUIDE (Pedestal Based)

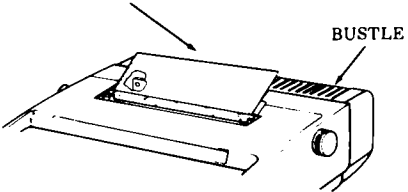
QUESTION	YES	NO
<p>1. Are any indicators on keyboard lit? (Power available, ac and SSI cords plugged in, KP set and PT unit (ASR) power on, and cover closed.)</p>	Go to 2.	Go to 1a.
<p>1a. Is there any indication of power in the set? (Keyboard lamps flash when KP power is turned on and off, print head indexes to the left, RED lamp on KP power supply lit, etc.)</p>	Go to 1c.	<p>ASR — Check power cable connections to ac distribution strip. AC distribution on-off switch must be on.</p> <p>With power off, check KP set F1 fuse. (See Page 1-60.)</p> <p>If fuse is OK, go to 1c.</p> <p>Replace fuse blown. Go to 1b.</p>
<p>1b. Do any indicators now light when power is turned on?</p>	Original trouble is corrected.	Replace KP Power Supply. Replace rear frame assembly.
<p>1c. Is RED lamp on KP power supply lit?</p> <p>(Visible through slot in bustle, 6th slot from left.)</p> 	<p>Check SSI cable from KP to controller.</p> <p>Check seating of KP power supply output cable.</p> <p>Check cable from logic card to SSI card.</p> <p>Check keyboard cable plug.</p> <p>Perform Controller Self-Test — See Controller Troubleshooting, Page 4-1.</p> <p>Perform Keyboard Self-Test — See How To Operate Manual 423.</p> <p>Replace SSI card.</p> <p>Replace Logic card.</p> <p>Replace CIU/SSI card.</p>	Disconnect power supply cable and go to 1d.
<p>1d. Does RED lamp on KP power supply now light?</p>	<p>Unplug SSI card cable, keyboard and all printer cables (7).</p> <p>Reconnect KP power supply cable and go to 1c.</p>	<p>Check Fuse (F2) on power supply. Replace if blown.</p> <p>Replace power supply.</p> <p>Replace rear frame assembly.</p>

## D. TROUBLESHOOTING (Contd)

## 3. TROUBLESHOOTING GUIDE (Pedestal Based) (Contd)

QUESTION	YES	NO
1e. Does RED lamp on power supply still light?	Go to 1f.	Replace logic card.
1f. Does RED lamp on power supply go out after the SSI card, keyboard and printer cables are reconnected one at a time?	Replace the SSI card, keyboard or the printer component (refer to Printer Troubleshooting, Page 2-1) that caused lamp to extinguish.	Intermittent short. Check for foreign objects between circuit lands or terminals.
2. Does set continually go to options prep mode when powering up.	Perform Controller Self-Test — See Controller Troubleshooting, Page 4-1. Charge battery for 15 minutes. Replace battery on the IXL circuit card. Replace IXL card.	Go to 3.
3. Do all indicators operate properly (ie, light and extinguish under normal operation)?	Go to 4.	Check continuity through depressed interlock switch.  Perform Controller Self-Test — See Controller Troubleshooting, Page 4-1.  Perform Keyboard Self-Test — See How To Operate Manual 423.  Replace logic card.  If alarm indicator fails on low paper, go to Printer Troubleshooting, Page 2-1.
4. Can any characters be locally generated from the keyboard to the printer?	Go to 5.	Go to Printer Troubleshooting, Page 2-1.  Replace logic card.
5. Are characters properly formed?	Go to 6.	Go to Printer Troubleshooting, Page 2-1.  Replace logic card.
6. Is print density acceptable? (Good Ribbon)	Go to 7.	Go to Printer Troubleshooting, Page 2-1.
7. Does terminal have a paper tape (PT) unit?	Go to 8.	Go to 9.
8. Does problem appear to be in the paper tape unit?	Go to 22.	Go to 9.
9. Does paper feed properly?	Go to 10.	Check fuse (f3) on logic card. Replace line feed motor if fuse blows again.  Go to Printer Troubleshooting, Page 2-1.  Replace logic card.



QUESTION	YES	NO
10. Does print head space and return properly?	Go to 11.	Go to Printer Troubleshooting, Page 2-1. Replace logic card.
11. Do all characters print, including numeric pad, and functions perform (except bell and keyboard edit cluster), when the keys on the keyboard are operated locally, from the keyboard to the printer?	Go to 12.	Perform keyboard Self-Test — See How To Operate Manual 423 Replace logic card.
12. Does signal bell ring under any conditions? (CTRL J, right margin, etc.)	Go to 13	Go to Printer Troubleshooting, Page 2-1. Perform Controller Self-Test — See Page 4-1. Replace logic card.
13. Does signal bell ring under all conditions?	Go to 14.	Perform Controller Self-Test — See Page 4-1.
14. Are margins set, cleared and right margin released properly?	Go to 15.	Perform Controller Self-Test — See Page 4-1.
15. Can options prep mode be entered, options changed and loaded properly?	Go to 16.	Perform Controller Self-Test — See Page 4-1.
16. Does answer-back print correctly on CTRL 4?	Go to 17.	Check user programmable options for ABmsg coded. Perform Controller Self-Test — See Page 4-1.
17. Can data be entered into buffer, edited, printed out, stored, recalled and cleared properly?	Go to 18.	Perform Controller Self-Test — See Page 4-1.
18. Does Term On Line light after current reversal to the terminal (done locally or by the exchange)?	Go to 19.	Perform Controller Self-Test — See Page 4-1. Check cable to Telex lines. Check external communication equipment.

## D. TROUBLESHOOTING (Contd)

## 3. TROUBLESHOOTING GUIDE (Pedestal Based) (Contd)

QUESTION	YES	NO
19. Is sent data received by remote terminal?	Go to 20.	Go to 19a.
19a. When teleprinter is sending, does send light flash on controller CIU/SSI card?	<p>Check cable from controller to Telex interface card.</p> <p>Check connection from Telex interface card to Telex lines.</p> <p>Check controller Self-Test — See Page 4-1.</p> <p>Check external communication equipment.</p>	Perform Controller Self-Test — See Page 4-1.
20. Is data sent from remote terminal received?	Go to 21.	Go to 20a.
20a. When remote terminal is sending, does receive light flash on controller CIU/SSI card?	Perform Controller Self-Test — See Page 4-1.	<p>Check cable from controller to Telex interface card.</p> <p>Check connection from Telex interface to Telex lines.</p> <p>Perform Controller Self-Test — See Page 4-1.</p> <p>Check external communication equipment.</p>
21. Are data messages properly sent and received in term on-line mode (both batch and S/R)?	Place in service.	<p>Check user programmable option - Speed.</p> <p>Perform Controller Self-Test — See Page 4-1.</p> <p>If self-test is OK, check external communications equipment.</p>
22. Is green indicator on PT unit lit (PT unit power switch on)?	Go to 23	<p>Check power cable connection to ac distribution strip.</p> <p>With power to PT unit off, check PT unit main fuse.</p> <p>If fuse is OK, refer to PT unit Service Manual 422.</p> <p>Replace fuse, if blown. Go to 22a.</p>

QUESTION	YES	NO
22a. Does green indicator on PT unit now light when power is turn on?	Original trouble is corrected.	Trouble is in PT unit. Refer to Service Manual 422. Do not replace fuse second time.
23. Can reader locally send characters to the printer?	Go to 24.	<p>Check cable from PT unit to controller.</p> <p>Check PTR Off/Local — Normal Switch is in the normal position.</p> <p>Perform Controller Self-Test — See Page 4-1.</p> <p>Refer to PT unit Service Manual 422.</p>
24. Is data from reader to printer garbled?	<p>Check that CPS switch on PT unit is in 30 position.</p> <p>Check PT unit Option 455.</p> <p>Perform Controller Self-Test — See Page 4-1.</p> <p>If controller self-test is OK, trouble is in PT unit. Refer to Manual 422.</p>	Go to 25.
25. Does punch receive errorless data from reader?	Place in Service.	<p>Perform Controller Self-Test — See Page 4-1.</p> <p>If controller self-test is OK, trouble is in PT unit, refer to Service Manual 422.</p>

D. TROUBLESHOOTING (Contd)4. TROUBLESHOOTING GUIDE (Tabletop)

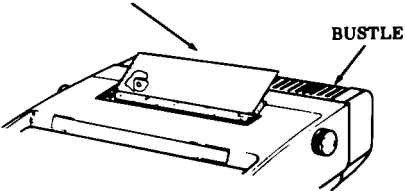
<u>QUESTION</u>	<u>YES</u>	<u>NO</u>
1. Are any indicators on keyboard lit? (Power available, ac cord plugged in, power switch on KP and PT unit (ASR), and cover closed.)	Go to 2.	Go to 1a.
1a. Is there any indication of power in the set? (Keyboard lamps flash when power is turned on and off, print head indexes to the left. RED lamp on power supply lit, etc.)	Go to 1c.	With power off, check ac F1 fuse. (See Page 1-60.)  If fuse is OK, go to 1c.  Replace fuse if blown. Go to 1b.
1b. Do any indicators now light when power is turned on?	Original trouble is corrected.	Replace Power Supply. Replace rear frame assembly.
1c. Is RED lamp on power supply lit?  (Visible through slot in bustle, 6th slot from left.)  	Check cable to controller card assembly.  Check seating of power supply output cable.  Check opcon cable plug.  Perform Controller Self-Test — See Controller Troubleshooting, Page 4-1.  Perform Keyboard Self-Test — See Page 6-1.  Replace controller card assembly. Replace Logic card.	Disconnect power supply cable from power supply and go to 1d.
1d. Does RED lamp on power supply now light?	Unplug controller cable, keyboard and all printer cables (7).  Reconnect power supply cable and go to 1e.	Check Fuse (F2) on power supply. Replace if blown.  Replace power supply.  Replace rear frame assembly.

QUESTION	YES	NO
1e. Does RED lamp on power supply still light?	Go to 1f.	Replace logic card.
1f. Does RED lamp on power supply go out after the controller card assembly, keyboard and printer cables are reconnected one at a time?	Replace the controller card assembly, keyboard or the printer component (refer to Printer Troubleshooting, Page 2-1) that caused lamp to extinguish.	Intermittent short. Check for foreign objects between circuit lands or terminals.
2. Does set continually go to options prep mode when powering up.	Perform Controller Self-Test — See Controller Troubleshooting, Page 4-1. Charge or replace battery on the controller card assembly. Replace controller card assembly.	Go to 3.
3. Do all indicators operate properly (ie, light and extinguish under normal operation)?	Go to 4.	Check continuity through depressed interlock switch.  Perform Controller Self-Test — See Controller Troubleshooting, Page 4-1.  Perform Keyboard Self-Test.  Replace logic card.  If alarm indicator fails on low paper, go to Printer Troubleshooting, Page 2-1.
4. Can any characters be locally generated from the keyboard to the printer?	Go to 5.	Check Controller Switch (SPA7) positions. Go to Printer Troubleshooting, Page 2-1. Replace logic card.
5. Are characters properly formed and lines printing perpendicular to paper edge?	Go to 6.	Go to Printer Troubleshooting, Page 2-1.  Replace logic card.
6. Is print density acceptable? (Good Ribbon)	Go to 7.	Go to Printer Troubleshooting, Page 2-1.
7. Does terminal have a paper tape (PT) unit?	Go to 8.	Go to 9.
8. Does problem appear to be in the paper tape unit?	Go to 21.	Go to 9.
9. Does paper feed properly?	Go to 10.	Check fuse (f3) on logic card. Replace line feed motor if fuse blows again.  Go to Printer Troubleshooting, Page 2-1.  Replace logic card.

## D. TROUBLESHOOTING (Contd)

## 4. TROUBLESHOOTING GUIDE (Tabletop) (Contd)

QUESTION	YES	NO
10. Does print head space and return properly?	Go to 11.	Go to Printer Troubleshooting, Page 2-1. Replace logic card.
11. Do all characters print, including numeric pad, and functions perform (except bell and keyboard edit cluster), when the keys on the keyboard are operated locally?	Go to 12.	Perform Keyboard Self-Test. Replace logic card.
12. Does signal bell ring under any conditions? (CTRL G, right margin, received interrupt, etc.)	Go to 13.	Go to Printer Troubleshooting, Page 2-1.  Perform Controller Self-Test — See Page 4-1.  Replace logic card.
13. Does signal bell ring under all conditions?	Go to 14.	Perform Controller Self-Test — See Page 4-1.
14. Are horizontal tabs set properly?	Go to 15.	Perform Controller Self-Test — See Page 4-1.
15. Can options prep mode be entered, options changed and loaded properly?	Go to 16.	Perform Controller Self-Test — See Page 4-1.
16. Does answer-back print correctly when  is depressed?	Go to 17.	Perform user programmable options for ABmsg coded.  Perform Controller Self-Test — See Page 4-1.
17. Can data be entered into buffer, edited, printed out, stored, recalled and cleared properly?	Go to 18.	Perform Controller Self-Test — See Page 4-1.
18. Does On-Line light after data terminal ready lead is turned on (done locally or by the exchange)?	Go to 19.	Perform Controller Self-Test — See Page 4-1.  Check cable to interface unit.  Check cable to Telex lines.  Check interface unit.  Check external communication equipment.

QUESTION	YES	NO
19. Can any data be both sent and received on-line?	Go to 20.	<p>Perform Controller Self-Test — See Page 4-1.</p> <p>Check cable to interface unit.</p> <p>Check cable to Telex lines.</p> <p>Check interface unit.</p> <p>Check external communication equipment.</p>
20. Are data messages properly sent and received in on-line mode (both batch and S/R)?	Place in service.	<p>Check user programmable option-Speed.</p> <p>Perform Controller Self-Test — See Page 4-1.</p> <p>Check interface unit.</p> <p>Check external communication equipment.</p>
21. Is green indicator on PT unit lit (PT unit power switch on)?	Go to 22.	<p>With power to PT unit off, check PT unit main fuse.</p> <p>If fuse is OK, refer to PT unit Service Manual 422.</p> <p>Replace fuse if blown.</p> <p>Go to 21a.</p>
21a. Does green indicator on PT unit now light when power is turned on?	Original trouble is corrected.	Trouble is in PT unit refer to Service Manual 422. Do not replace fuse second time.
22. Can reader locally send characters to the printer?	Go to 23.	<p>Check cable from PT unit to controller.</p> <p>Check PTR Off/Local-Normal Switch is in the normal position.</p> <p>Perform Controller Self-Test — See Page 4-1.</p> <p>Refer to PT unit Service Manual 422.</p>

D. TROUBLESHOOTING (Contd)4. TROUBLESHOOTING GUIDE (Tabletop) (Contd)

QUESTION	YES	NO
23. Is data from reader to printer garbled?	Check that CPS switch on PT unit is in 30 position.  Check PT unit Option 455.  Perform Controller Self-Test — See Page 4-1.  If controller self-test is OK, trouble is in PT unit. Refer to Manual 422.	Go to 24.
24. Does punch receive errorless data from reader?	Place in service.	Perform Controller Self-Test — See Page 4-1.  If controller self-test is OK, trouble is in PT unit, refer to Service Manual 422.

E. WIRINGCONTENTSPAGE

1. GENERAL .....	1-56
2. TELEPRINTER WIRING (Pedestal Based) .....	1-57
3. TELEPRINTER WIRING (Tabletop) .....	1-60

1. GENERAL

- 1.01 This part provides wiring information for the 42 Buffered KSR and ASR Teleprinters. The wiring information provides proper component interconnection information.
- 1.02 For additional information refer to Page 2-4 Printer Wiring, Page 3-3 Keyboard Wiring and Page 4-5 Controller with Power Supply Wiring (Pedestal Based). For wiring information on the PT (Paper Tape) unit refer to Service Manual 422.
- 1.03 Numbers shown on the terminal wiring do not appear on plugs and jacks.



2. TERMINAL WIRING (Pedestal Based)

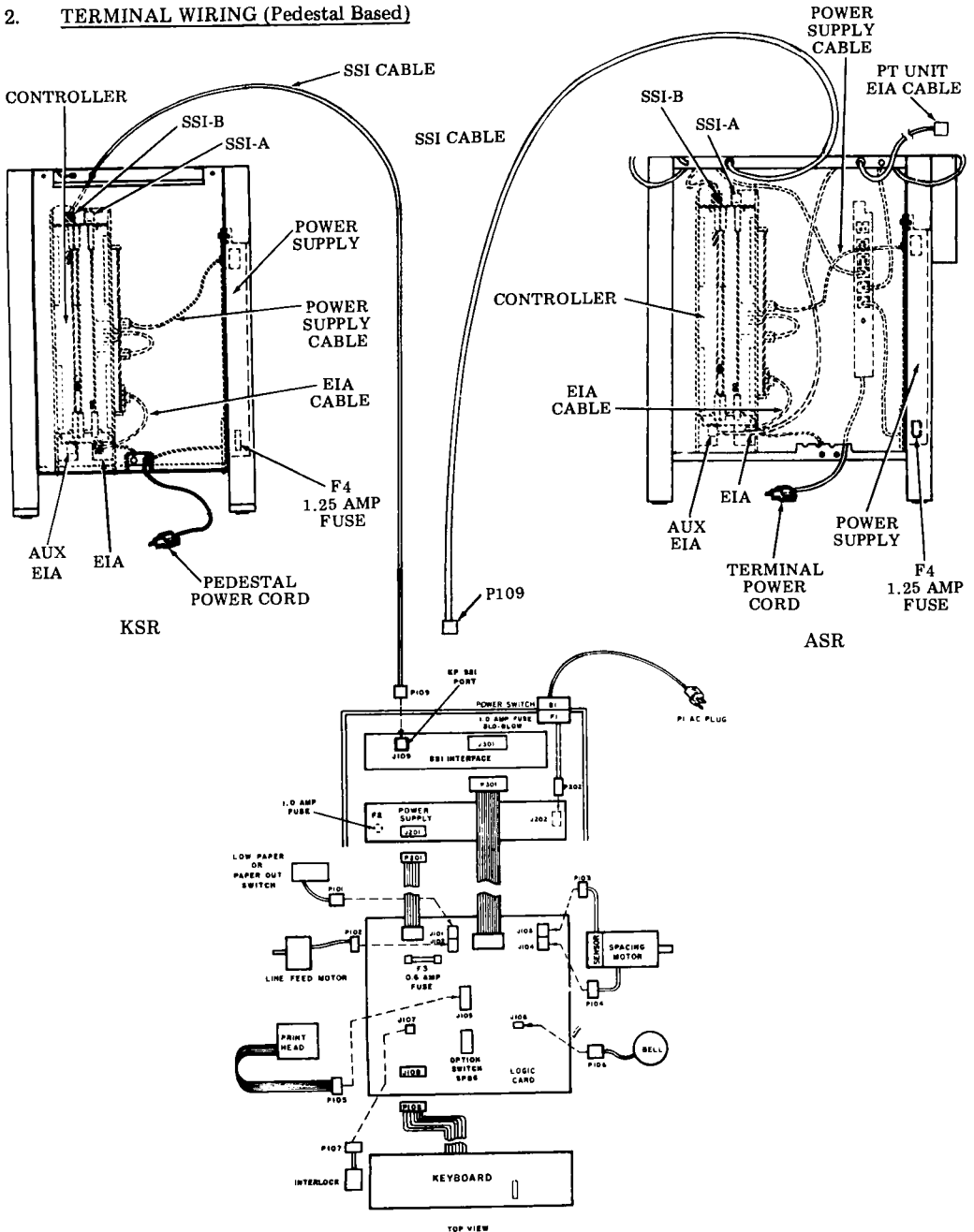

E. WIRING (Contd)

2. TERMINAL WIRING (Pedestal Based) (Contd)

**EIA CABLE**

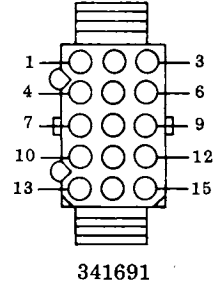
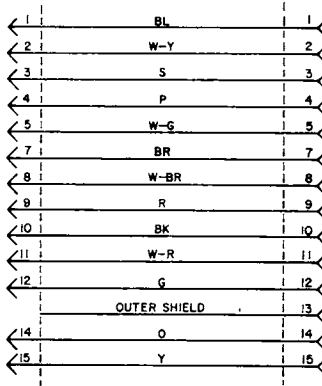
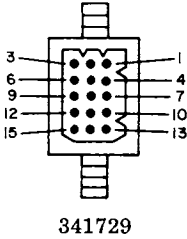

**SSI CABLE**

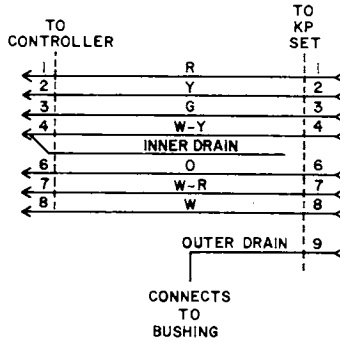

**POWER SUPPLY CABLE**

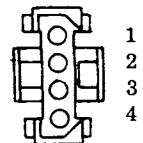
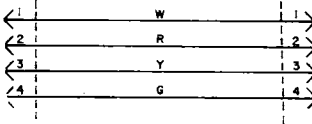
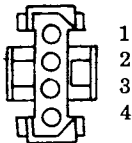

412343 PT UNIT EIA CABLE

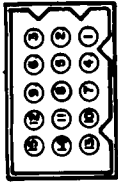

Connector A

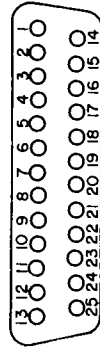
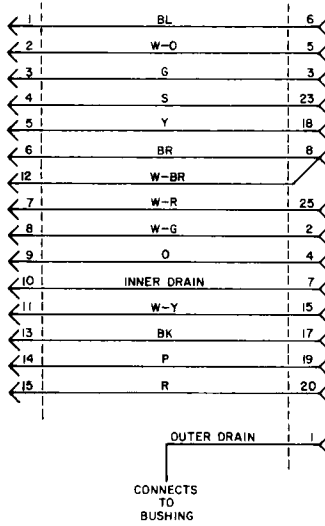

Connector B

INTERLOCK SWITCH ASSEMBLY

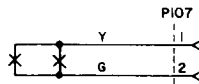

E. WIRING (Contd)

3. TERMINAL WIRING (Tabletop)

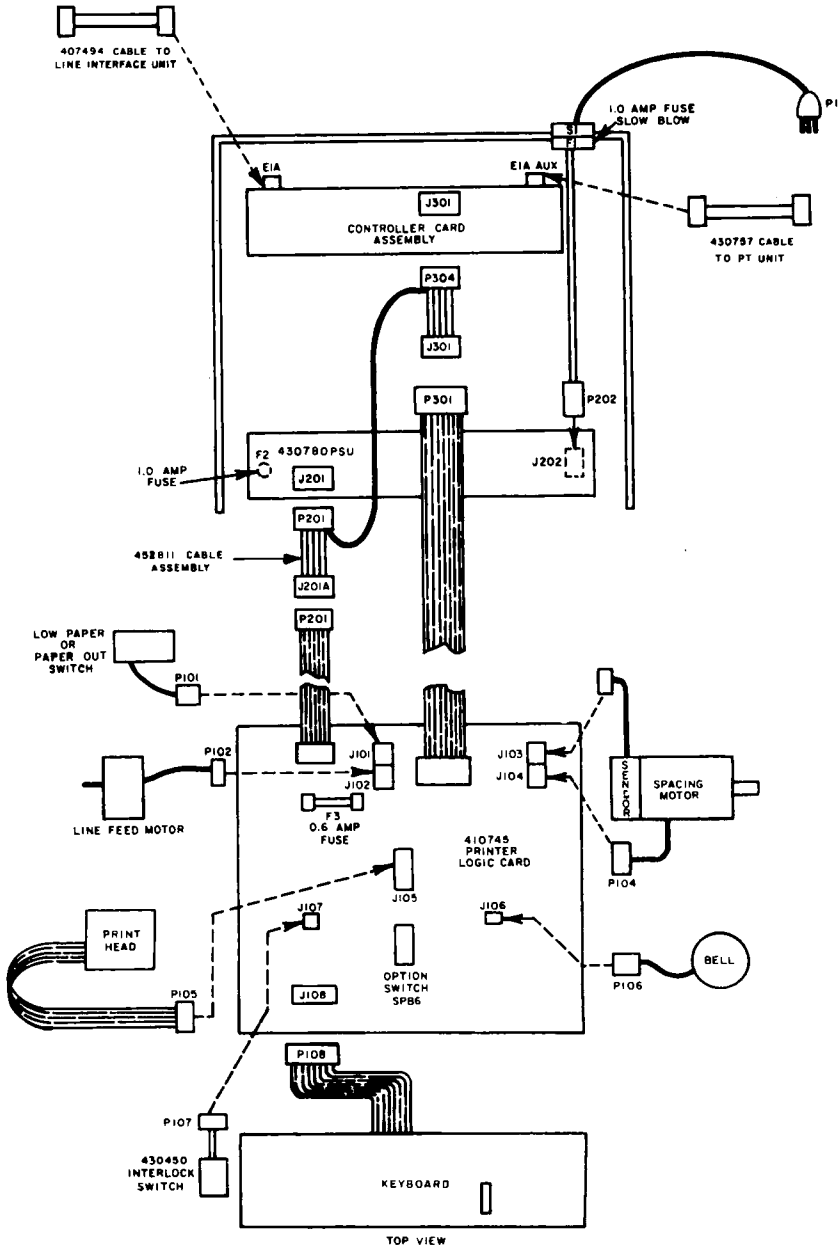

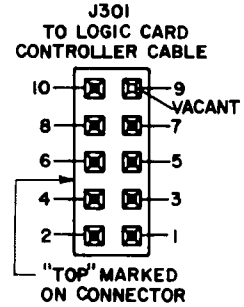
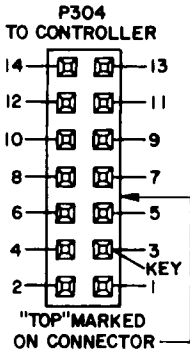
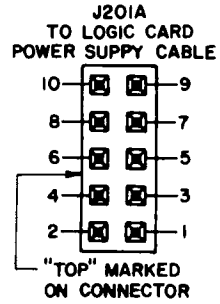
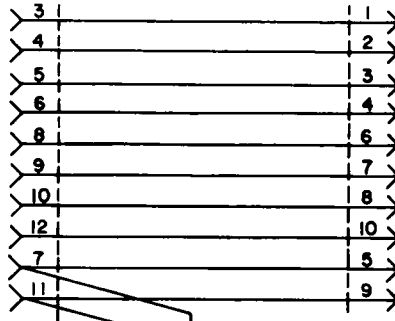
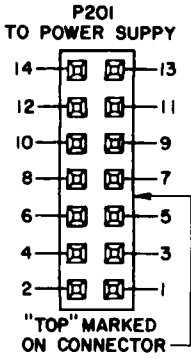

**4528II CABLE ASSEMBLY**

**INTERLOCK SWITCH ASSEMBLY**

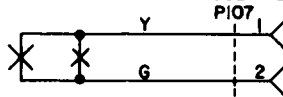

E. WIRING (Contd)

3. TERMINAL WIRING (Tabletop) (Contd)

TO PAPER TAPE UNIT

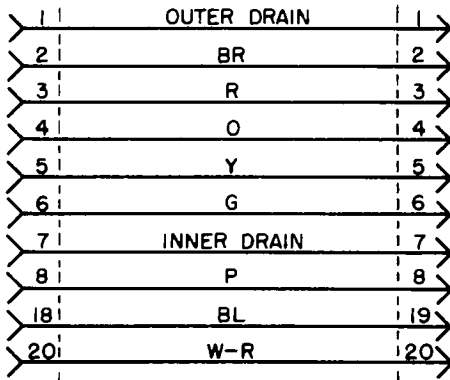
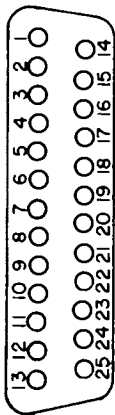

430757 CABLE ASSEMBLY

TO AUX PORT

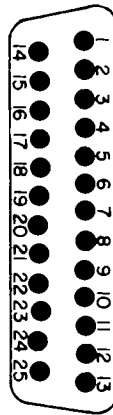

TO LINE PORT

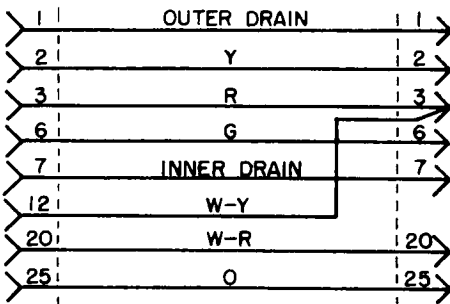
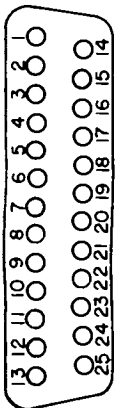

407494 CABLE ASSEMBLY

TO INTERFACE UNIT

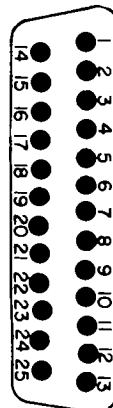

F. TESTING

	<u>CONTENTS</u>	<u>PAGE</u>
1.	GENERAL .....	1-63
	PRELIMINARY CHECK. ....	1-63
2.	TEST EQUIPMENT (Pedestal Based) .....	1-64
3.	TESTING PROCEDURES (Pedestal Based) .....	1-64
	OFF-LINE TEST KSR AND ASR (Installation and Trouble Call Checkout) .....	1-64
	SIMULATED ON-LINE TEST KSR AND ASR (Installation and Trouble Call Checkout) .....	1-72
4.	TEST EQUIPMENT (Tabletop) .....	1-78
5.	TESTING PROCEDURES (Tabletop) .....	1-78
	OFF-LINE TEST KSR and ASR (Installation and Trouble Call Checkout) .....	1-78
	SIMULATED ON-LINE TEST KSR AND ASR (Installation and Trouble Call Checkout) .....	1-86

1. GENERAL

- 1.01 This part provides station testing information for the 42 Buffered KSR and ASR Teleprinters.
- 1.02 An installation checkout should be performed after installation to make sure the station is operable.
- 1.03 On trouble calls an installation checkout should be performed. after trouble correction to make sure the teleprinter is operable and a trouble verification test should be performed under the direction of a test station (if available) to isolate specific troubles not covered in the installation test. After correction of a trouble the test may be confined to the specific area that was failing.

1.04 Following routine maintenance calls at a location, an installation checkout should be performed.

1.05 The checkout routines are present in chart form with test conditions arranged in a specific sequence. A response is given to verify the test condition has passed.

1.06 Refer to Page 1-47 for Pedestal Based Teleprinter Troubleshooting information or Page 1-52 for Tabletop Teleprinter Troubleshooting information.

1.07 If the indicated response is not obtained in any step of a test procedure, repeat the step to make sure that the procedure has been performed properly. If the results are still unsatisfactory, refer to the Teleprinter Troubleshooting Page 1-47 or Page 1-52.

1.08 Always perform the test in the order given. The Test Steps are based on satisfactory results of all previous steps.

PRELIMINARY CHECK

1.09 Before proceeding with the checkout procedure check the following:

- (a) Is teleprinter connected to a properly grounded and polarized ac service?
- (b) Are all cable connectors fully seated?
- (c) Are printer paper, ribbon and paper tape (ASR) properly installed?
- (d) Are any option exceptions present? Refer to Page 1-36.

*Note:* All reference to columns are after a one second delay, to allow the print head to index two character spaces to the right. The print head indicator points to the position of the next character to be printed.

1.10 On-line test can be simulated using the Test Arrangement shown in 2. TEST EQUIPMENT (Pedestal Based) or 4. TEST EQUIPMENT (Tabletop).

F. TESTING (Contd)

2. TEST EQUIPMENT (Pedestal Based)

2.01 To simulate on-line tests, the following test equipment is required:

- (a) One of the following line current supplies:
  1. 120 Vdc 20, 40, or 60 mA.
  2. 60 Vdc 20, 40 mA.

Note: 60 Vdc, 20 mA is required for RCA Global teleprinters.

- (b) A 5-level, 7.5 unit code, 75 baud signal generator capable of sending programmable characters and sequences of characters and interfacing to a current loop.
- (c) A 5-level, 7.5 unit code, 75 baud monitoring device capable of interfacing to a current loop.
- (d) A substitute for (b) and (c) above would be a signal generator that can receive a message, transfer it to the send side and retransmit the same message.

3. TESTING PROCEDURES (Pedestal Based)



3.01 For testing purposes temporarily enable the following user programmable options. See How To Operate Manual for information on enabling the options. See Page 1-34 to enable the last three options.

```

Speed=0075*
LgKey=←*
SnKey=≡*
LfBdy=006*
RtBdy=075*
PtNL?=-N*
DbLF?=-N*
RBSz=01000*
RBuFw=00500*
RBLow=00100*
EBUrN=132*
ABaT=Y*
ROset=N*
BkOST=N*
ABns=AB MESSAGE*
DONE
    
```

NO MEMCLATURE FOR "LETTERS"

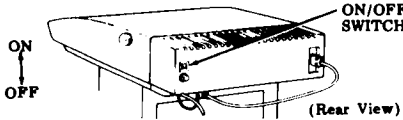
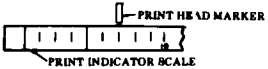
OFF-LINE TESTS KSR AND ASR (Installation and Trouble Call Checkout)

TEST	STEP	PROCEDURE	RESPONSE
Power on	1	Pedestal Based: Turn off KP power switch and remove controller power for at least 3 seconds. With power available to the controller and the KP set, turn on POWER SWITCH. 	Print head is indexed to the left boundary.  Printer performs one (1) line feed. TRM RDY or START and KP keys light. Bell rings once.
Indicator Scale	2		Print head marker points to seventh mark on indicator scale.
Local Return Line Feed	3	Depress TERM LOCAL key and KP key and depress space bar several times.  Hold CTRL key depressed and depress  key.	TERM LOCAL key lights and TRM RDY or START and KP keys go out. Paper feeds one line. Print head spaces several characters.  Print head is returned to left boundary and paper feeds to next line.









TEST	STEP	PROCEDURE	RESPONSE
Data Keys	4	Starting with top row and moving from left to right, depress unshaded keys in Fig. 1.	Characters are printed as in Fig. 2.
<p>Fig. 1</p> <p>?1234567890()+=QWERTYUIOP/ASDFGHJKL:ZXCVBNM,.-</p> <p>Fig. 2</p>			
Return and Line Feed	5	Depress <input type="button" value="←"/> and then <input type="button" value="≡"/> key.	Print head is returned to left boundary and paper feeds to next line.
Rept Key	6	Depress and hold REPT and <input type="button" value="K"/> keys.	The K is continuously printed until the end of line is reached. Signal bell rings at end of line.
Margins Set Release Clear	7	Depress the <input type="button" value="←"/> , <input type="button" value="≡"/> keys then space the print head to Column 10.	Print head is returned to left boundary and paper feeds to next line. Print head spaces to Column 10.
		Hold the CTRL key depressed and depress the <input type="button" value="7"/> key. (Set Left Margin)	No response.
		Space the print head to Column 21.	Print head spaces to Column 21.
		Hold the CTRL key depressed and depress the <input type="button" value="8"/> key. (Set Right Margin)	No response.
		Depress the <input type="button" value="←"/> key.	Print head returns to Column 10.

F. TESTING (Contd)

3. TESTING PROCEDURES (Contd)

OFF-LINE TEST KSR AND ASR (Installation and Trouble Call Checkout) (Contd)

TEST	STEP	PROCEDURE	RESPONSE
Margins Set Release Clear (Cont)	7 (Contd)	Space the print head to Column 20.	Print head spaces to Column 20.
		Depress the  key. (A)	The character A prints and the print head spaces to Column 21.
		Depress the  key. (B)	Bell rings, B does not print.
		Hold the CTRL key depressed and depress the  key. (Release Right Margin)	No response
		Depress  key three times.	Character C prints three times.
		Hold the CTRL key depressed and depress the  key. (Margin clear)	Print head returns to the left boundary.
Numeric Pad Mode	8	Depress  key.	NUM PAD key lights.
		Starting with top row and moving from right to left depress the keys shown in Fig. 3.	Characters are printed as in Fig. 4. Print head returns to left boundary.
		Depress  key.	NUM PAD key goes out.

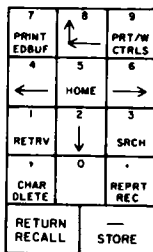















Fig. 3

987654321.0,-



















Fig. 4







TEST	STEP	PROCEDURE	RESPONSE
Control Characters	9	Hold CTRL key depressed and depress  key.	⌘ prints.
		Hold CTRL key depressed and depress  key.	\$ prints.
		Hold CTRL key depressed and depress  key.	ⓑ prints.
		Hold CTRL key depressed and depress  key.	# prints.
		Hold CTRL key depressed and depress  key.	Bell rings.
Space Bar	10	Depress space bar.	Print head moves one character position to the right.
	11	Depress  key.	BUFFER ENTER key lights. Paper feeds one line.
		Depress  then  keys. (A & C)	A C Prints.
		Depress  key once. (Buffer Backspace).	Print head backspaces once.
		Depress  key.	Insert key lights.
		Depress  key. (B)	B prints over C.
		Depress  key.	INSERT key goes out.
		Depress  key. (Buffer Home)	Print head returns to left boundary, paper feeds one line.
		Depress  key. (Print Edit Buffer)	ABC prints.

## F. TESTING (Contd)

## 3. TESTING PROCEDURES (Contd)

## OFF-LINE TEST KSR AND ASR (Installation and Trouble Call Checkout ) (Contd)

TEST	STEP	PROCEDURE	RESPONSE
Buffer Character Delete	12	Depress  key. (Prev. Line)	Print head moves to left boundary and paper feeds one line.
		Depress  key. (Buffer Space)	A prints.
		Depress  key. (Character Delete)	■ prints.
		Depress  then  keys.	AC prints.
Clear Buffer	13	Depress  ,  then  keys.	Bell rings when  key is depressed.
Buffer Print With Control Characters	14	Type ABC < ≡	ABC DEF is printed.
		Depress  then  keys.	ABC ← ≡ DEF is printed.
Buffer Next Line Control	15	Depress  then  keys. (Buffer Next Line)	Print head returns to left boundary, paper feeds two lines.
		Depress  key.	DEF is printed.
Message Store And Recall	16	Depress  key. (Store)	 key lights. Print head is returned to left boundary and paper feeds one line.
		Depress  key. (Recall)	 key goes out. Paper feeds one line.
		Depress  key.	ABC DEF is printed.

TEST	STEP	PROCEDURE	RESPONSE
Buffer String Enter And Search	17	Depress  key.	Print head is returned to left boundary and paper feeds one line.
		Depress  key.	String enter key lights. Paper feeds one line.
		Depress  key. (E)	E prints.
		Depress  key.	String enter key goes out.
		Depress  key. (Search)	DE is printed.
Alarm Conditions	18	Open the teleprinter cover.	ALARM key lights.
		Close cover.	ALARM key goes out.
		Remove paper from the teleprinter.	ALARM key lights and bell rings.
		Replace paper and depress  key. On friction feed teleprinters it may be necessary to depress the reset button on paper roll support before depressing the ALARM key.	ALARM key goes out.

ASR Terminals go to Step 19.



Western Union KSR Teleprinters go to Step 25.

RCA Global KSR Teleprinters go to Step 26.

## F. TESTING (Contd)

## 3. TESTING PROCEDURES (Contd)

## OFF-LINE TEST ASR ONLY (Installation and Trouble Call Checkout)

TEST	STEP	PROCEDURE	RESPONSE
Punch controls on, off and feed.	19	Place terminal in term local mode and KP-LCL.	 key lit and  key off.
		Operate punch control switch to the on position.	Punch lamp lights.
		Depress punch control feed switch until three inches of tape feeds out.	Three inches of tape feeds out and only feed holes are punched.
		Depress  key then type ABCDEF.	Several characters are punched in tape.
		Depress punch control feed switch until three inches of tape feeds out. Operate punch control switch to the off position.	Punch lamp goes out.
Reader controls on and off. Verify proper punching and reading of tape.	20	Tear off tape from punch.	
		Operate reader control switch to the off position.	
		Load tape in reader.	
		Operate reader control switch to the on position.	Reader lamp lights. Reader steps tape. ABCDEF is printed and reader lamp flashes when out of tape.
		Operate reader control switch to the off position.	Reader lamp goes out.
Punch Control Auto	21	Depress punch control feed switch until three inches of tape feeds out.	Three inches of tape feeds out and only feed holes are punched.
		Operate punch control switch to auto position.	
		Type ABCD.	No response from punch.
		Type CCCC	Punch lamp turns on.
		Type ABCDEFAAAA	Characters are punched in tape.

TEST	STEP	PROCEDURE	RESPONSE
Punch Control Auto	21 (Contd)	Type FFFF	Characters are punched in tape and punch light goes out after FFFF is punched.
		Operate punch control switch to off position.  Depress punch control feed switch until three inches of tape feeds out. Tear off tape.	
Reader Control Auto	22	Operate reader control switch to auto position.  Load tape in reader.  Type SSSS.	Reader lamp lights. Reader steps tape. ABCDEF AAAA FFFF prints. Reader stops before running out of tape. Reader lamp turns off.
		Operate reader control switch to off position.	
Reader Control Step and Skip	23	Place same tape in reader with first character A (1 & 2 punched) in line with reader sensor designated by arrow.  Depress reader step switch one time.	Reader steps once and character A prints.
		Depress reader skip switch one time.	Reader steps once but no character is printed.
Punch Control Backspace	24	Operate punch control switch to on position.	Punch lamp lights.
		Depress <input type="checkbox"/> LTRS key.	Character is punched.
		Depress punch backspace switch one time	Tape backs up in punch one character.
		Depress <input type="checkbox"/> LTRS key then feed out tape until letters code (1-5 punched) is visible.	Code holes 1-5 are punched and are not elongated by backspacing and repunching.

Western Union Teleprinters go to Step 25.  
RCA Global Teleprinters go to Step 26.

F. TESTING (Contd)

3. TESTING PROCEDURES (Contd)

SIMULATED ON-LINE TEST KSR AND ASR (Installation and Trouble Call Checkout)



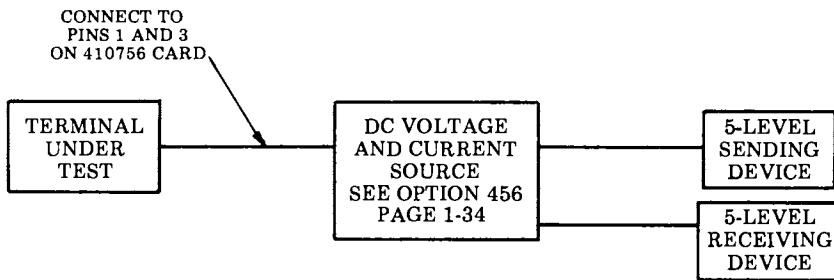













Turn off power to controller and connect to the test arrangement shown below.



Turn on power to the controller.



















SIMULATED ON-LINE TEST KSR AND ASR (Installation and Trouble Call Checkout)























TEST	STEP	PROCEDURE	RESPONSE
Term On-Line Mode Western Union Arrangement Only.	25	Place terminal in TRM RDY and KP-on.	TRM RDY and KP keys light.
		Depress  key.	 key flashes TRM RDY key goes out.
		Within 30 seconds of  beginning to flash, remove line current from teleprinter for 1-3 seconds then reapply line current.	 key lights steadily and  key lights.
		Within 30 seconds of  key, lighting steadily, depress  &  keys on upper row of key-board followed by  &  keys on numeric pad.	Pulsing of the DC loop corresponding to the numbers depressed takes place. The numbers are printed after that specific number has been automatically dialed by the teleprinter.
		Within 30 seconds of dialing reverse line current polarity.  Go to Step 27	 key extinguishes.  key lights and bell rings.
Term On-Line Mode RCA Global Arrangement Only.	26	Place teleprinter in START and KP-on.	START and KP keys light.
		Depress  key.	 key flashes for 3 seconds then remains lit. Bell rings.
		Reverse line current polarity to the terminal.	 key goes out and  key lights. Answer-back message prints.
Answer-back	27	From the signal generator send Figs D. (wru)	† ab message is printed and ab message is transmitted to receiving device.

## F. TESTING (Contd)

## 3. TESTING PROCEDURES (Contd)

## SIMULATED ON-LINE TEST KSR AND ASR (Installation and Trouble Call Checkout) (Contd)





















TEST	STEP	PROCEDURE	RESPONSE
Answer-back	27 (Contd)	Hold CTRL key depressed and depress  key. (Here is).	ab message is printed and transmitted to receiving device.
		Reverse the teleprinter line current polarity until the  or  key lights, then reverse polarity back again. (Simulates auto answer)	ab message is printed and transmitted to receiving device.
KP Seizure	28	Depress lighted  key.	 key goes out.
		Send random text (ie, QUICK BROWN FOX) from the signal generator.	 key lights.
		Continue sending from the signal generator until RBufw value is reached.	 key flashes and bell rings several times.
		Continue sending from the signal generator until RBLow value is reached. Then stop sending.	 key starts to flash and printer prints out all text stored in the receive buffer.
		After text is all printed, depress flashing  key.	 key goes out.
Sending From Buffer	29	Depress  key.	 key lights Print head returns to left boundary and paper feeds one line.
		Enter two full lines of random text and end second line with CTRL = (End of message).	The full lines of random text are printed.
		Depress  key.	 key lights. Print head returns to left boundary and paper feeds one line.
		Depress  key.	 key lights and  key goes out.





TEST	STEP	PROCEDURE	RESPONSE
Sending From Buffer	29 (Contd)	Depress  key.	 key flashes. two full lines of characters are sent to the receiving device then the  key goes out.
Keyboard Send	30	Type random text from the keyboard.	Random text is correctly received by the receiving device.
Reprint Receive	31	Reverse the teleprinter line current polarity until the  or  key lights. Then reverse polarity back again (simulates auto answer).	ab message is printed is printed and transmitted to the line.
		From the signal generator send two lines of text.	Two lines of text are printed.
		Reverse the teleprinter line current polarity.	Bell rings,  key goes out and  or  key lights.
		Depress  key.	 key lights and  or  key goes out.
		Depress  key.	 key goes out.
		Depress  key one time.	 key lights.
		Depress  key.	 key lights. ab message is printed and the two lines of text that was sent from the signal generator is printed
Retrieve Acknowledged Message	32	Depress  or  key.	 key goes out and  or  key lights.

## F. TESTING (Contd)

## 3. TESTING PROCEDURES (Contd)

## SIMULATED ON-LINE TEST KSR AND ASR (Installation and Trouble Call Checkout) (Contd)

TEST	STEP	PROCEDURE	RESPONSE
Retrieve Acknowledged Message	32 (Contd)	Reverse the terminal line current polarity.	 or  key goes out and  key lights. ab message is printed.
		Depress  key.	 key lights and  key goes out.
		Depress  key. Depress  key several times until bell rings (Empty edit buffer). Type ABCDEF followed by CTRL = (end of message)	ABCDEF prints.
		Depress  key.	 key lights.
		Depress  key.	 key lights and  key goes out.
		Depress  key.	abcdef is printed and transmitted to receiving device.  key goes out after sending.
		Depress  key. (Acknowledges message)	No Response.
		Depress  key.	 key lights and  key goes out.  Print head returns to left boundary and paper feeds one line.
		Depress  key.	 key lights and paper feeds one line.
		Type CD.	CD prints.

TEST	STEP	PROCEDURE	RESPONSE
Retrieve Acknowledged Message	32 (Contd)	Depress  key.	 key goes out. Print head returns to left boundary, and ABCD prints.
		Depress  key.	Print head returns to left boundary and paper feeds one line.
		Depress  key.	ABCDEF prints.

F. TESTING (Contd)

4. TEST EQUIPEMNT (Tabletop)

- 4.01 To simulate on-line tests, the following test equipment is required:
- (a) A 5-level, 7.5 unit code, 75 baud signal generator capable of sending programmable characters and sequence of characters and having an EIA interface.
  - (b) A 5-level, 7.5 unit code, 75 baud monitoring device having an EIA interface.
  - (c) A substitute for (a) and (b) above would be a signal generator that can receive a message, transfer it to the send side and retransmit the same message.
  - (d) A 407494 cable locally modified to add a switch (SW1) in the DSR lead as shown below:

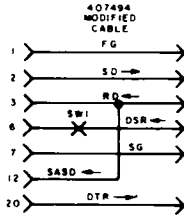

5. TESTING PROCEDURES (Tabletop)



5.01 For testing purposes temporarily enable the following user programmable options. See How To Operate Manual for information on enabling the options. See Page 1-36 to enable the last twenty options.

```

Auto1=AUTO 1*  LfBdy=06*
Auto2=*        RtBdy=79*
Auto3=*        R0set=N*
Auto4=*        Bk08T=N*
Auto5=*        Tsmal=N*
Auto6=*        PtBel=N*
Auto7=*        Ltape=Y*
Auto8=*        CtD1y=1700*
Auto9=*        DctD1=1000*
HzTab=10*     BsyD1=300*
<Key?=<*     Sbrk?=<3000*
≡Key?≡*     PDSpu=60*
DbLFY=N*     PDDne=1*
RBSze=01000* Prcl=1*
RBufu=00500* ABmsg=AB MESSAGE*
Seize=00100* ****
EBWrrn=132*
Speed=0075*
    
```

NOMENCLATURE FOR LETTERS

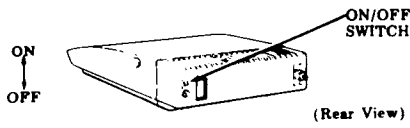
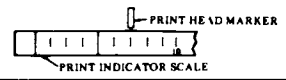
OFF-LINE TESTS KSR AND ASR (Installation and Trouble Call Checkout)

TEST	STEP	PROCEDURE	RESPONSE
Power on	1	Turn off power switch for at least 3 seconds. Then turn on POWER SWITCH.  (Rear View)	Print head is indexed to the left boundary. Printer performs one (1) line feed and IN SERVICE lamp lights.
Indicator Scale	2	 PRINT HEAD MARKER PRINT INDICATOR SCALE	Print head marker points to seventh mark on indicator scale.
Local Return Line Feed	3	Depress LOCAL PREP key then depress space bar several times.  Hold CTRL key depressed and depress  key.	LOCAL PREP key lights. Print head spaces several characters.  Print head is returned to left boundary and paper feeds to next line.

TEST	STEP	PROCEDURE	RESPONSE
Data Keys	4	Starting with top row and moving from left to right, depress unshaded keys in Fig. 1.	Characters are printed as in Fig. 2.

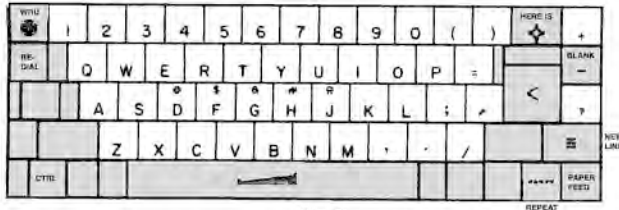









Fig. 1

1234567890()+QWERTYUIOP=ASDFGHJKL; ' ? ZXCVBNM.,./

Fig. 2

Return and line feed keys	5	Depress  then  key.	Print head is returned to left boundary and paper feeds to next line.
 Key (Repeat)	6	Depress and hold  and  keys.	The K is continuously printed until the end of line is reached. Signal bell rings at end of line.
Paper Feed Key	7	Depress  key.	Print head is returned to left boundary and paper feeds to next line.
Numeric Pad Mode	8	Depress  key.	NUM PAD key lights.
		Starting with top row and moving from left to right depress unshaded keys shown in Fig. 3	Characters are printed as in Fig. 4.
		Depress  key.	NUM PAD key goes out.

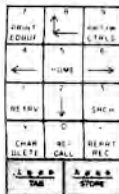

Fig. 3













789456123,0.

Fig. 4



















## F. TESTING (Contd)

## 5. TESTING PROCEDURES (Tabletop) (Contd)

## OFF-LINE TESTS KSR AND ASR (Installation and Trouble Call Checkout) (Contd)

TEST	STEP	PROCEDURE	RESPONSE
Control Characters	9	Hold CTRL key depressed and depress  key.	† Prints.
		Hold CTRL key depressed and depress  key.	‡ Prints.
		Hold CTRL key depressed and depress  key.	& Prints.
		Hold CTRL key depressed and depress  key.	* Prints.
		Hold CTRL key depressed and depress  key.	Bell rings.
Space Bar	10	Depress space bar.	Print head moves one character position to the right.
WRU	11	Depress  key.	‡ Prints
Here is	12	Depress  key.	AB Message prints.
Auto Keys	13	Hold CTRL key depressed and Depress  key.	AUTO 1 prints.
Horizontal	14	Depress  then  keys.	Print head returns to the left boundary and paper feeds one line.
		Depress  key.	1 prints in Column 7.
		Depress  (Horizontal Tab) then  key.	Print head spaces to the right and 2 prints in column 17.























TEST	STEP	PROCEDURE	RESPONSE
Buffer Character Insert	15	Depress  key.	Memory key lights. Print head returns to left boundary and paper feeds one line.
		Depress  then  keys. (A & C)	AC Prints.
		Depress  key once. (Buffer Backspace).	Print head backspaces once.
		Depress  key.	INSERT key lights.
		Depress  key. (B)	B prints over C.
		Depress  key.	INSERT key goes out.
		Depress  key. (Buffer Home)	Print head returns to left boundary, paper feeds one line.
		Depress  key. (Print Edit Buffer)	ABC prints.
Buffer Character Delete	16	Depress  key. (Prev. Line)	Print head moves to left boundary and paper feeds one line.
		Depress  key. (Buffer Space)	A prints.
		Depress  key. (Character Delete)	■ prints.
		Depress  then  keys.	AC prints.
Clear Buffer	17	Depress  ,  then  keys.	Bell rings when  key is depressed.

## F. TESTING (Contd)

## 5. TESTING PROCEDURES (Tabletop) (Contd)

## OFF-LINE TESTS KSR AND ASR (Installation and Trouble Call Checkout) (Contd)

TEST	STEP	PROCEDURE	RESPONSE
Buffer Print With Control Characters	18	Type ABC < ≡ DEF.	ABC DEF is printed
		Depress  then  keys.	ABC < ≡ DEF is printed.
Buffer Next Line Control	19	Depress  then  keys. (Buffer Next Line)	Print head returns to left boundary, paper feeds two lines.
		Depress  key.	DEF is printed.
Message Store And Recall	20	Depress  key. (Store)	 key lights. Print head is returned to left boundary and paper feeds one line.
		Depress  key. (Recall)	 key goes out. Paper feeds one line.
		Depress  key.	ABC DEF is printed.
Buffer String Enter And Search	21	Depress  key.	Print head is returned to left boundary and paper feeds one line.
		Depress  key.	STRING ENTER key lights. Paper feeds one line
		Depress  key. (E)	E prints.
		Depress  key.	STRING ENTER key goes out.
		Depress  key. (Search)	DE is printed
Alarm Conditions	22	Open the teleprinter cover.	ALARM key lights.
		Close cover.	ALARM key goes out.
		Remove paper from the teleprinter.	ALARM key lights.
		Replace paper and depress  key.	ALARM key goes out.



TEST	STEP	PROCEDURE	RESPONSE
	22 (Contd)	On friction feed teleprinters it may be necessary to depress the reset button on paper roll support before depressing the ALARM key.	
Directory	23	Depress  key.	<p>The following prints out:</p> <p><b>EDIT</b> <b>ABC&lt;EDEF*</b></p> <p><b>SEND</b></p> <p><b>WAS SENT</b></p> <p><b>RECEIVE</b></p> <p>The  key flashes while the above prints.</p>
		<p>ASR Teleprinters Go To Step 24 KSR Teleprinters Go To Step 30</p>	
Punch Controls On, Off And Feed	24	Place teleprinter in LOCAL PREP mode and NUM PAD key lit.	 and  keys are lit.
		Operate punch control switch to the on position.	Punch lamp lights.
		Depress punch control feed switch until three inches of tape feeds out.	Three inches of tape feeds out and only feed holes are punched.
		Depress  key then type ABCDEF.	Several characters are punched in tape.
		<p>Depress punch control feed switch until three inches of tape feeds out.</p> <p>Operate punch control switch to the off position.</p>	Punch lamp goes out.

## F. TESTING (Contd)

## 5. TESTING PROCEDURES (Tabletop) (Contd)

## OFF-LINE TESTS KSR AND ASR (Installation and Trouble Call Checkout) (Contd)

TEST	STEP	PROCEDURE	RESPONSE
Reader Controls on and off. Verify proper punching and reading of tape.	25	Tear off tape from punch. Operate reader control switch to the off position. Load tape in reader. Operate reader control switch to the on position.	Reader lamp lights. Reader steps tape. ABCDEF is printed and reader lamp flashes when out of tape.
		Operate reader control switch to the off position.	Reader lamp goes out.
Punch Control	26	Depress punch control feed switch until three inches of tape feeds out.	Three inches of tape feeds out only feed holes are punched.
		Operate punch control switch to auto position.	
		Type ABCD.	No response from punch.
		Type CCCC.	Punch lamp turns on.
		Type ABCDEFAAAA.	Characters are punched in tape.
		Type FFFF.	Characters are punched in tape and punch light goes out after FFFF is punched.
		Operate punch control switch to off position. Depress punch control feed switch until three inches of tape feeds out. Tear off tape.	

TEST	STEP	PROCEDURE	RESPONSE
Reader Control Auto	27	Operate reader control switch to auto position.  Load tape in reader.	
		Type SSSS.	Reader lamp lights. Reader steps tape ABCDEF AAAA FFFF prints. Reader stops before running out of tape. Reader lamp turns off.
		Operate reader control switch to off position.	
Reader Control Step and Skip	28	Place the same tape in reader with first character A (1 & 2 punched) in line with reader sensor designated by arrow.  Depress reader step switch one time.	Reader steps once and character A prints.
		Depress reader skip switch one time.	Reader steps once but no character is printed.
Punch Control Backspace	29	Operate punch control switch to on position.	Punch lamp lights.
		Depress  key.	Character is punched.
		Depress punch backspace switch one time.	Tape backs up in punch one character.
		Depress  key then feed out tape until letters code (1-5 punched) is visible.	Code holes 1-5 are punched and are not elongated by backspacing and repunching.

F. TESTING (Contd)







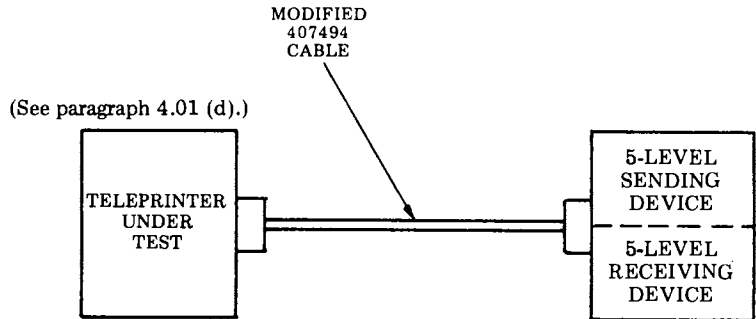













5. TESTING PROCEDURES (Tabletop) (Contd)

SIMULATED ON-LINE TEST KSR AND ASR (Installation and Trouble Call Checkout)

Turn off power to the teleprinter and connect the test arrangement shown below.



















Turn on power to the teleprinter.

TEST	STEP	PROCEDURE	RESPONSE
Dialing	30	With SW1 open on the modified 407494 cable, depress the  key.	 key flashes.
		While the start key is flashing send from the signal generator the character V to the teleprinter.	 key lights steadily and  key lights.
		Within 40 seconds of the  key lighting steadily depress  &  keys on upper row of keyboard followed by  &  keys on the numeric pad.	Dial pulses are sent on-line corresponding to the numbers depressed. The numbers are printed prior to that specific number being automatically dialed by the teleprinter.
		Depress  key.	 key flashes and  and  keys go out.
Redialing	31	Depress the  key.	 key flashes.
		While the start key is flashing send from the signal generator the character V to the teleprinter.	 key lights steadily and  key lights.
		Within 40 seconds of the  key lighting steadily depress the  key.	Dial pulses are sent on-line and the numbers 8, 9, 1 and 6 print. Same numbers as previous step.
On-Line Mode	32	Close SW1 on the Modified 407494 cable.	 key lights and  key goes out.





















## F. TESTING (Contd)

## 5. TESTING PROCEDURES (Tabletop) (Contd)

## SIMULATED ON-LINE TESTS KSR AND ASR (Installation and Trouble Call Checkout) (Contd)

TEST	STEP	PROCEDURE	RESPONSE
Answer-back	33	From the signal generator send Figs D. (WRU)	† is printed and AB message is transmitted to the receiving device.
		Depress  key.	AB message is transmitted to the receiving device.
KP Seizure	34	Depress  key.	 key lights.
		Send random text (ie, QUICK BROWN FOX) from the signal generator.	 key lights.
		Continue sending from the signal generator until RBufw value is reached.	 key flashes and bell rings several times.
		Continue sending from the signal generator until Seize value is reached then stop sending.	 key starts to flash and printer prints all text stored in the receive buffer.
		After text is all printed, depress flashing  key.	 key lights steadily.
Sending from buffer	35	Depress  key.	 key lights. Print head returns to left boundary and paper feeds one line.
		Enter two full lines of random text and end second line with CTRL + (end of message)	Two full lines of random text are printed.
		Depress  key.	 key lights. Print head returns to left boundary and paper feeds one line.
		Depress  key.	 and  keys go out.
		Depress  key.	 key flashes.















TEST	STEP	PROCEDURE	RESPONSE
Sending from buffer	35 (Contd)		Two full lines of random text are sent to the receiving device then the  key goes out.
Keyboard send	36	Type random text from the keyboard.	Random text is correctly received by the receiving device.
Reprint receive	37	Open SW1 on the modified 407494 cable.	 key goes out.
		Close SW1 on the modified 407494 cable.	Bell rings,  and  keys light.
		Depress  key.	 key goes out.
		Send two lines of random text (ie, QUICK BROWN FOX) from the signal generator.	Two lines of random text prints.
		Open SW1 on the modified 407494 cable.	 key goes out.
		Depress LOCAL PREP key.	 key lights.
		Depress  key once.	 key lights.
		Depress  key.	 key goes out, two lines of random text prints, then  key goes out.
Retrieve acknowledged message	38	Close SW1 on the modified 407494 cable.	Bell rings,  and  keys light,
		Depress  key.	 and  keys light and  key goes out.
		Depress  key then  key several times until bell rings (empty edit buffer).	

## F. TESTING (Contd)

## 5. TESTING PROCEDURES (Tabletop) (Contd)

## SIMULATED ON-LINE TESTS KSR AND ASR (Installation and Trouble Call Checkout) (Contd)

TEST	STEP	PROCEDURE	RESPONSE
Retrieve acknowledged message	38 (Contd)	Type ABCDEF followed by CTRL + (end of message).	ABCDEF Prints.
		Depress  key.	 key lights.
		Depress  key.	Memory key goes out.
		Depress  key.	ABCDEF is transmitted to receiving device.  key goes out after sending.
		Depress  key. (Acknowledges message).	No response.
		Depress  key.	Memory key lights. Print head returns to left boundary and paper feeds one line.
		Depress  key.	 key lights and paper feeds one line.
		Type CD.	CD prints
		Depress  key.	 key goes out. Print head returns to left boundary and ABCD prints.
		Depress  key.	Print head returns to left boundary and paper feeds one line.
		Depress  key.	ABCDEF prints.

G. DISASSEMBLY/REASSEMBLY

	<u>CONTENTS</u>	<u>PAGE</u>	<u>Part</u>	<u>Paragraph</u>
1.	GENERAL .....	1-92	Bustle Cover	3.03
2.	TOOLS REQUIRED .....	1-93	Paper Holder	3.03
			Set Cover	3.06
			Rear Frame	3.07
3.	DISASSEMBLY/REASSEMBLY....	1-93		
	KP SET PEDESTAL BASED. ....	1-93		
	PT UNIT PEDESTAL BASED ASR .	1-94	1.03	For disassembly/reassembly of the PT unit major components, refer to Service Manual 422.
	SSI INTERFACE OR CONTROLLER CIRCUIT CARD ASSEMBLY .....	1-95		
	430700, 430760 or 430780 POWER SUPPLY .....	1-96		
	120139 POWER SUPPLY FUSE....	1-96	1.04	The procedures provided in this part break the teleprinter down into subcomponents. The appropriate parts sections illustrate the arrangement of subcomponents and parts -- Page 2-42 Printer Parts and Page 5-3, Paper Handling Enclosures and Parts.
	43K202/GAC OR 43K202/GAD KEYBOARD .....	1-97		
	143307 LOGIC CARD FUSE .....	1-98		
	410745 LOGIC CARD .....	1-99		
	PRINTER .....	1-100		
	A. Removal .....	1-100		
	B. Replacement .....	1-101		<i>Caution: Remove all power from the set before performing any component replacement.</i>
	430850 PRINT HEAD .....	1-102		
	A. Removal .....	1-102	1.05	When removing a major component or part from the teleprinter, do not pry or force parts to provide the necessary clearance for removal so that proper reassembly can be accomplished. For reassembly, reverse the removal procedure except where different instructions are given.
	B. Replacement .....	1-102		
	CONTROLLER CIRCUIT CARDS (Pedestal Based) .....	1-105		
	CONTROLLER (Pedestal Based) ...	1-106		
	430770 POWER SUPPLY (Pedestal Based) .....	1-107		
	307218 POWER SUPPLY FUSE (Pedestal Based) .....	1-107	1.06	Reference in the procedures to left and right and up or down and top or bottom, etc, refer to the teleprinter in its normal operating position.
	406099 BATTERY (Pedestal Based) .....	1-108		
	A. Removal .....	1-108		
	B. Replacement .....	1-108	1.07	Refer to Maintenance Tools, Section 570-005-800TC for a complete listing of maintenance of Teletype Corporation equipment. For a listing of the tools required to perform the disassembly/reassembly procedures, refer to 2. TOOLS REQUIRED.
	406099 BATTERY (Tabletop) .....	1-109		
	A. Removal .....	1-109		
	B. Replacement .....	1-109		
	411959 CARD ASSEMBLY, PROGRAM .....	1-110		
1.	GENERAL			
1.01	This part provides disassembly/reassembly procedures for the 42 Buffered KSR and ASR Teleprinter and their major components.		1.08	When ordering replaceable components, unless otherwise specified, prefix each part number with the letters "TP" (ie, TP410625).
1.02	Disassembly/reassembly information for enclosures and paper handling parts is provided in the following paragraphs:		1.09	Some parts that are not listed in the parts index are shown as necessary to the disassembly procedures such as screws, ring retainers, etc. Most of these parts are common to other Teletype Corporation product lines and, if needed, may already be available in field repair kits or can be ordered.

1.10 The keyboard circuitry can be damaged by static discharge. The 346392 static discharge ground strap is available for use by service personnel. Maintenance spares are provided in antistatic bags which should be saved for reuse when returning components for repair.

1.11 Containers and packing materials retained from maintenance spares should be saved and reused when returning defective components for repair.

1.12 Adjustment information is provided in Printer Adjustments and Spring Tensions, Page 2-6 and Paper Handling and Enclosures, Adjustments, Page 5-1.

2. TOOLS REQUIRED

2.01 The following tools may be required when performing the terminal disassembly/reassembly procedures. Most of these items should normally be present in standard maintenance tool kits.

<u>Part No.</u>	<u>Tools</u>
129534	Wrench, Open End, 3/16 Inch and 1/4 Inch
348097	Nut Driver, 1/4 Inch Socket
348098	Nut Driver, 5/16 Inch Socket
95368	Screwdriver, 1/8 Inch, 2 Inch Blade
100982	Screwdriver w/clip 1/4 Inch, 6 Inch Blade
346392	Strap, Static Discharge
407326	Extractor, I.C.

Customer Supplied

Humiseal Type 1A27  
130Z Aerosol Can or One Quart Container

3. DISASSEMBLY/REASSEMBLY

KP SET PEDESTAL BASED

3.01 To remove the KP set from the pedestal (Pedestal Based):

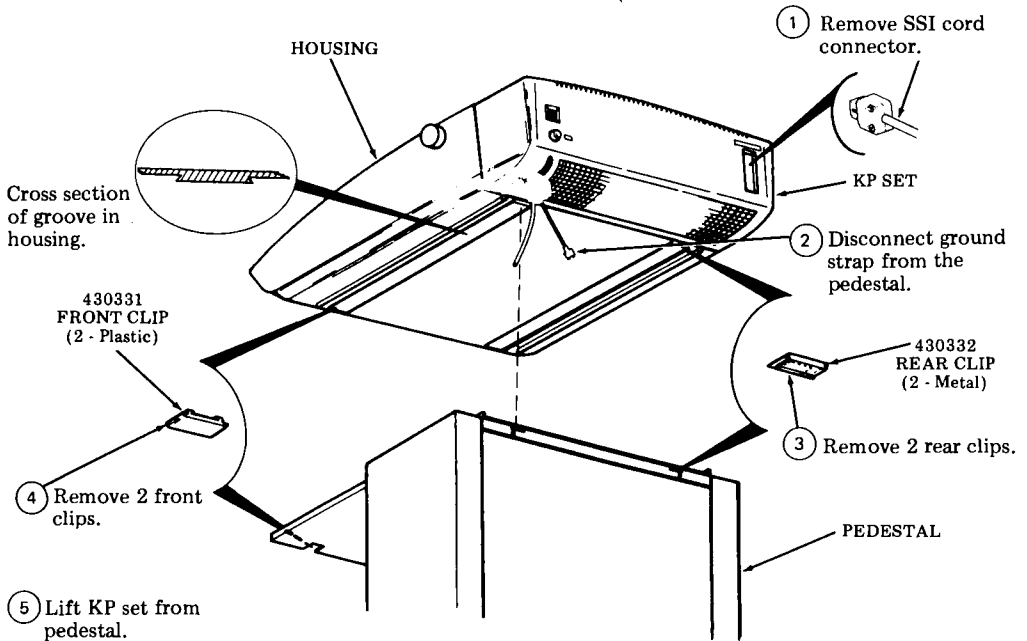

(Rear View)

G. DISASSEMBLY/REASSEMBLY (Contd)

3. DISASSEMBLY/REASSEMBLY (Contd)

PT UNIT PEDESTAL BASED ASR

3.02 To remove the PT unit from the pedestal:

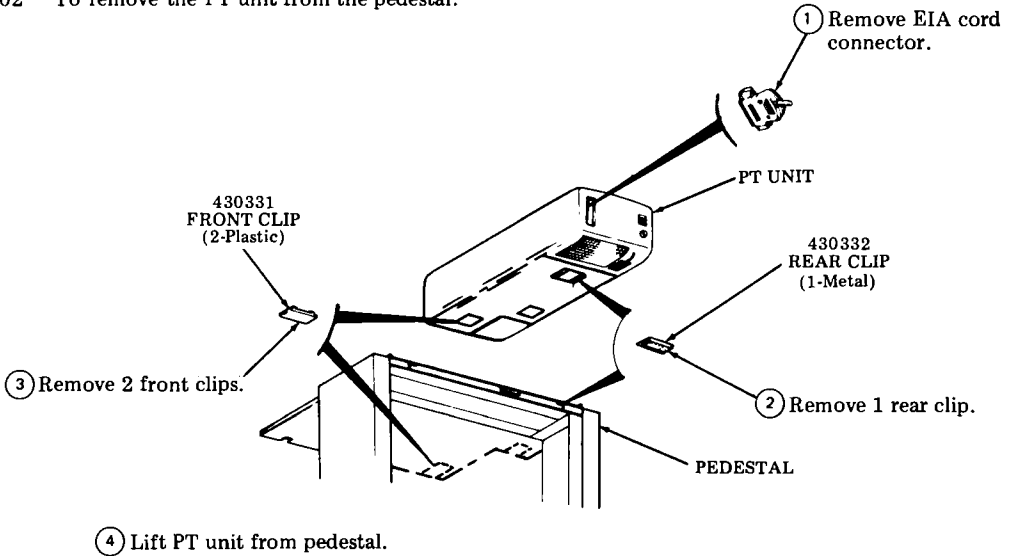

SSI INTERFACE CIRCUIT CARD OR CONTROLLER CIRCUIT CARD ASSEMBLY

3.03 To remove the SSI interface circuit card or controller card assembly:

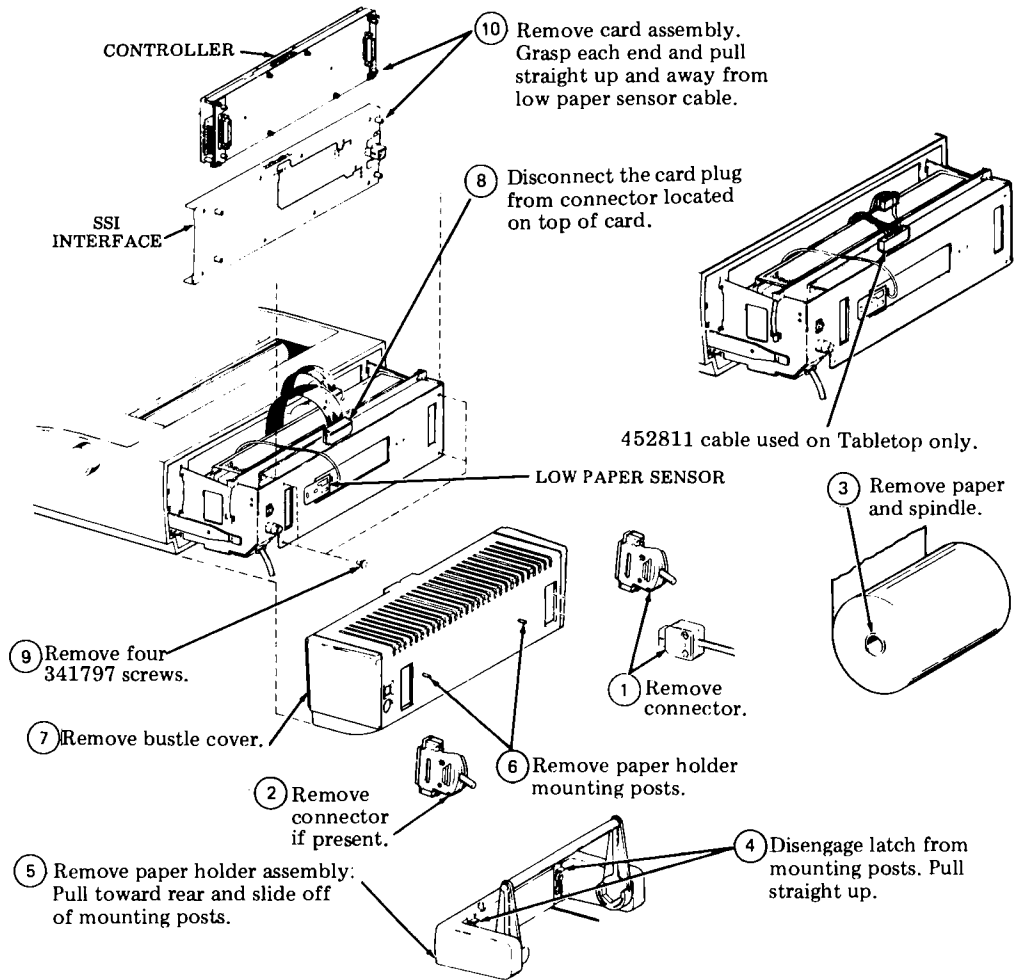

*Note:* In reassembly, align low paper sensor mounting hole with mounting hole in rear frame.

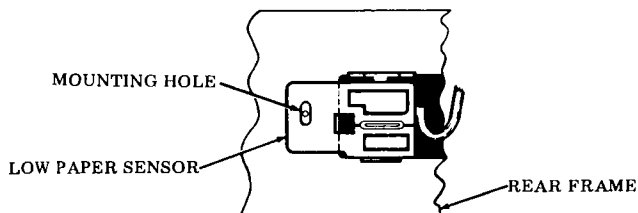

G. DISASSEMBLY/REASSEMBLY (Contd)

3. DISASSEMBLY/REASSEMBLY (Contd)

430700 POWER SUPPLY

3.04 To remove power supply:

- ① Remove paper holder and bustle cover. Perform 3.03, Steps 1 through 7.

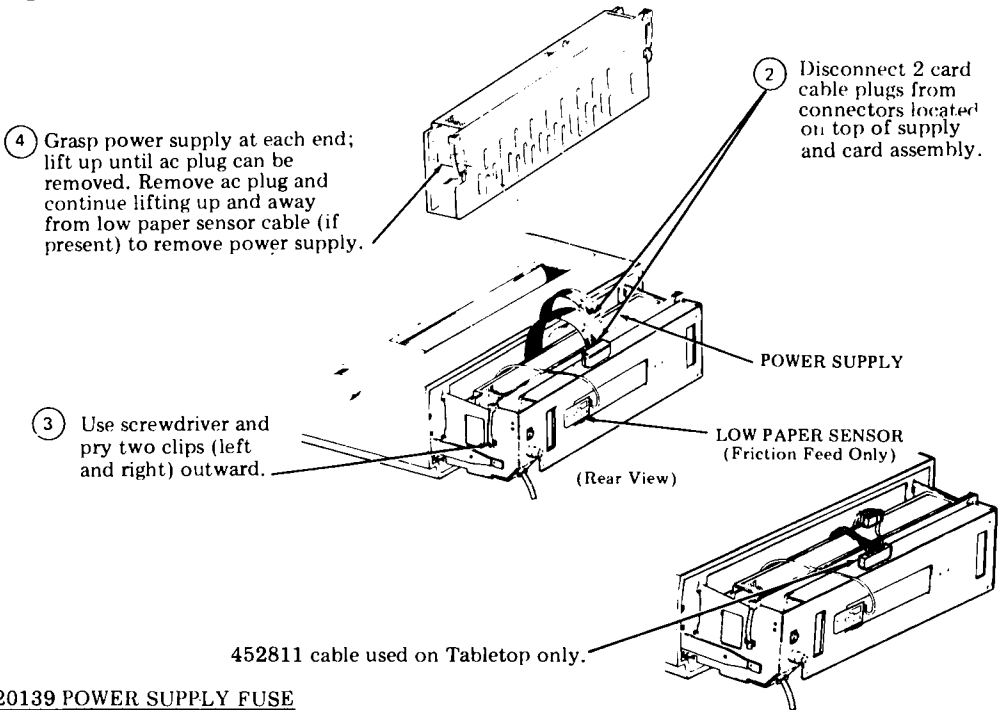

120139 POWER SUPPLY FUSE

3.05 To remove the power supply fuse:

- ① Remove paper holder and bustle cover. Perform 3.03, Steps 1 through 7.

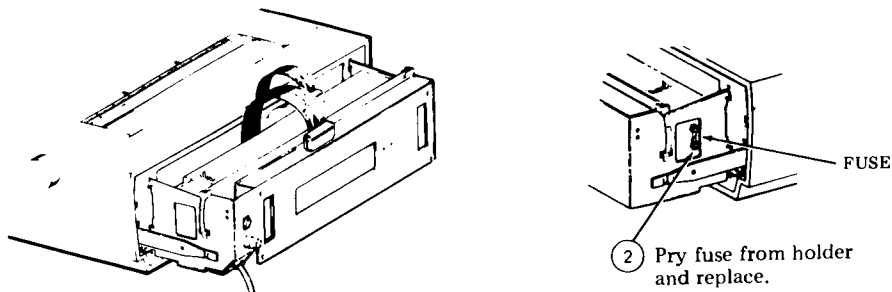

43K202/GAC or 43K202/GAD KEYBOARD

3.06 To remove the keyboard:

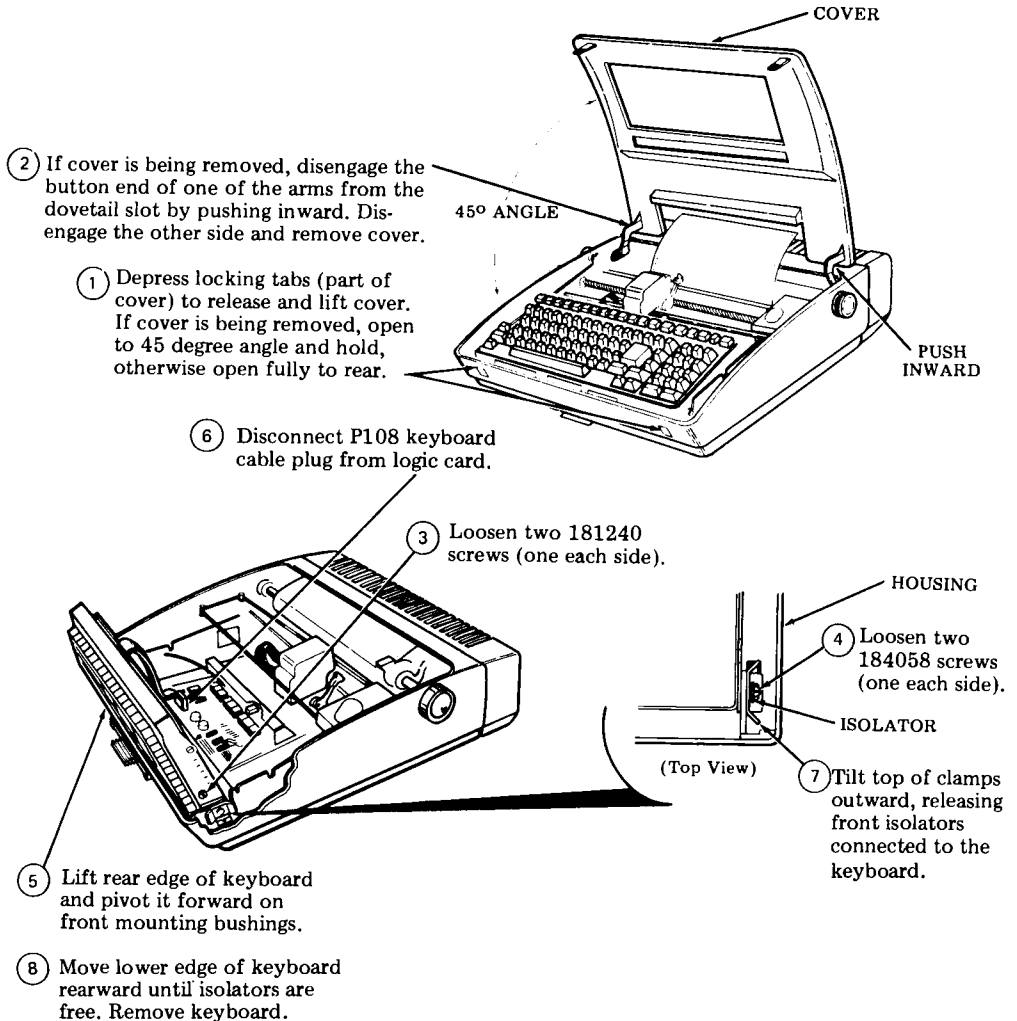

*Note 1:* In reassembly, perform the **KEYBOARD TO COVER ALIGNMENT** adjustment.

*Note 2:* When replacing the cover or indicator scale, perform the **COLUMN INDICATOR POSITIONING** adjustment.

*Note 3:* Loose keyboards are shipped with 181240 screws and 346397 isolators furnished in a loose envelope. These parts must be assembled to the keyboard before installing into the printer side frames.



G. DISASSEMBLY/REASSEMBLY (Contd)

3. DISASSEMBLY/REASSEMBLY (Contd)

143307 LOGIC CARD FUSE

3.07 To remove the logic card fuse:

- ① Remove paper holder and bustle cover. Perform 3.03, Steps 1 through 7.

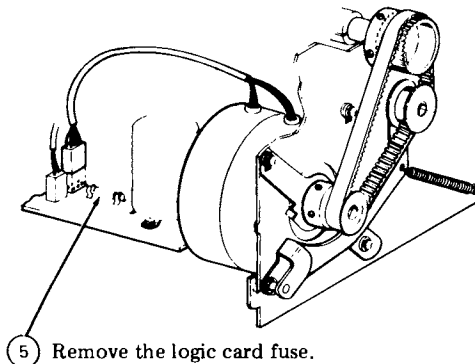
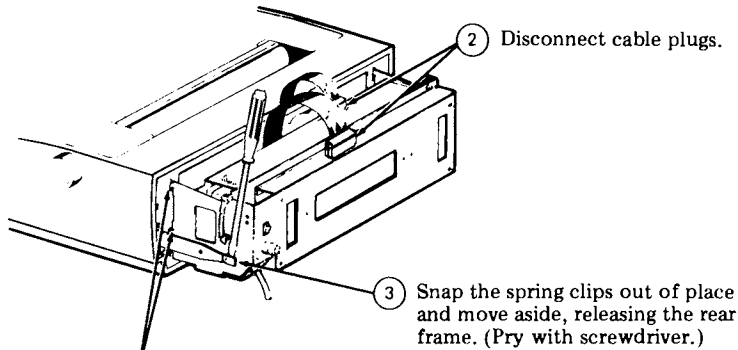

(Rear View)

410745 LOGIC CARD

3.08 To remove the logic card:

② Remove the keyboard.  
(Perform 3.06, Steps 1 through 8.)

① Remove the rear frame assembly.  
(Perform 3.07, Steps 1 through 4.)

③ Move print head and carriage fully to the right.

④ Grasp each end of the logic card front cover and push outward on the sides until the locking tabs are free of the logic card.

⑤ Slowly rotate cover rearward until extension on cover aligns with locking hole in side frame. Apply slight leftward pressure until the extension engages the hole in the side frame, locking the cover into position.

⑥ Disconnect bell cable from logic card.

⑦ Disconnect the following plugs located on the logic card:

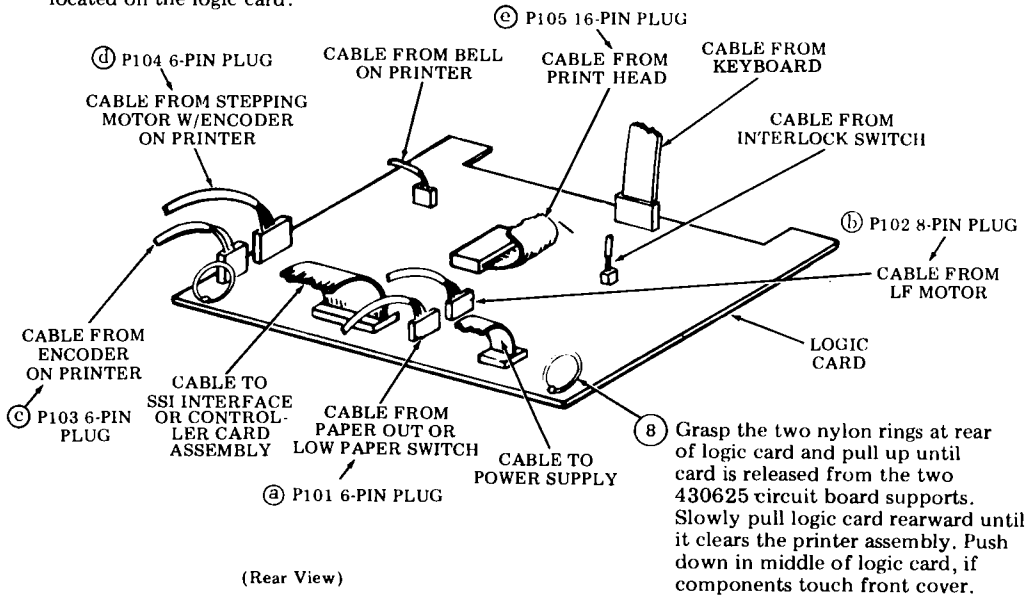

G. DISASSEMBLY/REASSEMBLY (Contd)3. DISASSEMBLY/REASSEMBLY (Contd)PRINTERA. Removal

3.09 To remove the printer:

- ① Remove cover. (Perform 3.06, Steps 1 and 2.)

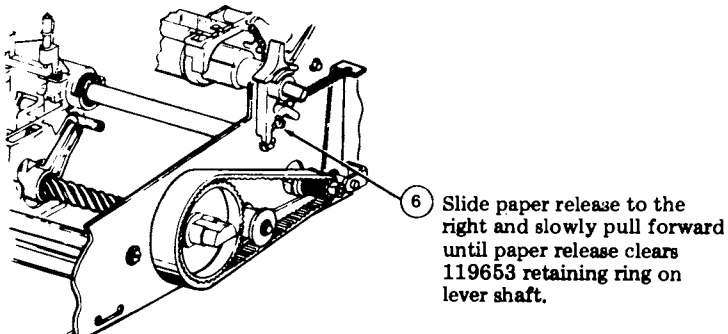
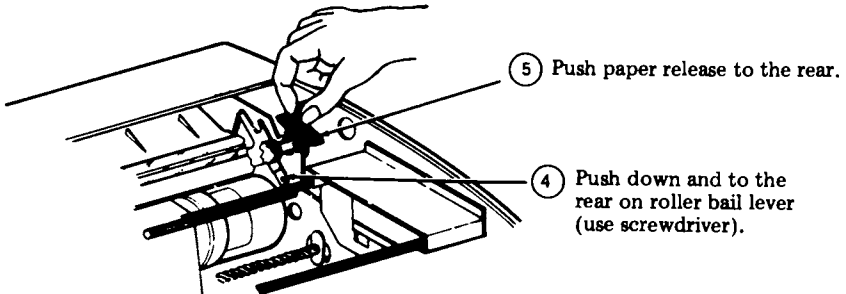
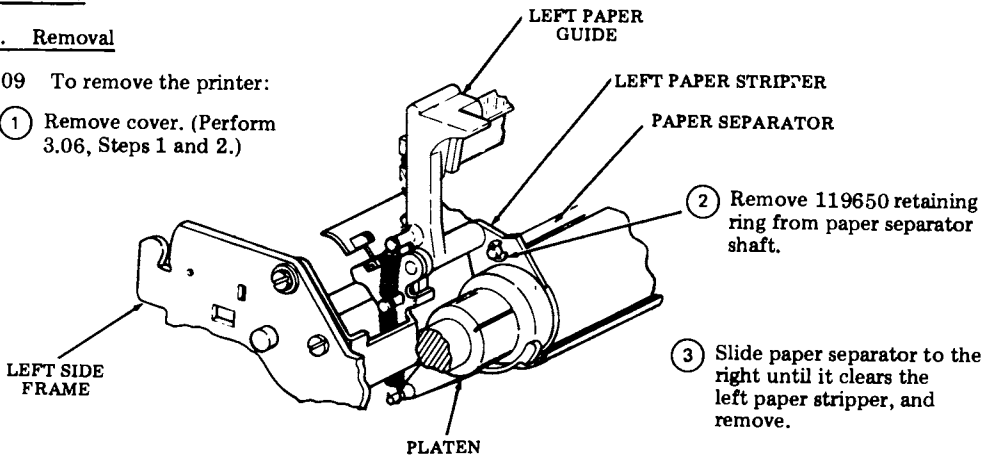

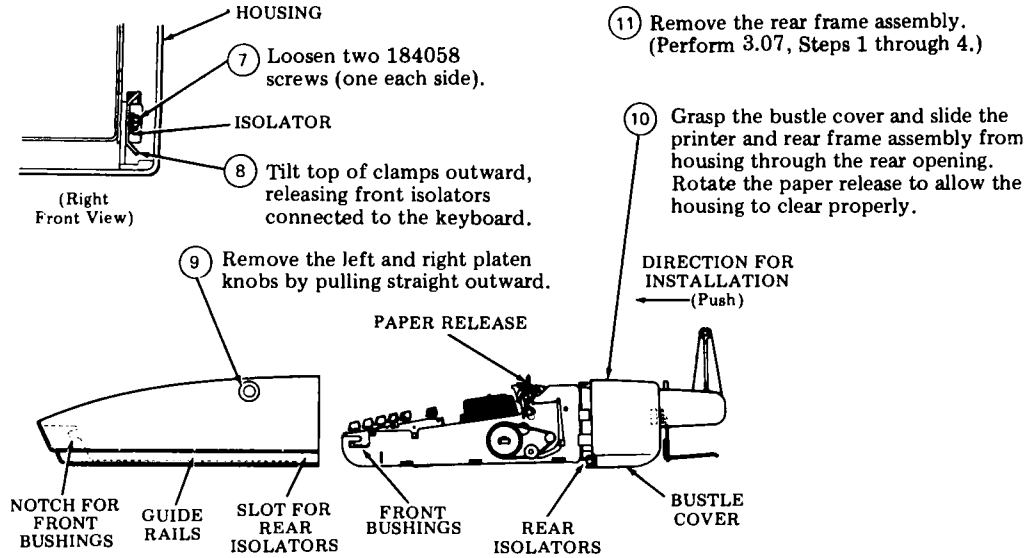

**B. Replacement**

3.10 To replace the printer:

- 1 Install the operator console, if previously removed.
- 2 Install the rear frame assembly and bustle cover.
- 3 Push the printer and rear frame assembly into the housing through the opening in the rear of the housing. There are two molded guide rails in the bottom of the housing to steer the assembly into position.
- 4 Lock the printer and rear frame assembly into position. Insert a screwdriver into the square hole in the nut plate and gently twist (or pry) the screwdriver with enough force to draw the assembly forward.

*Caution: Do not overtwist the screwdriver.*

- 5 Tighten the clamp screws.

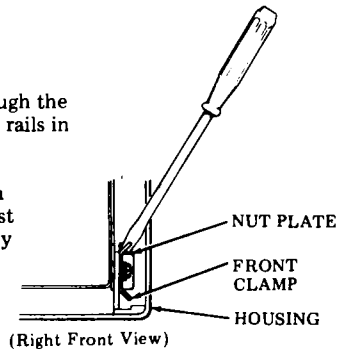

*Note:* The two front clamps should be loosely fastened to the nut plate before the assembly is pushed into the housing. Position each clamp so that the front bushings (keyboard) protrude through the large holes in their respective clamps.

- 6 Replace the paper separator and platen knobs.
- 7 Replace the paper release.
- 8 Replace the cover.
- 9 Perform the KEYBOARD TO COVER ALIGNMENT adjustment.

G. DISASSEMBLY/REASSEMBLY (Contd)3. DISASSEMBLY/REASSEMBLY (Contd)430850 PRINT HEADA. Removal

3.11 To remove the print head:

*Caution: When handling loose print heads, care must be taken to prevent print head cable connector pins from being bent.*

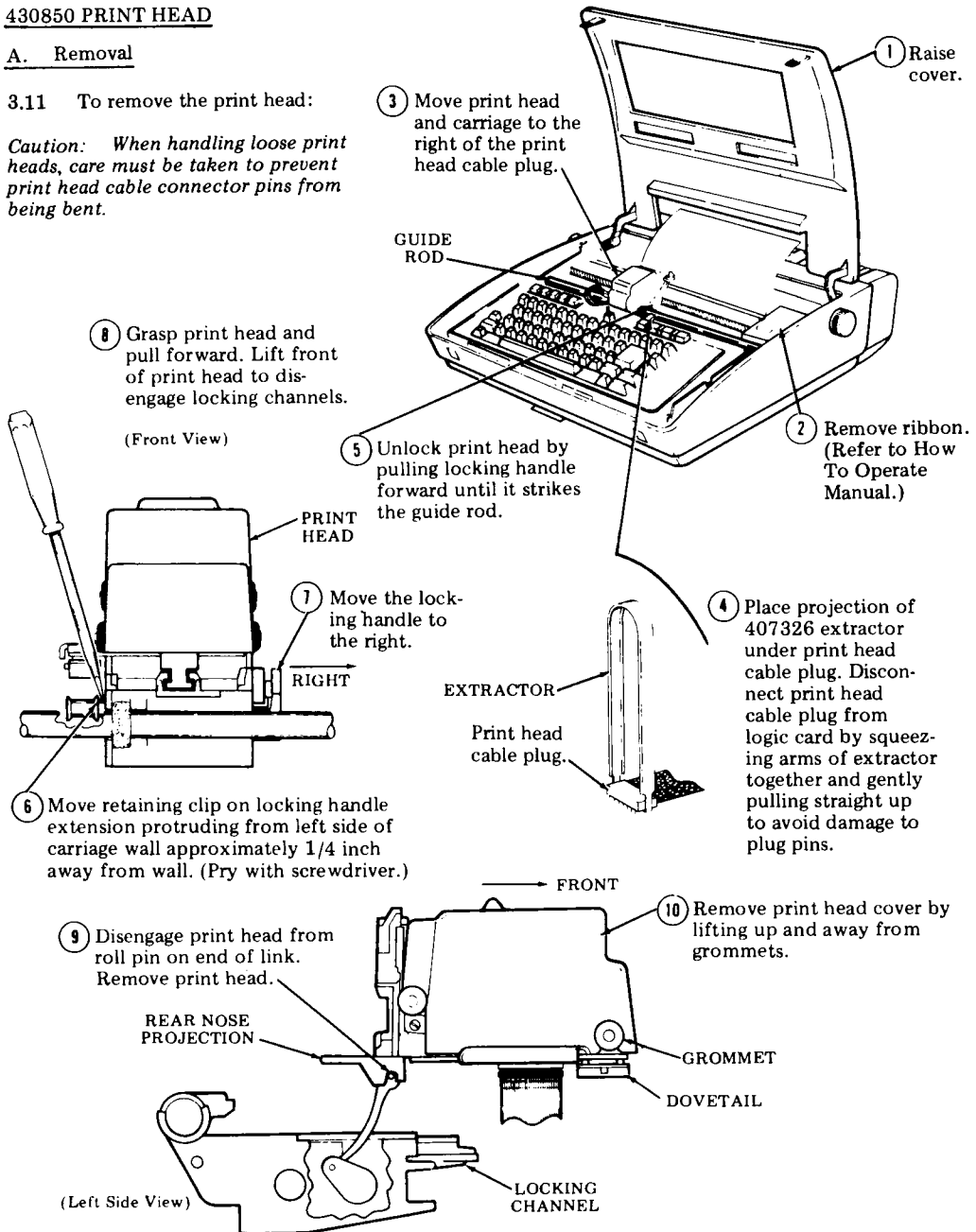

**B. Replacement**

**3.12 To replace the print head:**

*Caution: When handling loose print heads, care must be taken to prevent print head cable connector pins from being bent.*

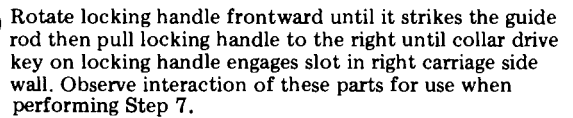
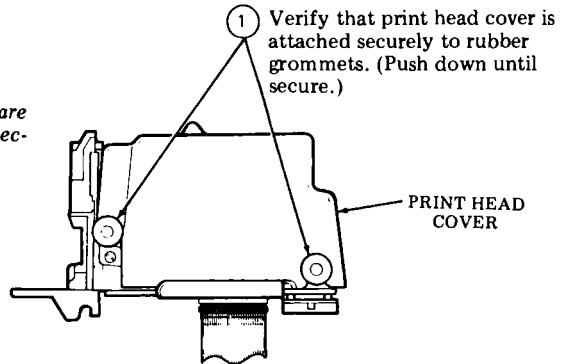
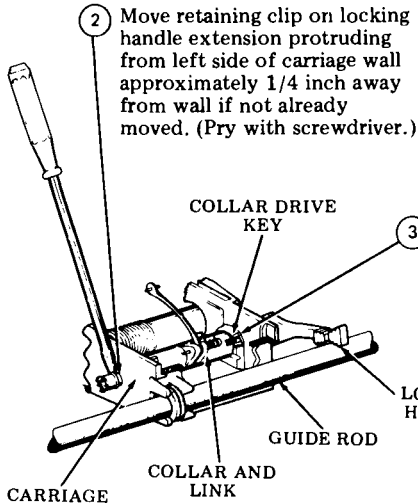

*Note:* Collar and link may snap rearward.

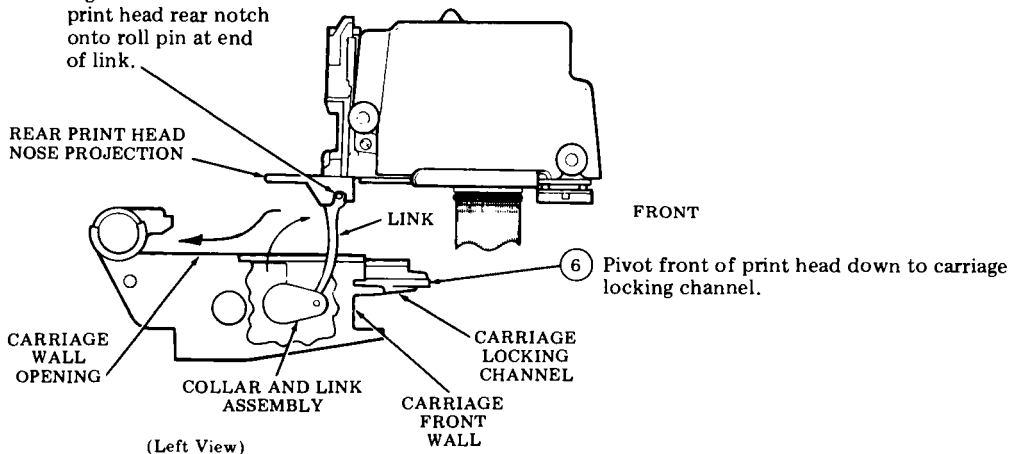
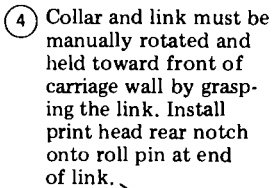
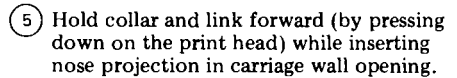

G. DISASSEMBLY/REASSEMBLY (Contd)

3. DISASSEMBLY/REASSEMBLY (Contd)

B. Replacement (Contd)

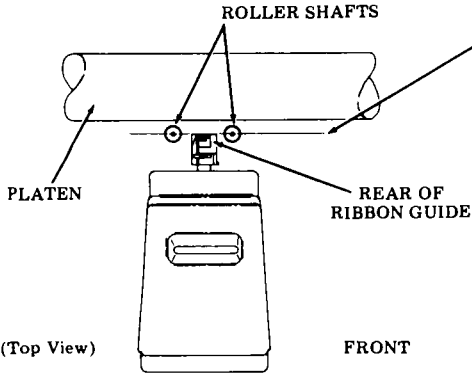

7 Slowly push print head rearward and further into the carriage locking channel until the rear of the ribbon guide is even with center of roller shafts. Apply continuous leftward pressure to locking handle at its pivot shaft, while slowly pulling print head forward until collar drive key on handle engages (snaps) into slot in collar.

*Note:* Parts referred to were visible in Step 3.

(Top View)

FRONT

9 Position and hold print head and carriage assembly to right side of printer and use a 5/16 inch socket wrench to push clip against carriage wall.

8 Move the handle all the way to the rear, locking the print head in close proximity to the platen by the additional force necessary to detent the handle. If handle does not move to rear, the drive key did not properly engage the collar slot (Step 7).

*Note:* Check to make sure there is some clearance between print head and platen before detenting handle. Check PRINT HEAD TO PLATEN adjustment.

(Front View)

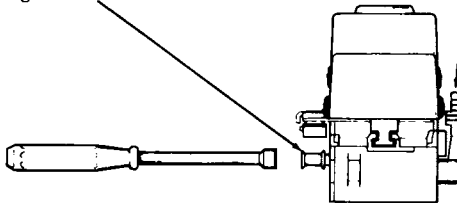

10 Check that no connector pins are bent and carefully connect the print head cable plug to the logic card. Make sure cable does not touch left side frame when the carriage moves fully left.

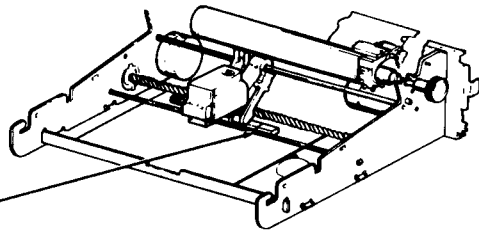

11 Install ribbon.  
(Refer to How To Operate Manual.)

CONTROLLER CIRCUIT CARDS (Pedestal Based)

3.13 To remove plug in circuit cards from the controller:

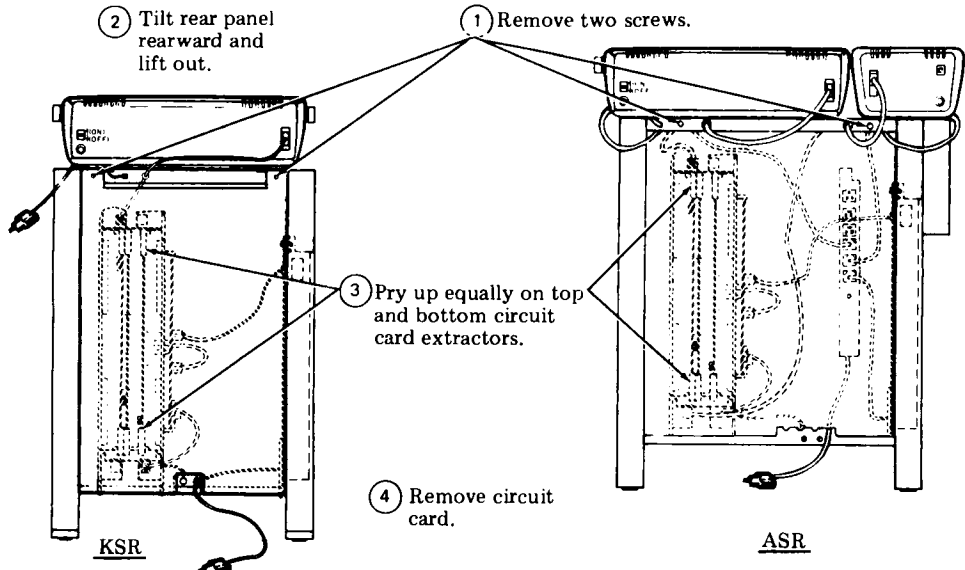

*Note:* In replacing circuit card be sure card is in guide slot and push in equally on top and bottom of circuit card. Make sure card is fully seated.

3.14 To remove the 410756 circuit card from the controller:

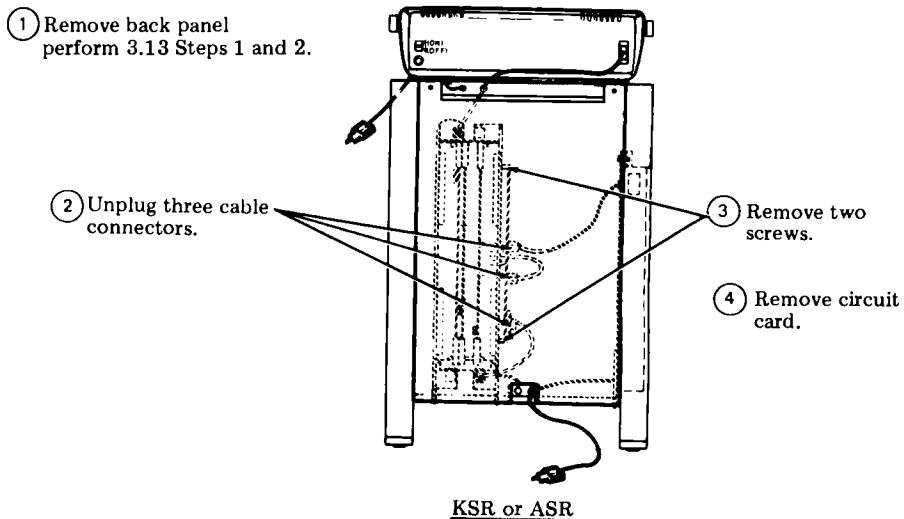



G. DISASSEMBLY/REASSEMBLY (Contd)

3. DISASSEMBLY/REASSEMBLY (Contd)

CONTROLLER (Pedestal Based)

3.15 To remove the controller from the pedestal:

- ① Remove back panel.  
Perform 3.13 Steps 1 and 2.

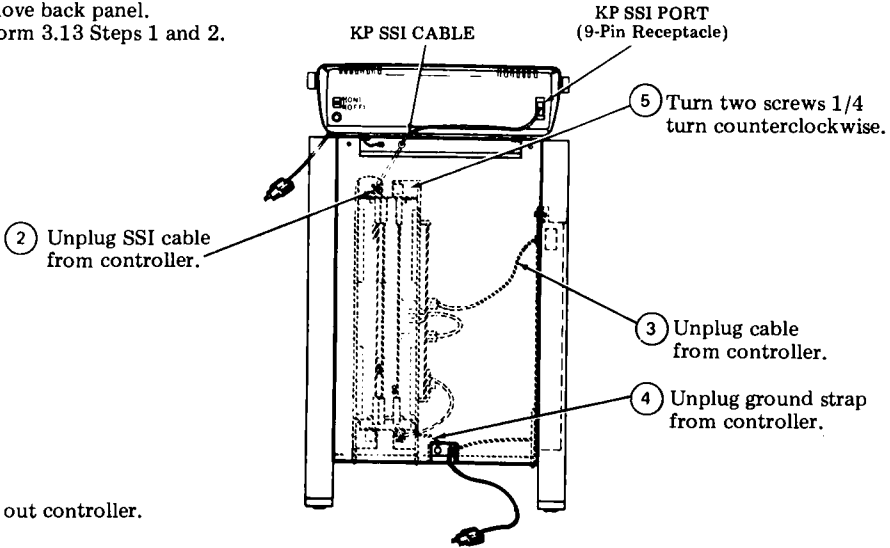

- ⑥ Lift out controller.

KSR

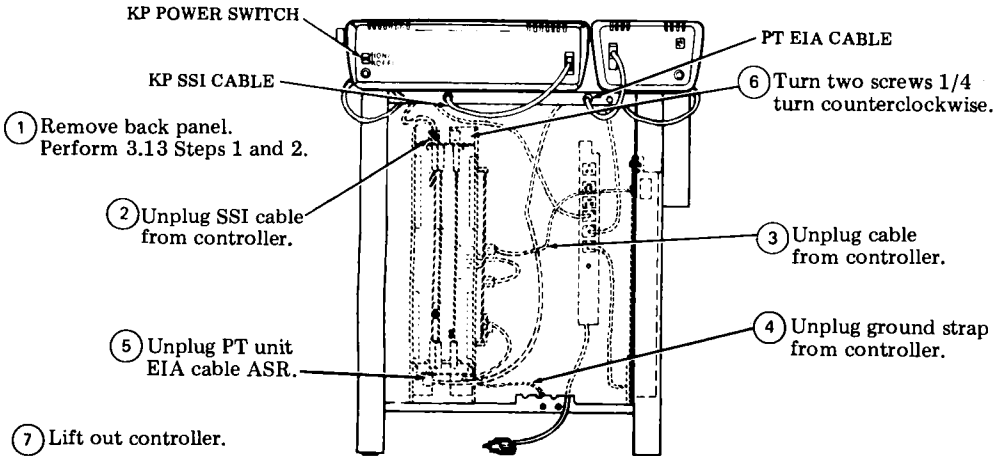

ASR

*Note 1:* In reassembly make sure tabs on controller are seated in slots in pedestal floor.

*Note 2:* If a new controller is being installed, the eight 124516 grommets supplied with the controller should be placed on the controller feet before assembling the controller to the pedestal.

430770 POWER SUPPLY (Pedestal Based)

3.16 To remove the power supply from the pedestal:

- ① Remove back panel. Perform 3.13 Steps 1 and 2. ⑥ Lift out power supply.

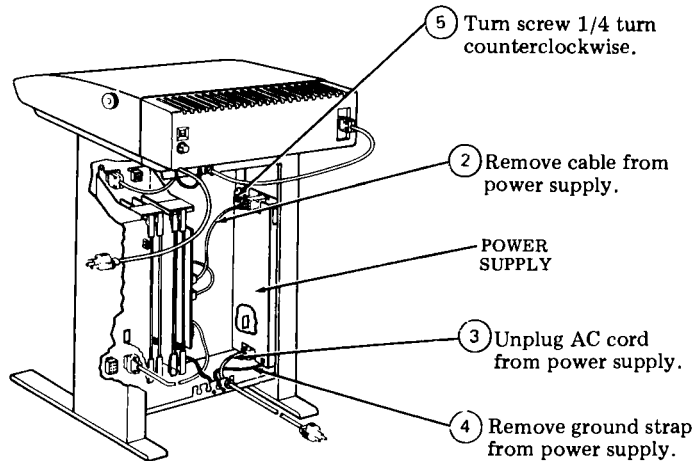
KSR OR ASR

*Note:* In reassembly make sure tabs on power supply are seated in slots in pedestal floor.

307218 POWER SUPPLY FUSE (Pedestal Based)

3.17 To remove power supply fuse:

- ① Remove 430770 power supply. Perform 3.16 Steps 1 through 6.

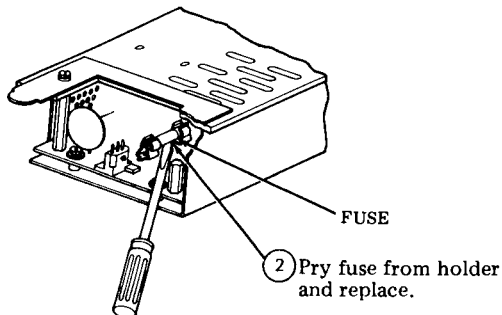

G. DISASSEMBLY/REASSEMBLY (Contd)3. DISASSEMBLY/REASSEMBLY (Contd)406099 BATTERY (Pedestal Based)A. Removal

3.18 To remove the battery:

- ① Remove back panel and the 410705 circuit card. Perform 3.13 Steps 1 through 4.

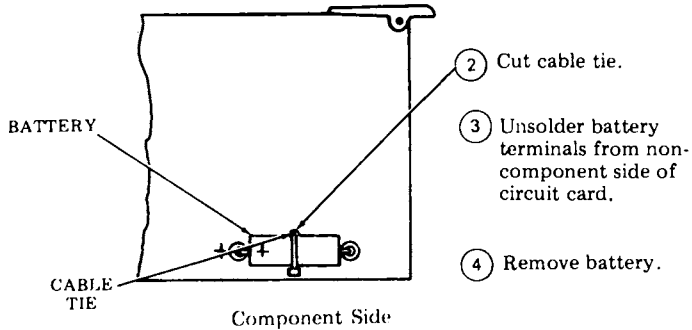
B. Replacement

3.19 To replace battery:

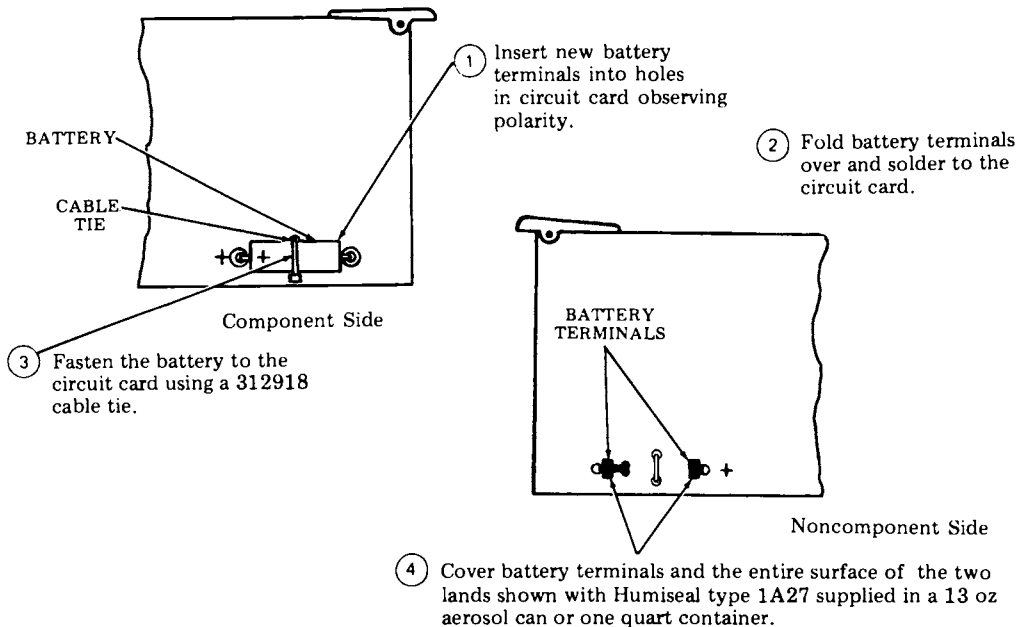

406099 BATTERY (Tabletop)A. Removal

3.20 To remove the battery:

- ① Remove controller card assembly. Perform 3.03, Steps 1 through 10.
- ② Remove eight 410761 mounting screws (do not remove end shield). Retain the two flat washers between the end shield and circuit board shield.
- ③ Slide the circuit board shield and the circuit board to the left until they clear the end shield.
- ④ Remove the circuit card shield. (Note the eight 411118 fiber washers between the shield and the circuit card. Retain these for reassembly).
- ⑤ Open the controller cards as shown.
- ⑥ Cut cable strap.
- ⑦ Unsolder battery terminals from non component side of circuit card.
- ⑧ Remove battery and retain washers.

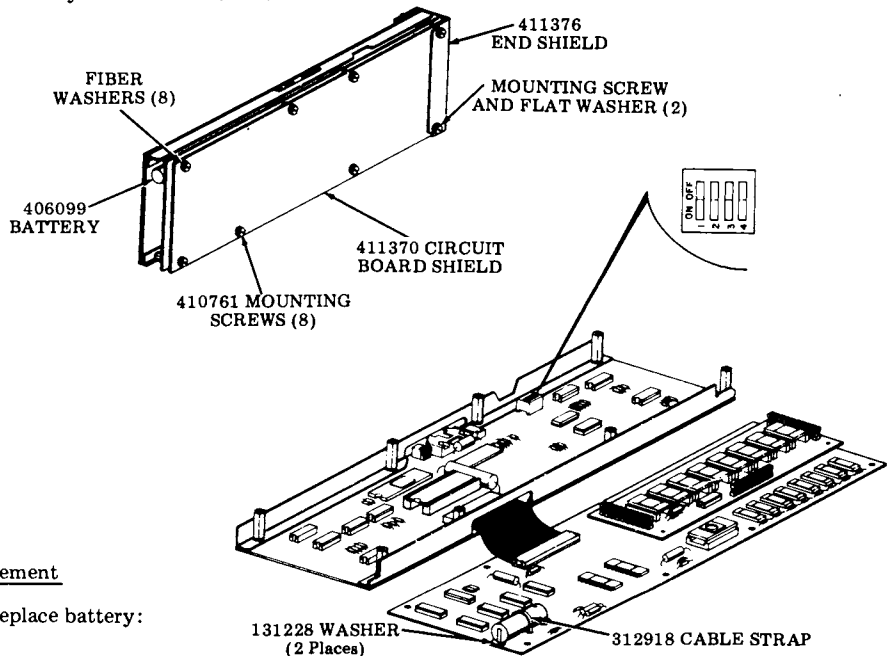
B. Replacement

3.21 To replace battery:

- ① Place washers on battery terminals. Insert terminals into holes in circuit card observing polarity (+ to center of card).
- ② Fold battery terminals over lands and solder to circuit card.
- ③ Fasten the battery to the circuit card using a 312918 cable strap.
- ④ Cover battery terminals and entire surface of the two lands with Humiseal type 1A27 supplied in a 13 ounce aerosol can or a one quart container.
- ⑤ Install mounting screws, washers and shield (if present) and install controller assembly.

G. DISASSEMBLY/REASSEMBLY (Contd)

3. DISASSEMBLY/REASSEMBLY (Contd)

411959 CARD ASSEMBLY, PROGRAM

3.22 To remove the card:

- ① Remove controller card assembly. Perform 3.20, Steps 1 through 5.
- ② Carefully remove the applications program card.
- ③ Assemble the applications program card. (Place over interconnecting pins and carefully push down).
- ④ Reassemble controller card assembly.

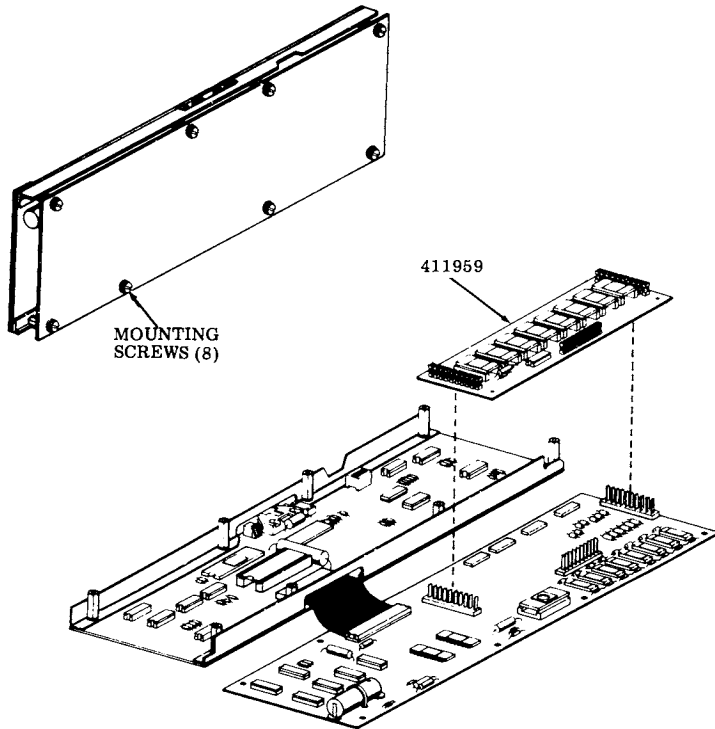

H. ROUTINE MAINTENANCE

<u>CONTENTS</u>	<u>PAGE</u>
1. GENERAL . . . . .	1-111
2. VISUAL CHECKS. . . . .	1-111
3. LUBRICATION . . . . .	1-111
4. CLEANING AND APPEARANCE . .	1-111

1. GENERAL

1.01 This part provides routine maintenance procedures for the 42 Buffered KSR and ASR Teleprinter.

1.02 A routine maintenance should be performed, at the convenience of the customer, at least once a year.

1.03 Routine maintenance consists of visual checks, lubrication, and cleaning. When performed at routine intervals, the possibility of later troubles will be reduced.

1.04 Following the routine maintenance, a local and on-line installation checkout should be performed. (See Page 1-63.) The routine maintenance data should be filled out on the bottom side of the directory card holder.

2. VISUAL CHECKS

2.01 The following areas should be checked for mechanical condition:

- (a) Frayed belts on spacing and line feed motors and on PT unit (ASR) motor.
- (b) Worn or frayed ribbon.

(c) All cable connectors fully seated.

(d) Print head cover fully seated.

3. LUBRICATION

3.01 Lubrication of the printer is required during routine maintenance. Refer to Page 2-18 for type, location, and amounts of lubrication.

3.02 Lubrication of the PT unit is required during routine maintenance. Refer to PT Unit Service Manual, 422.

4. CLEANING AND APPEARANCE

4.01 Examine exterior areas for smudges, dust, etc.

4.02 Check proper fit of cover. Replace extremely damaged or discolored cover, housing, bustle, etc.

4.03 Exterior cleaning should normally be limited to wiping with a soft cloth moistened with a mild detergent. However, in case of ink stained plastic surfaces, a waterless (nonabrasive) hand cleaner or a lather from abrasive bar soap applied with a cloth should be used.

4.04 Interior areas should be examined with the cover opened and accumulations of paper dust, tape dust or ribbon fragments cleaned by carefully brushing loose material onto a cloth. Ink stains or deposits on interior surfaces, ribbon rollers, platen, etc, can be wiped with a cloth dampened in mineral spirits.

*Warning: Do not allow solvents to contact exterior plastic surfaces.*

I. PARTS

	<u>CONTENTS</u>	<u>PAGE</u>
1.	GENERAL .....	1-112
2.	PARTS (Pedestal Based) .....	1-112
3.	NUMERICAL INDEX (Pedestal Based) .....	1-113
4.	PARTS (Tabletop) .....	1-114
5.	NUMERICAL INDEX (Tabletop).....	1-114

1. GENERAL

1.01 Information on maintenance spare parts is provided in this part for the 42 Buffered KSR and ASR Teleprinter.

1.02 This part is provided to identify the Teletype Corporation part number and location of recommended spares that should be available and may be required to correct a trouble.

1.03 Parts for the PT unit can be found in Service Manual 422.

1.04 Part numbers are listed in the index in numerical order and indicate the page on which the parts appear. Asterisked numbers, stocked as "List 1", indicate a maintenance spare stocking ratio of one spare for the first twenty stations and an additional spare for each additional 30 stations in a maintenance area. Part numbers without asterisks, stocked as "List 2", indicate that one spare should be available in each maintenance area. Before ordering, verify that a particular spare is applicable to the type of teleprinter in service.

1.05 All ordering part numbers shown in this manual are Teletype Corporation part numbers.

1.06 Troubleshooting, disassembly/reassembly information for these parts are covered on Pages 1-45 and 1-92, respectively.

2. PARTS (Pedestal Based)

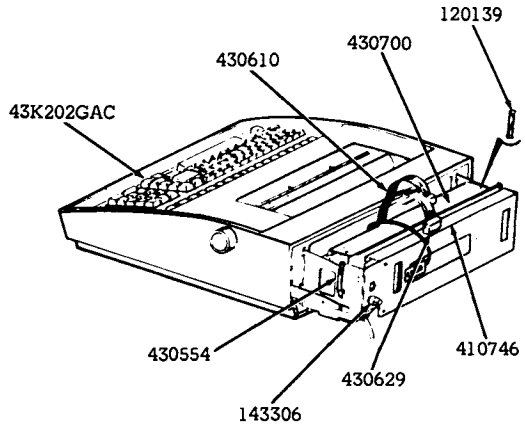
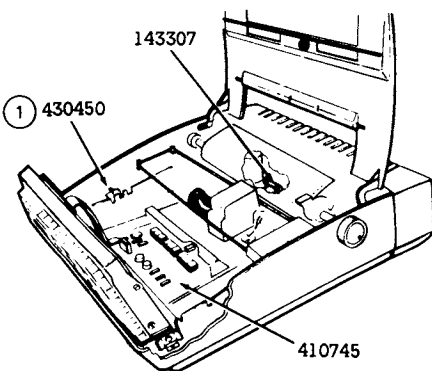

① May be 454623.

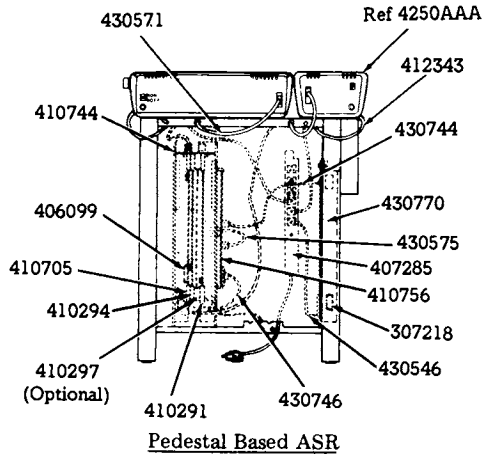
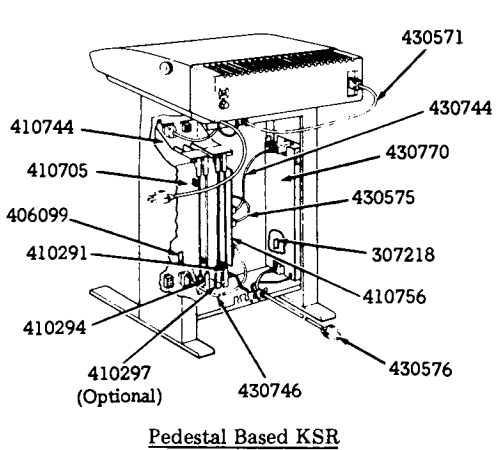

### 3. NUMERICAL INDEX (Pedestal Based)

*Note 1:* One spare should be available in each maintenance area.

*Note 2:* Numbers in parentheses indicate a quantity of parts that is considered one maintenance spare.

<u>Part Number or Unit Code</u>	<u>Description</u>	<u>Page No.</u>
120139*(5)	Fuse 1.0A (KP Power Supply) F2	1-112
143306*(5)	Fuse 1.0A SLO-BLO (R. Frame) F1	1-112
143307*(5)	Fuse 0.6A (L. Card) F3	1-112
307218*(5)	Fuse 1.25A (C. Power Supply) F4	1-113
406099	Battery, 3.6V Nicad	1-113
407285	Panel Assembly AC	1-113
410291*	Card, Circuit CIU/SSI	1-113
410294*	Card, 4K Memory	1-113
410297*	Card, 16K Memory (Optional)	1-113
410705*	Card, IXL/EPROM	1-113
410744	Back Panel	1-113
410745*	Card Logic	1-112
410746*	Card, SSI Interface	1-112
410756*	Card, Telex Interface	1-113
412343	Cable Assembly	1-113
430450*	Switch Assembly, Interlock	1-112
430554(2)	Clip	1-112
430571	Cable, SSI	1-113
430575	Cable	1-113
430576	Cord, Power	1-113
430610	Cable, Power Supply KP	1-112
430629	Cable	1-112
430700*	Power Supply, KP Set	1-112
430744	Cable	1-113
430746	Cable	1-113
430770*	Power Supply, Controller	1-113
454623	Switch Assembly, Interlock	1-112
43K202GAC*	Keyboard	1-112

\*A maintenance spare stocking ratio of one spare for the first twenty stations and one additional spare for each additional 30 stations in a maintenance area.



## I. PARTS (Contd)

## 4. PARTS (Tabletop)

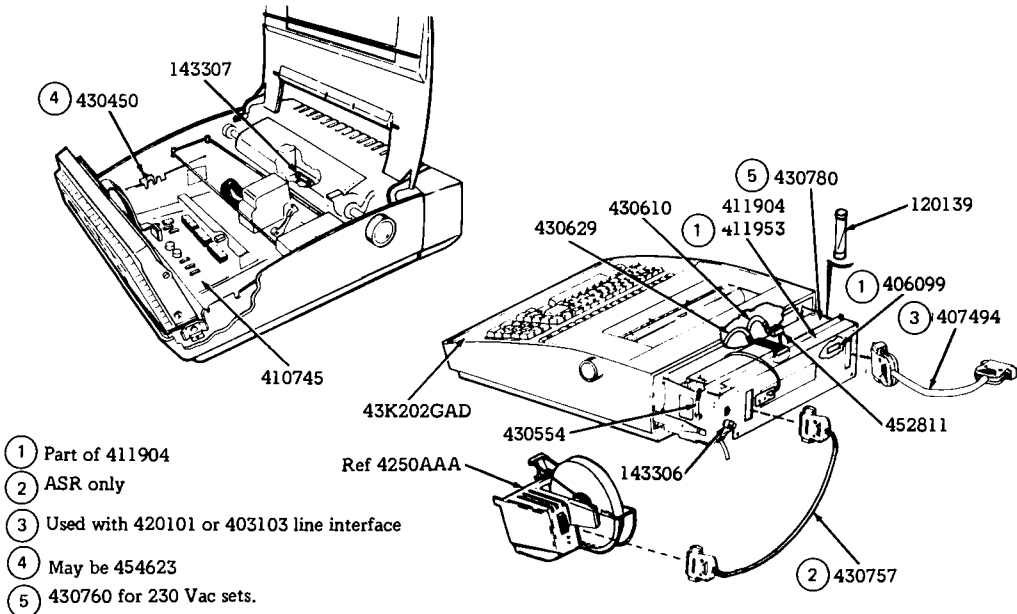

## 5. NUMERICAL INDEX (Tabletop)

Note 1: One spare should be available in each maintenance area.

Note 2: Numbers in parentheses indicate a quantity of parts that is considered one maintenance spare.

Part Number or Unit Code	Description	Page No.
*120139(5)	Fuse 1.0A (KP Power Supply) F2	1-114
*143306(5)	Fuse 1.0A SLO-BLO (R. Frame) F1	1-114
*143307(5)	Fuse 0.6A (L. Card) F3	1-114
406099	Battery, 3.6V Nicad	1-114
407494	Cable, Line Interface	1-114
*410745	Card Logic	1-114
*411904	Card Assembly, 16K	1-114
411953	Card Assembly, Program	1-114
*430450	Switch Assembly, Interlock	1-114
430554(2)	Clip	1-114
430610	Cable, Power Supply	1-114
430629	Cable	1-114
430760	Power Supply	1-114
*430780	Power Supply	1-114
430757	Cable	1-114
*43K202GAD	Operator Console	1-114
452811	Cable Assembly	1-114
454623	Switch Assembly, Interlock	1-114

\*A maintenance spare stocking ratio of one spare for the first twenty stations and one additional spare for each additional 30 stations in a maintenance area.

J. CONVERSIONS — PEDESTAL BASED

<u>CONTENTS</u>	<u>PAGE</u>
1. GENERAL .....	1-115
2. TOOLS REQUIRED .....	1-115
3. CONVERSIONS .....	1-115
A. Changing Memory Size .....	1-115

1. GENERAL

- 1.01 This section provides conversion information for the categories listed in CONTENTS above.
- 1.02 Refer to Teleprinter Disassembly/Reassembly Page 1-92 for component removal and replacement procedures.
- 1.03 After making conversions, an installation checkout should be performed to make sure the station is operable. See Page 1-63.
- 1.04 When ordering replaceable components, unless otherwise specified, prefix each part number with the letters "TP" (ie, TP410324).

2. TOOLS REQUIRED

- 2.01 The following tools are required to make the conversions listed in CONTENTS. These items should normally be present in standard maintenance tool kits.
  - Wrench Open End 3/16" and 1/4" — 129534
  - Pliers, Cutting — 108286
  - Soldering Iron (Low Wattage)
  - Desolderer

3. CONVERSIONS

A. Changing Memory Size

- 3.01 The 42 Buffered KSR or ASR Controller can be configured for 4K or 20K memory size. Refer to the chart below for circuit card part numbers and locations for the various memory sizes.

*Caution: Turn off power before removing or replacing circuit cards.*

- 3.02 If increasing memory size to 20K, strap SI (336470) must be cut on the 410294 circuit card. If decreasing memory size from 20K to 4K, strap SI (336470) must be connected on the 410294 circuit card.

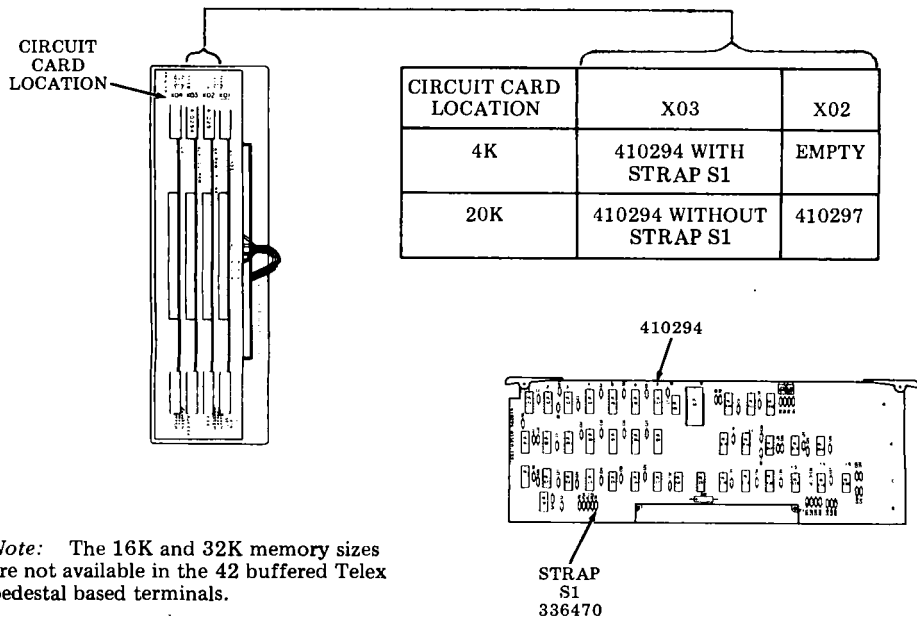

PART 2 — 42 PRINTER

INDEX

PAGE

A. TROUBLESHOOTING .....	2-1
B. WIRING .....	2-4
C. ADJUSTMENTS AND SPRING TENSION .....	2-5
D. LUBRICATION .....	2-14
E. DISASSEMBLY/REASSEMBLY .....	2-18
F. PARTS .....	2-36

PART 2 — 42 PRINTER

A. TROUBLESHOOTING

<u>CONTENTS</u>	<u>PAGE</u>
1. GENERAL .....	2-1
2. TROUBLESHOOTING GUIDE.....	2-1
1. <u>GENERAL</u>	
1.01 This part provides troubleshooting information for the Pedestal Based or Tabletop 42 Printer.	
1.02 Printer troubleshooting is initiated either by 42 Buffered KSR and ASR Teleprinter Troubleshooting or when trouble in the printer is suspected from symptoms observed.	
1.03 Analysis in this part is limited to isolation of the trouble within the printer up to its electrical interface to the logic card. The 42 Printer must be tested as part of a 42 Buffered KSR or ASR Teleprinter. Where analysis indicates the trouble is not in the printer, return to Part 1, Troubleshooting and/or Testing for further analysis.	

- 1.04 When ordering replaceable components, unless otherwise specified, prefix each part number with the letters "TP" (ie, TP410324).
- 1.05 The 430850 print head is returnable to Teletype Product Service Centers for repair.
- 1.06 Isolation and correction of troubles is based on electrical checks, parts replacement or adjustments.

Reference Sections are:

- Page 2-4 Wiring
- Page 2-5 Adjustments and Spring Tensions
- Page 2-18 Disassembly/Reassembly
- Page 2-36 Parts

1.07 Trouble analysis is presented in the form of a "20 Questions" routine in 2. TROUBLESHOOTING GUIDE. The guide, with questions and yes or no columns, should be used always starting with the first question and proceeding according to the "yes" or "no" directive.

2. TROUBLESHOOTING GUIDE

<u>QUESTION</u>	<u>YES</u>	<u>NO</u>
1. Does test message print and paper advance properly while Switch No. 5 is operated on the logic card (interlock switch closed)? See caution below.	Go to 2.	Go to 1a.
1a. Is red lamp on power supply lit?	Go to 1b.	Go to Teleprinter Troubleshooting.

*Caution: Do not operate Switch No. 5 on the logic card with the circuit card shield raised. Operate Switch No. 5 by reaching under the circuit card shield with a non-metallic object.*

## A. TROUBLESHOOTING (Contd)

## 2. TROUBLESHOOTING GUIDE (Contd)

<u>QUESTION</u>	<u>YES</u>	<u>NO</u>
1b. Does anything print or perform?	Go to 1c.	Go to Teleprinter Troubleshooting.
1c. Does carriage space and return properly?	Go to 1d.	<p>Check for mechanical bind by moving carriage manually with power off.</p> <p>Check for proper spacing belt spring tension.</p> <p>Check <u>PLATEN END PLAY</u> adjustment.</p> <p>Check continuity of spacing motor and encoder.</p> <p>Check switch No. 1 on print head.</p> <p>Replace motor and/or encoder or cable.</p> <p>Replace lead screw nut.</p>
1d. Does paper advance properly (successive lines uniformly spaced)?	Go to 1e.	<p>Check line feed belt tension.</p> <p>Check for mechanical bind by rotating platen manually with power off.</p> <p>Check <u>PLATEN END PLAY</u> adjustment.</p> <p>Check <u>LINE FEED FOL-LOWER PULLEY STOP BRACKET</u> and <u>PRESSURE ROLLER BAIL</u> adjustments (friction feed).</p> <p>With power on (reset) check platen detenting through full rotation by turning platen knob.</p> <p>Check continuity of line feed motor.</p> <p>Replace motor or cable.</p>
1e. Are any characters printed?	Go to 1f.	<p>Check continuity of print head and cable.</p> <p>Go to Teleprinter Troubleshooting.</p>

<u>QUESTION</u>	<u>YES</u>	<u>NO</u>
1f. Are any dots missing from printed characters?	Check continuity of associated print magnet.  Check <u>PRINT HEAD ARMATURE</u> adjustment.  Replace print head or cable.	Go to 1g.
1g. Are any dots noticeably out of line on characters with vertical segments?	Replace print head.	Go to 1h.
1h. Is proper print density obtained (good ribbon, proper paper).	Undefined problem during printer test.  Go to Teleprinter Troubleshooting.	Check <u>PRINT HEAD TO PLATEN</u> adjustment.  With power off and carriage moved manually, check that ribbon moves with carriage without slipping during return and does not move when carriage is moved to the right.  Check carriage and left bracket ribbon rollers for "one way" rotation.
2. Did bell ring during <u>PRINTER TEST</u> ?	Go to 3.	Go to 2a.
2a. Does bell ring under any conditions (CTRL G RH margin, etc)?	Go to Teleprinter Troubleshooting.	Check bell coil and cable continuity.  Check for freedom of bell plunger.
3. Does <u>ALARM</u> indicator light when a low paper condition is sensed?	Undefined trouble.  Go to Teleprinter Troubleshooting.	Check continuity of low paper cable and contacts.

B. WIRING

CONTENTS

PAGE

1. GENERAL .....	2-4
2. PRINTER WIRING.....	2-4
1. <u>GENERAL</u>	
1.01 This section provides wiring information for the 42 printer.	
1.02 Related wiring information and cable connections to the logic card are shown on Page 1-56, Wiring.	
1.03 Designations on printer wiring diagrams do not appear on the components.	
1.04 The wiring information in this section is provided to support the 42 Printer Troubleshooting Guide on Page 2-1.	
1.05 When ordering replaceable components, unless otherwise specified, prefix each part number with the letters "TP" (ie, TP410324).	
2. <u>PRINTER WIRING</u>	

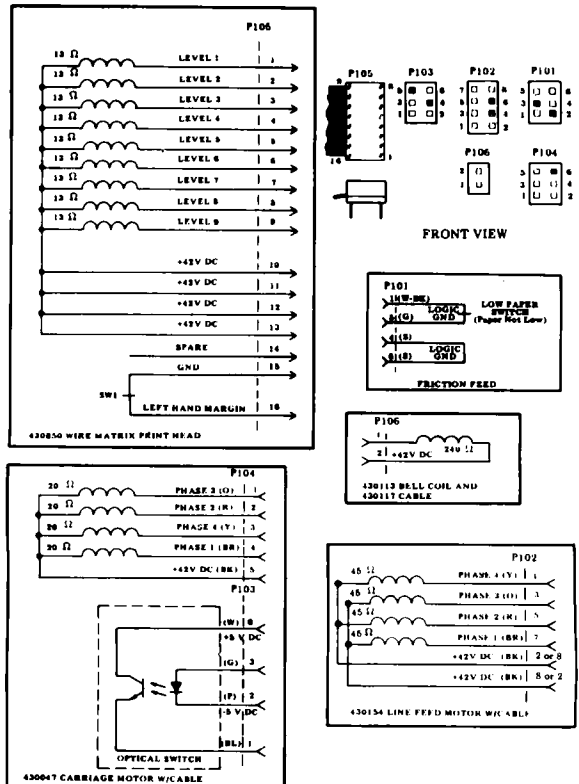

C. ADJUSTMENTS AND SPRING TENSIONS

<u>CONTENTS</u>	<u>PAGE</u>	<u>1. GENERAL</u>
1. GENERAL . . . . .	2-5	1.01 This part provides printer adjustments and spring tensions.
2. TOOLS REQUIRED . . . . .	2-6	1.02 Belt tensions are checked with a spring scale held at the angle shown in the adjustment illustration.
3. PRINTER ADJUSTMENTS . . . . .	2-6	1.03 When ordering replaceable components, unless otherwise specified, prefix each part number with the letters "TP" (ie, TP410324).
LEFT AND RIGHT PAPER GUIDES (Angular Positioning) . . . . .	2-6	1.04 After an adjustment is complete, tighten any screws or nuts loosened to make the adjustment.
LINE FEED FOLLOWER PULLEY STOP BRACKET . . . . .	2-7	1.05 Reference in the procedure to left or right, up or down, and top or bottom, etc, refer to the printer in its normal operating position.
LINE FEED MOTOR BELT TENSION (Floating Motor Only) . . . . .	2-8	1.06 Adjustments should be checked and performed when a trouble indicates a specific adjustment may be out of tolerance or when an adjustment is disturbed to enable a part to be removed or replaced.
PRINT HEAD TO PLATEN . . . . .	2-9	1.07 Spring tension checks should be performed when a trouble indicates a possible defective spring or to verify proper part numbers.
RIBBON CARTRIDGE MAGNETIC LATCH . . . . .	2-9	1.08 Springs that do not meet the tension requirements should be replaced.
PRESSURE ROLLER BAIL . . . . .	2-11	
PLATEN ENDPLAY . . . . .	2-11	
PRINT HEAD ARMATURE . . . . .	2-11	
4. SPRING TENSIONS . . . . .	2-12	
SPRING IDENTIFICATION . . . . .	2-13	



### C. ADJUSTMENTS AND SPRING TENSIONS (Contd)

#### 2. TOOLS REQUIRED

- 2.01 Refer to Maintenance Tools Section 570-005-800TC for a complete listing of various types of hand tools available for maintenance of Teletype Corporation equipment.
- 2.02 The following tools may be required when performing adjustments or spring tension checks. Most of these items should normally be present in standard maintenance tool kits.

#### Tools

Nut Driver, 1/4 Inch	348097
Nut Driver, 5/16 Inch	348098
Gauge Set	117781
Gauge, Tape	95960
Hook, Pull Spring	75765
Hook, Pull Spring	142554
Hook, Push Spring	142555
Scale, Spring (64 Ounce)	82711
Scale, Spring (8 Ounce)	110443
Scale, Spring (32 Ounce)	110444
Scale, 15 Pound Spring	135059
Screwdriver, 3-1/2 Inch Blade	94647
Screwdriver	95368
Screwdriver With Clip	100982
Tweezers	151392
Wrench, Hex Key	124682
Wrench, 3/16 Inch Socket	125752
Wrench, 3/16 Inch and 1/4 Inch Open End	129534
Wrench, 5/16 Inch and 3/8 Inch Open End	152835

#### 3. PRINTER ADJUSTMENTS

##### LEFT AND RIGHT PAPER GUIDES (Angular Positioning)

##### Requirement

The left paper guide should seat fully on the hub. The right paper guide should also be fully seated on the hub and the center paper guide should just touch the platen in the middle.

##### To Adjust

On left side, loosen the two mounting screws friction tight and move the left paper guide mounting bracket to meet the adjustment. With finger pressure applied, tighten screws.

On right side, loosen one mounting screw and with an open end wrench applied to the hex post, rotate bracket until adjustment is met. While holding the post, retighten the screw.

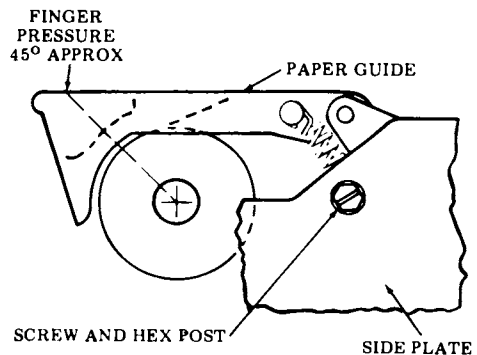

## LINE FEED FOLLOWER PULLEY STOP BRACKET

*Note:* For units with line feed pulleys only.

### Requirement

With the set screws on both pulleys positioned as shown below and with the follower pulley resting on the belt, push the pulley against the belt to take up all friction. Slowly release pressure. Measuring between the follower lever and the adjacent tab of the stop bracket there should be

Min 0.010 inch---Max 0.050 inch  
gap between them.

### To Adjust

Loosen the two mounting screws on the stop bracket to friction tight and move bracket to meet the adjustment. If the motor mounting holes are slotted, the motor may be repositioned from the center of the slot, if necessary, if the stop bracket adjustment does not meet the requirement.

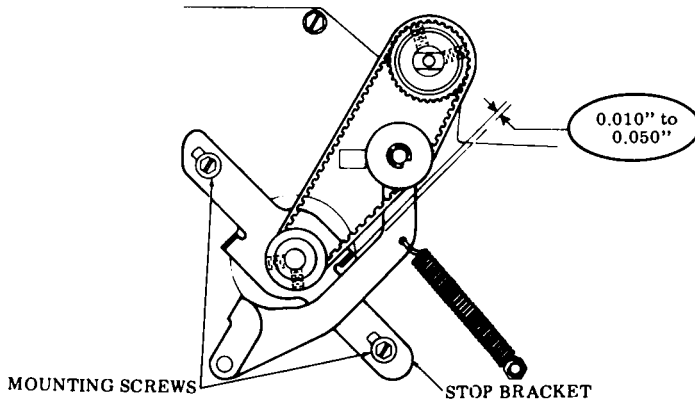

### C. ADJUSTMENTS AND SPRING TENSIONS (Contd)

#### 3. PRINTER ADJUSTMENTS (Contd)

##### LINE FEED MOTOR BELT TENSION (Floating Motor Only)

###### Requirement:

When the belt and sprocket system is at the point of maximum tension as shown (pulley screws facing out), there shall be some clearance between the top of the spacer and the top of the slot. Check by squeezing belt while observing upward motor movement.

When the pulleys are at the point of minimum tension (pulley screws facing in), the distance across the belt shall be a minimum of 5/8 inch with the belt deflected until the motor rises to the top of its free travel (spacer at top of slot).

###### To Adjust:

With the system pulleys set up for minimum tension and the clamping screw loose, press down on the motor to reduce any belt slack, then release. Hold spacer down and tighten screw.

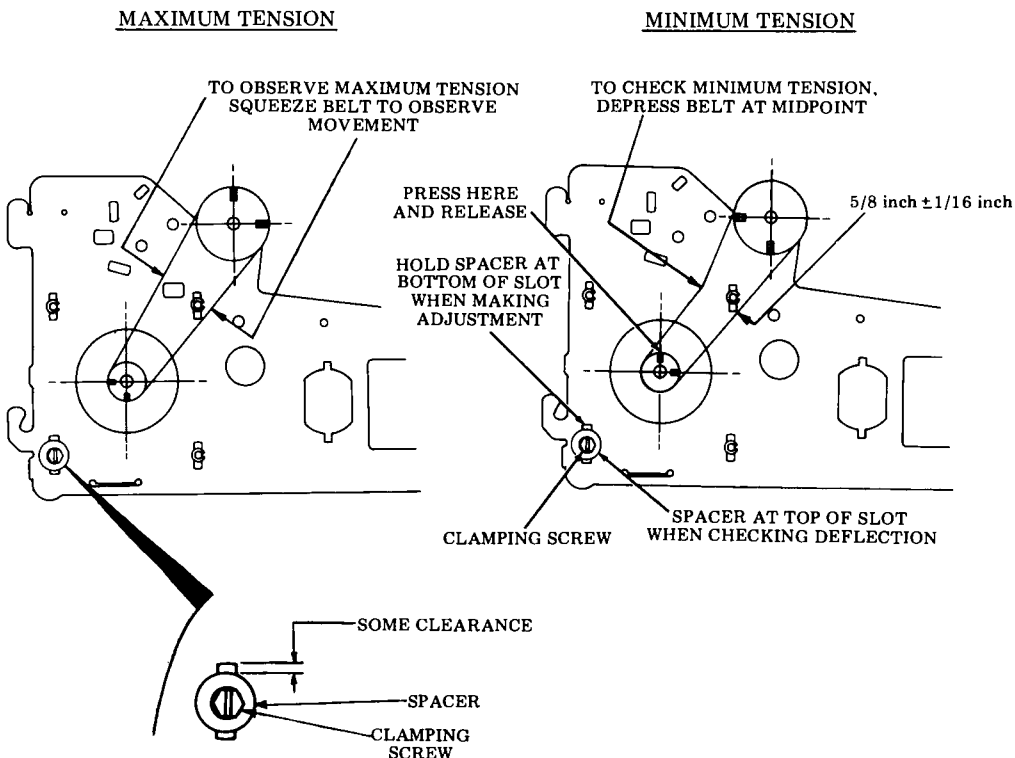

PRINT HEAD TO PLATEN

Requirement

There should be

Min 0.025 inch--Max 0.035 inch

gap between the ribbon guide of the print head and the platen (without paper or ribbon) and at all positions of the carriage and platen, when platen play at the right end is biased down and to the rear and the print head is locked.

To Adjust

Position carriage to the extreme left position. Unlock locking handle, use 1/4 inch "J" wrench to loosen right-hand locknut and with carriage biased rearward, insert 1/4 inch socket wrench through access hole in left side frame and rotate eccentric post to adjust. Tighten locknut. Check adjustment with carriage locked. Check adjustment on extreme right end of platen, while biasing platen down and to the rear. Refine adjustment, if necessary.

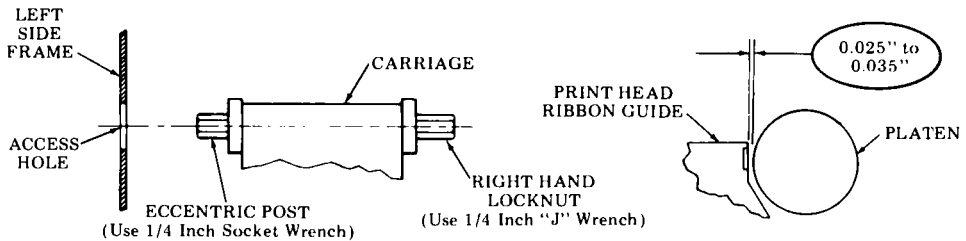

RIBBON CARTRIDGE MAGNETIC LATCH

Requirement

The magnetic pole pieces of the magnetic latch should be firmly engaged with the cartridge lower metal plate when the cartridge is installed in the right-hand cartridge mounting bracket.

To Adjust

Loosen the two magnetic latch mounting screws. Install cartridge onto the mounting bracket. While holding the cartridge down firmly, allow the magnetic latch to fully engage the lower metal plate of the cartridge. Tighten the latch mounting screws.

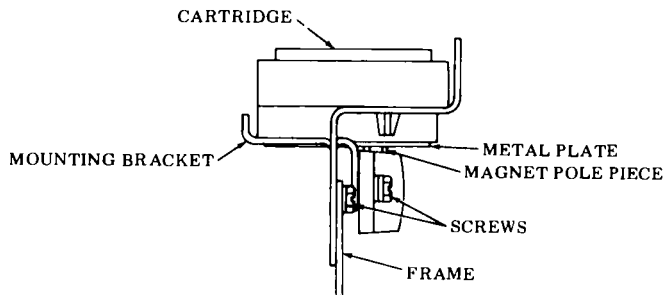

C. ADJUSTMENTS AND SPRING TENSIONS (Contd)

3. PRINTER ADJUSTMENTS (Contd)

PRESSURE ROLLER BAIL

Requirement

With the paper release lever in the forward position and the right end of the carriage next to the right rear carriage wick located immediately under the arm of the pressure roller bail (between the two pressure rollers) there should be from

Min 0.050 inch--Max 0.080 inch

gap between the carriage and the bail arm when measured at the closest point on printers with early design carriage and

Min 0.075 inch--Max 0.105 inch  
with late design carriage.

To Adjust

Loosen the clamp screw to friction tight. Move pry point down to increase gap or up to decrease gap.

Early Design 430215 Carriage Assembly

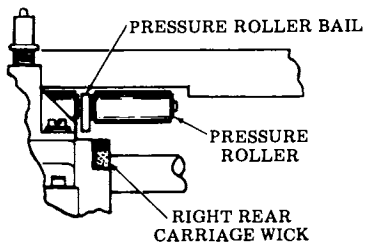

PRESSURE ROLLER

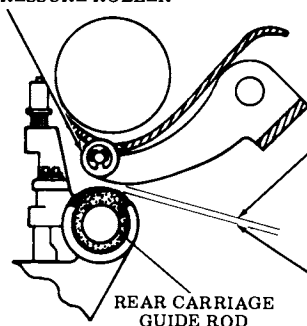

EARLY DESIGN CARRIAGES  
There shall be from 0.050 to 0.080 gap (measured at the closest points).

(Right Side View)

LATE DESIGN CARRIAGES  
There shall be from 0.075 to 0.105 gap (measured at the closest points).

Late Design 430215 Carriage Assembly

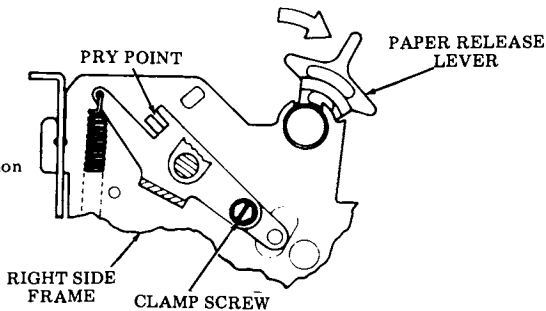
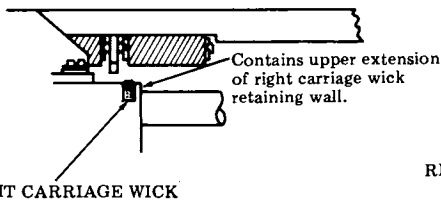

PLATEN ENDPLAY

The following two requirements must be met:

(1) Requirement

Platen Endplay -- With the platen biased to the right, there should be

Min Some --Max 0.008 inch clearance between the left bearing and the platen hub, at the closest point, and

Max 0.030 inch between the left bearing and the pulley at the closest point.

To Adjust

Loosen line feed pulley set screws and position.

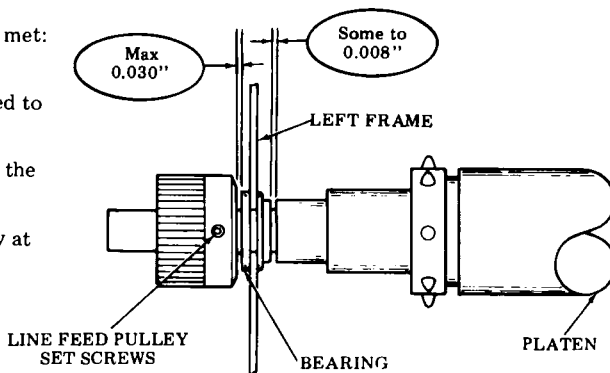

PRINT HEAD ARMATURE

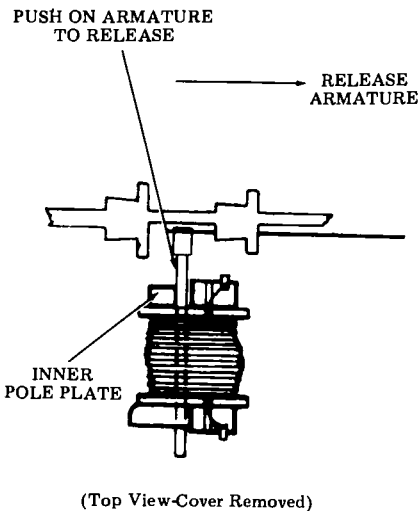
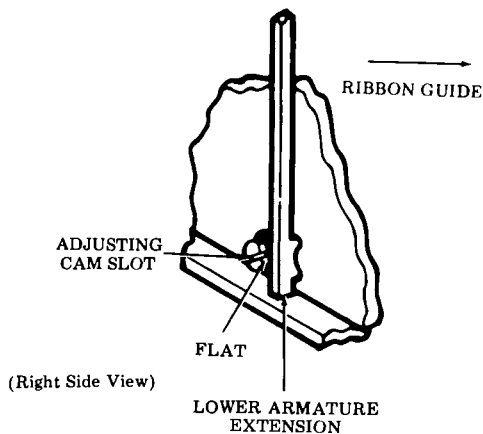

Requirement

With a good ribbon installed and the print head positioned and locked toward the platen, no wires shall stick through the ribbon (will not retract) and no dots shall be missing or noticeably lighter than other dots on printed copy.

To Adjust

Note: This adjustment applies to all 9 levels.  
(Power must be off for this adjustment)

Remove the ribbon and print head cover. Release the print head and position away from the platen. With the lower armature extension on the high part of the cam (adjusting cam slot horizontal and the flat facing toward the ribbon guide) and the armature released from the inner pole plate, rotate the adjusting cam slowly clockwise until the armature is magnetically pulled up. Continue rotating cam clockwise for 3 more clicks.

C. ADJUSTMENTS AND SPRING TENSIONS (Contd)

4. SPRING TENSIONS (Spring identification and location on Page 2-13.)

① 430028 Lead Screw Spring

On left side of lead screw, push to start to compress spring — 9 to 11 pounds.

② 430030 or 430366 Carriage Nut Spring

Place carriage on left side of unit. Hold lead screw pulley. Insert spring scale through top hole of left bearing housing. Push carriage with  $46 \pm 8$  ounces to compress nut spring.

②a 430366 Bias Spring

The free length of the bias spring (not assembled on the lead screw nuts) should be between 1.55 inch and 1.65 inch.

③ 430242 Ribbon Tension Spring

4-1/2 to 6-1/2 ounces to pull spring to installed length with ribbon installed.

④ 101386 Paper Finger Springs (Left and Right) (2)

2 to 4 ounces to start to lift paper fingers at front edge of fingers (with center paper guide installed).

⑤ 430021 SP Belt Tension Arm Spring

18 to 22 ounces to pull spring to installed length.

⑥ Bell Plunger (Striker) Spring (Old Bell)

1/2 to 1 ounce to seat plunger (430118).

⑥a 430411 Bell Plunger Spring (New Bell)

1 to 10 grams for striker (430411) to contact gong.

⑦ Link Spring (Part of 430216)

3/4 to 1-1/4 ounces at roll pin to hold spring in lowest position with locking handle in the most forward position.

⑧ 82463 Paper Tray Springs (Left and Right) (2)

On friction feed sets with plastic paper trays, move the printhead away from the platen. With a spring scale hooked over the center of the top edge of the tray, and pulling at right angles to the main surface of the tray, it should require 1 to 1-1/2 ounce to start the tray moving forward.

⑨ 430021 Line Feed Belt Tension Arm Spring

10 to 14 ounces to pull spring to installed length.

⑩ 82727 Pressure Roller Bail Spring (Friction Feed Only)

With the paper release lever in the rear position and pulling the pressure roller bail at the spring mounting hole at a right angle to the bail arm, it should take 46 to 56 ounces to start the roller bail moving.

SPRING IDENTIFICATION

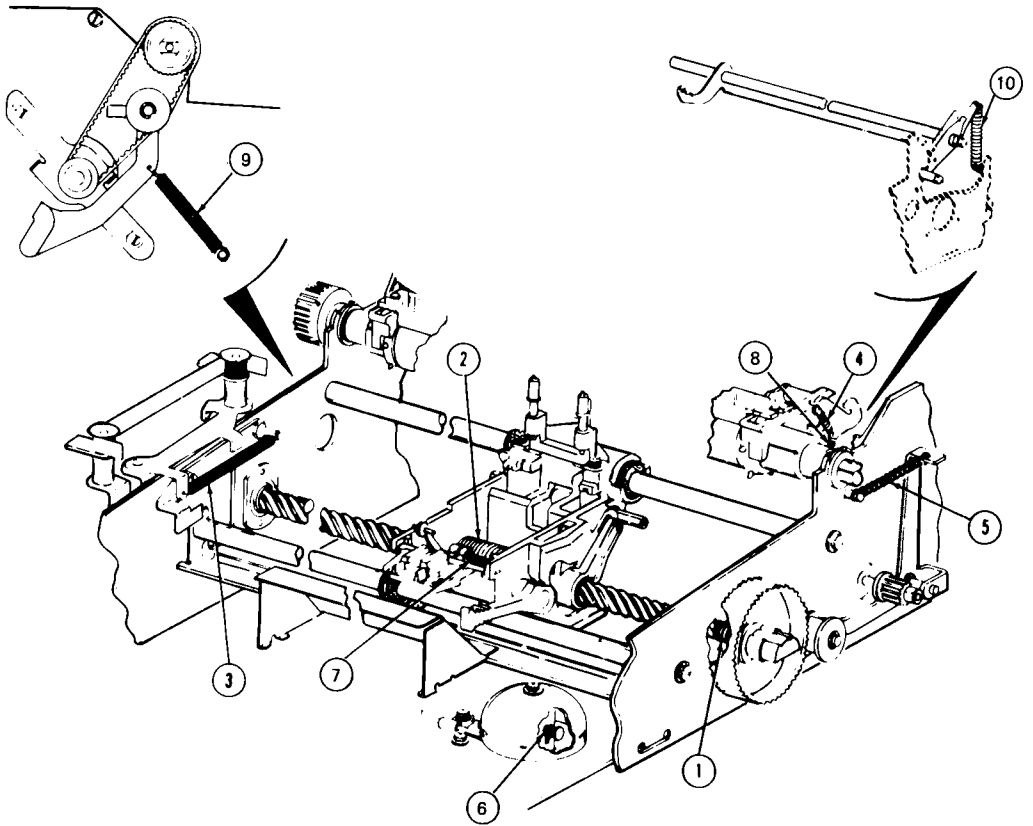



## D. LUBRICATION

<u>CONTENTS</u>	<u>PAGE</u>
1. GENERAL .....	2-14
2. LUBRICATION PROCEDURES . . . .	2-14
3. LUBRICATION POINTS .....	1-16

1. GENERAL

1.01 This part provides lubrication procedures for the Pedestal Based or Tabletop 42 Printer.

1.02 Lubricate the printer at intervals indicated under H. ROUTINE MAINTENANCE, Page 1-111.

1.03 The printer can be lubricated by opening the cabinet cover.

2. LUBRICATION PROCEDURES

2.01 Apply lubricant to points as indicated.

(a) On small parts, a minimum amount of lubricant should be applied so that the lubricant remains on the parts and does not run off.

(b) Excessive lubricant should be removed with a dry, lint-free cloth.

(c) The following areas must be kept dry, free of all lubricant: All electrical components, including terminals. All parts normally touched by the operator, including exposed surfaces in ribbon, paper handling areas, and all large flat areas.

2.02 The following symbols indicate the quantity of lubricant to be used in a specified area: Symbols O1, O2, O3, etc, refer to 1, 2, 3, etc, drops of oil.

2.03 The following list of symbols applies to the lubrication instructions and the type of lubricant to be used:

- O Oil 88970(1qt), 88971(1gal).
- G-A Apply thin film of 108805(3/4oz) or 454641(14oz) grease.
- G-B Apply thin film of Syn-Tech grease (use 430836 tube with grease and 430838 brush).
- G-C Fill with Poly Oil grease (use 430837 injector with grease).
- S Saturate felt oilers, washers, and wicks with oil.
- D Keep dry, no lubricant permitted.

2.04 Lubrication checklist: (See Pages 2-16 and 2-17).

Lead Screw — Film of grease over the entire threaded portion of lead screw.

Carriage Wicks — Saturate with oil (4 places).

Carriage Oiler — Saturate with oil.

Ribbon Guide Rollers — Two drops of oil (2 places).

Ribbon Rollers — Two drops of oil (2 places).

Ribbon Tension Arm Pivot and Spring — Two drops of oil each (4 places).

Spacing Tension Arm Pivot, Roller and Spring — Two drops of oil each (4 places).

Platen Bearing — Five drops of oil each side (2 places).

Finger Pivots — Two drops of oil each side (2 places).

Lead Screw Pulley Clip — Grease between clip and lead screw shaft.

Pressure Roller Bail Spring — Two drops of oil each end (2 places).

Platen Tray Shaft — Two drops of oil each end at the side plates (2 places).

Pressure Roller Bail — Two drops of oil each end at pivot points on each side of bail (2 places).

All Spring Eyeloops at the Anchor Points — One drop of oil.

Line Feed Floating Motor Mounting Points — One drop of oil at each mounting point.

Carriage and Nut Engaging Surfaces:

- (a) Two Nut Drive Arms — Grease four bearing surfaces.
- (b) Nut Keying Arm — Lubricate by packing carriage engaging slot with grease.

Print Head:

- (a) Active Armatures and Outer Pole Plate -- Grease at the upper pivot area as well as the lower locator area (9 places).
- (b) Print Wire Well Area - Completely fill with grease.

D. LUBRICATION (Contd)

3. LUBRICATION POINTS

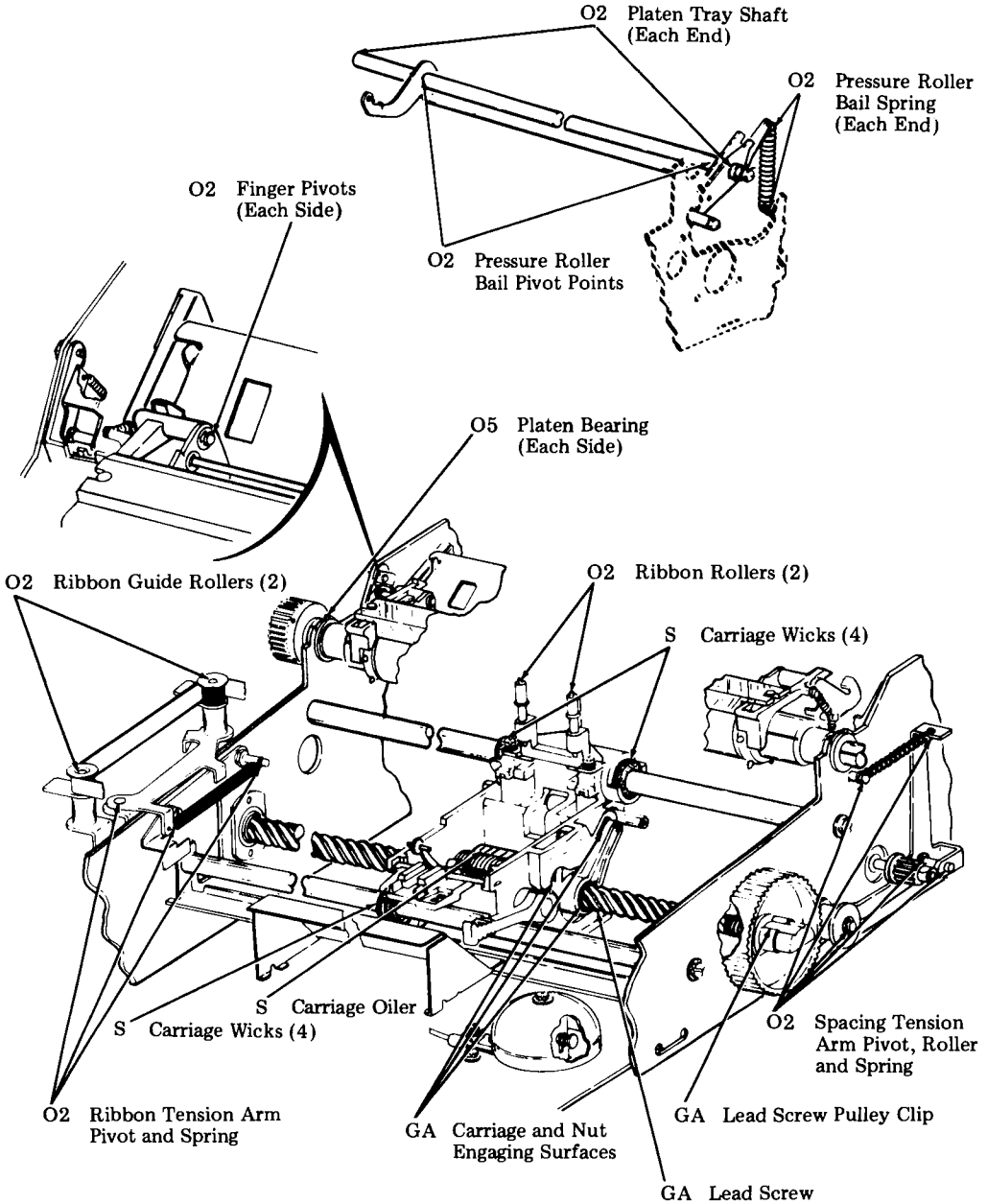

G-C Print Head Well Area

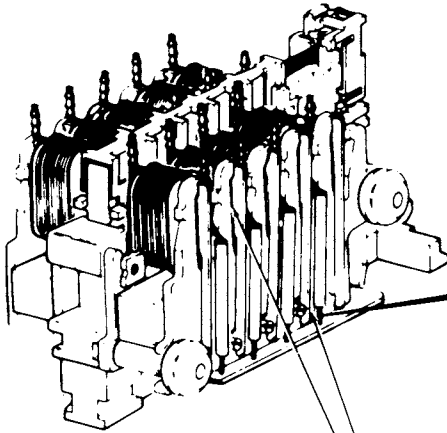
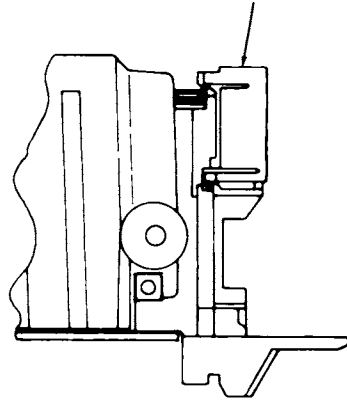

G-B Print Head Active Armatures and Outer Pole Plates

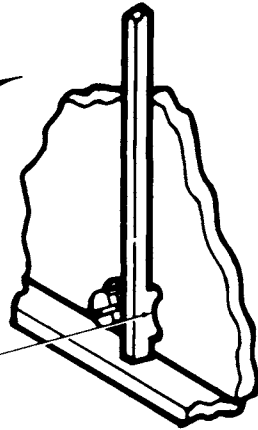

E. DISASSEMBLY/REASSEMBLY

<u>CONTENTS</u>	<u>PAGE</u>	
1. GENERAL . . . . .	2-18	1.04 When removing a subassembly or part from the printer, follow the removal procedure and note the sequence of removal to enable proper reassembly. For reassembly, reverse the procedure except where different instructions are given. Perform any adjustments indicated see Page 2-5.
2. TOOLS REQUIRED . . . . .	2-19	1.05 Disassembly of printer parts except the print head will require the removal of the set housing and rear frame. Refer to Teletype Disassembly/Reassembly, Page 1-92 for set housing and rear frame removal and replacement procedures.
3. DISASSEMBLY/REASSEMBLY . . . . .	2-20	1.06 Disassembly of the printer motors will require the removal of the logic card.
PRINT HEAD WITH COVER . . . . .	2-20	1.07 Disassembly of the printer lead screw, carriage with post assembly, lead screw nut, and collar with link will require the removal of the keyboard.
SPACING MOTOR BELT . . . . .	2-23	1.08 After replacing printer parts, refer to the lubrication procedures Page 2-16 and lubricate any parts requiring lubrication.
SIGNAL BELL . . . . .	2-23	1.09 Some parts that are not listed in the parts sections are shown as necessary to the disassembly procedures such as screws and ring retainers, etc. These parts are common to other Teletype Corporation product lines and if needed may already be available in field repair kits or can be ordered.
SPACING MOTOR WITH CABLE AND ENCODER . . . . .	2-25	1.10 When ordering replaceable components, unless otherwise specified, prefix each part number with the letters "TP" (ie, TP410324).
LINE FEED MOTOR . . . . .	2-27	1.11 Reference in the procedures to left and right, up or down, and top or bottom, etc, refer to the printer in its normal operating position.
PLATEN . . . . .	2-29	
LEAD SCREW . . . . .	2-31	
CARRIAGE WITH POST ASSEMBLY . . . . .	2-32	
LEAD SCREW NUT . . . . .	2-32	
COLLAR WITH LINK . . . . .	2-33	
PAPER TRAY . . . . .	2-34	
PAPER GUIDES . . . . .	2-35	
1. <u>GENERAL</u>		
1.01 This part covers disassembly/reassembly procedures for the Pedestal Based or Table-top 42 Printer.		
1.02 The printer is not considered a field replaceable item. Any trouble can be corrected by adjustments or by replacement with maintenance spares.		
1.03 Procedures are provided to remove individual assemblies and parts and are intended to directly access any assembly or part, insofar as possible, without total disassembly of the unit.		

2. TOOLS REQUIRED

2.01 The following tools may be required when performing the printer disassembly/reassembly procedures. Most of these items should normally be present in standard maintenance tool kits.

<u>Part No.</u>	<u>Description</u>	<u>Part No.</u>	<u>Description</u>
75765	Hook, Pull Spring	108285	Pliers, Long-Nose
95368	Screwdriver, 1/8 Inch, 2 Inch Blade	110271	Wrench, Hex Key
100704	Screwdriver w/Clip, 10 Inch Blade	124682	Wrench, Hex Key
100982	Screwdriver w/Clip, 1/4 Inch 6 Inch Blade	125752	Wrench, 3/16 Inch Socket
		129534	Wrench, Open End, 3/16 Inch and 1/4 Inch
		348097	Nut Driver 1/4 Inch
		348098	Nut Driver 5/16 Inch
		142554	Hook, Pull Spring
		142555	Hook, Push Spring
		151392	Tweezers
		152835	Wrench, Open End, 5/16 Inch and 3/8 Inch
		407326	Extractor, I.C.

E. DISASSEMBLY/REASSEMBLY (Contd)

3. DISASSEMBLY/REASSEMBLY

PRINT HEAD WITH COVER

3.01 To remove the print head with cover:

*Caution:* When handling loose print heads, care must be taken to prevent print head cable connector pins from being bent.

*Note:* Print head removal and replacement is also shown in Disassembly/Reassembly, Page 1-92.

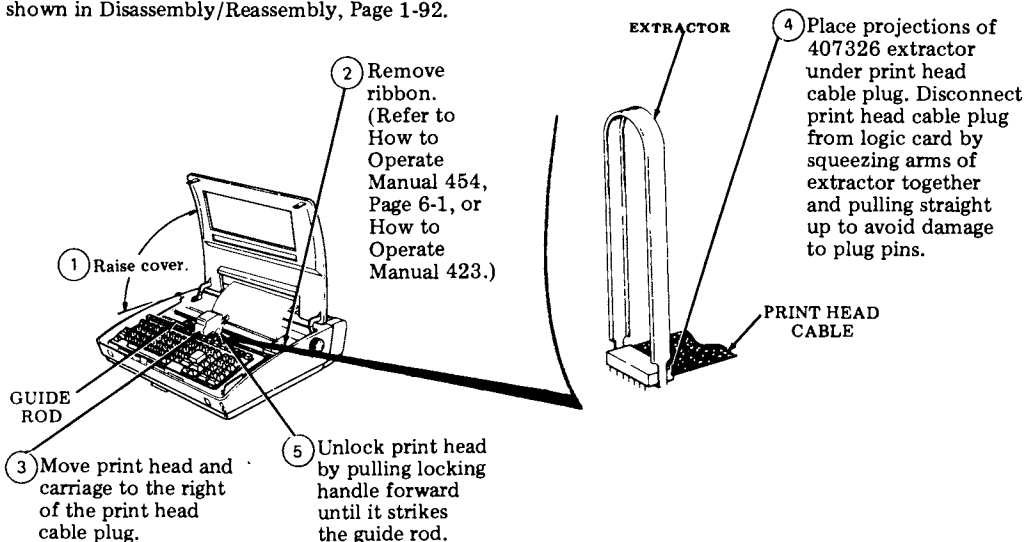

8 Grasp print head and pull forward. Lift front of print head to disengage locking channels.

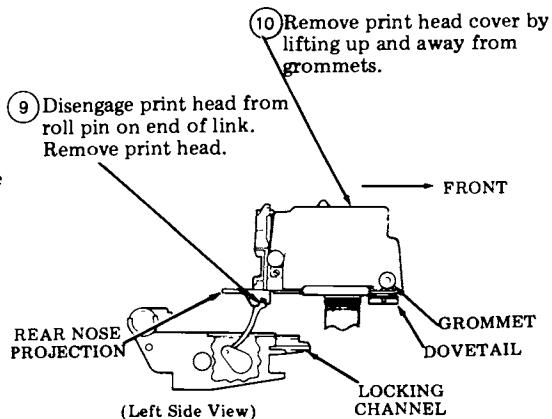
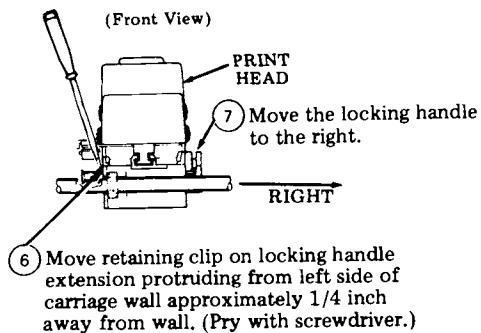

3.02 To replace the print head with cover:

*Caution: When handling loose print heads, care must be taken to prevent print head cable connector pins from being bent.*

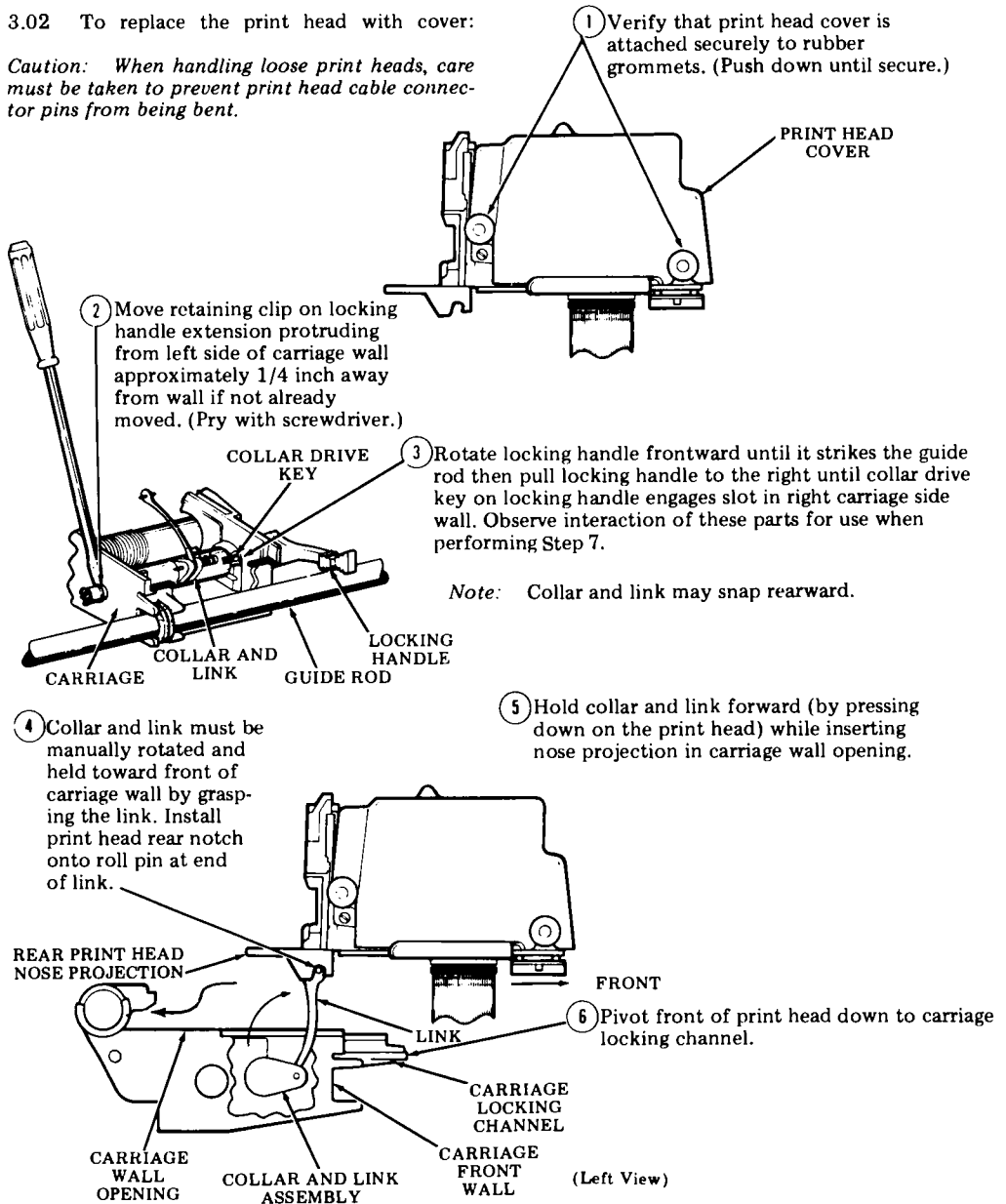

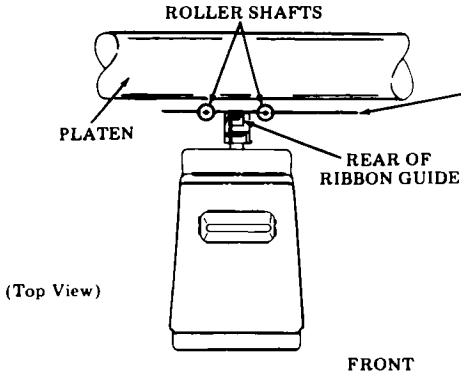

E. DISASSEMBLY/REASSEMBLY (Contd)3. DISASSEMBLY/REASSEMBLY (Contd)PRINT HEAD WITH COVER (Contd)

- 7 Slowly push print head rearward and further into the carriage locking channel until the rear of the ribbon guide is even with center of roller shafts. Apply continuous leftward pressure to locking handle at its pivot shaft, while slowly pulling print head forward until collar drive key on handle engages (snaps) into slot in collar.

*Note:* Parts referred to were visible in Step 3.

- 9 Position and hold print head and carriage assembly to right side of printer and use a 5/16 inch socket wrench to push clip against carriage wall.

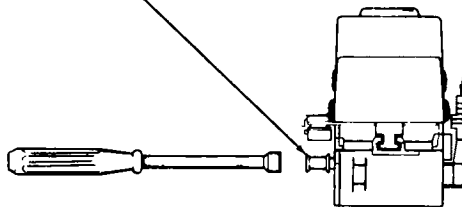

- 8 Move the handle all the way to the rear, locking the print head in close proximity to the platen by the additional force necessary to detent the handle. If handle does not move to rear, the drive key did not properly engage the collar slot (step 7).

*Note:* Check to make sure there is some clearance between print head and platen before detenting handle. Check PRINT HEAD TO PLATEN adjustment.

- 10 Check that no connector pins are bent and carefully connect the print head cable plug to the logic card. Make sure cable does not touch left side frame when the carriage moves fully left.

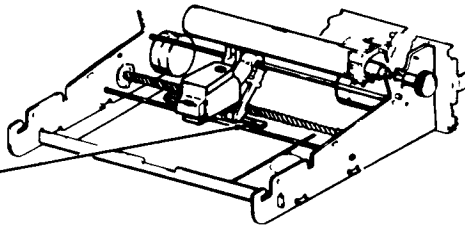

- 11 Install ribbon. (Refer to How to Operate Manual 454, Page 6-1 or How to Operate Manual 423.)

SPACING MOTOR BELT

3.03 To remove the spacing motor belt:

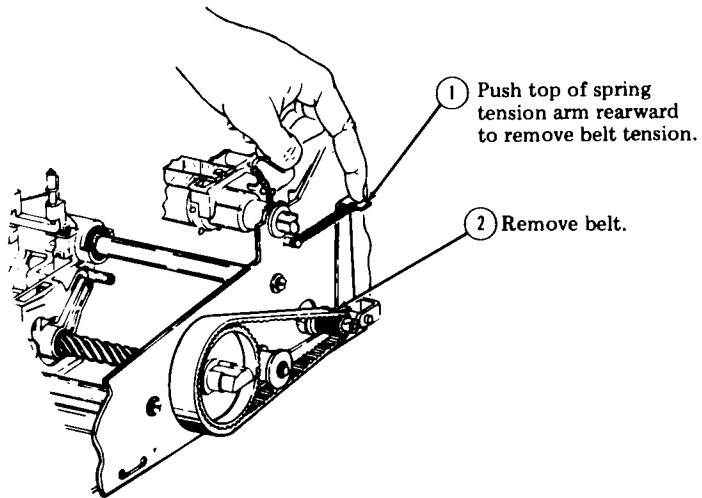

SIGNAL BELL

3.04 To remove and disassemble the signal bell assembly:

(a) Early Design Arrangement

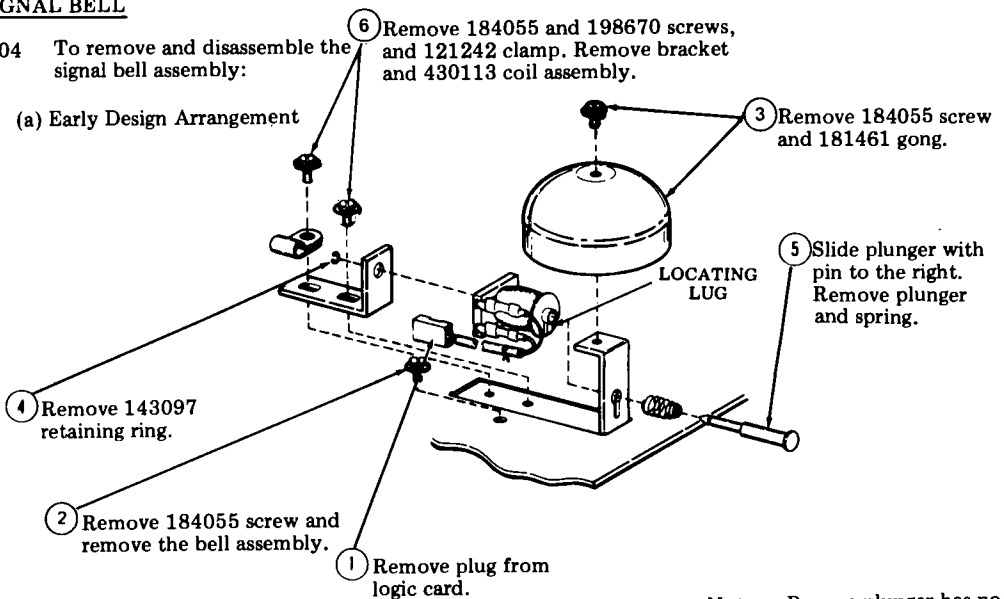

*Note:* Be sure plunger has no interference when reassembled.

E. DISASSEMBLY/REASSEMBLY (Contd)

3. DISASSEMBLY/REASSEMBLY (Contd)

SIGNAL BELL (Contd)

(b) Late Design Arrangement

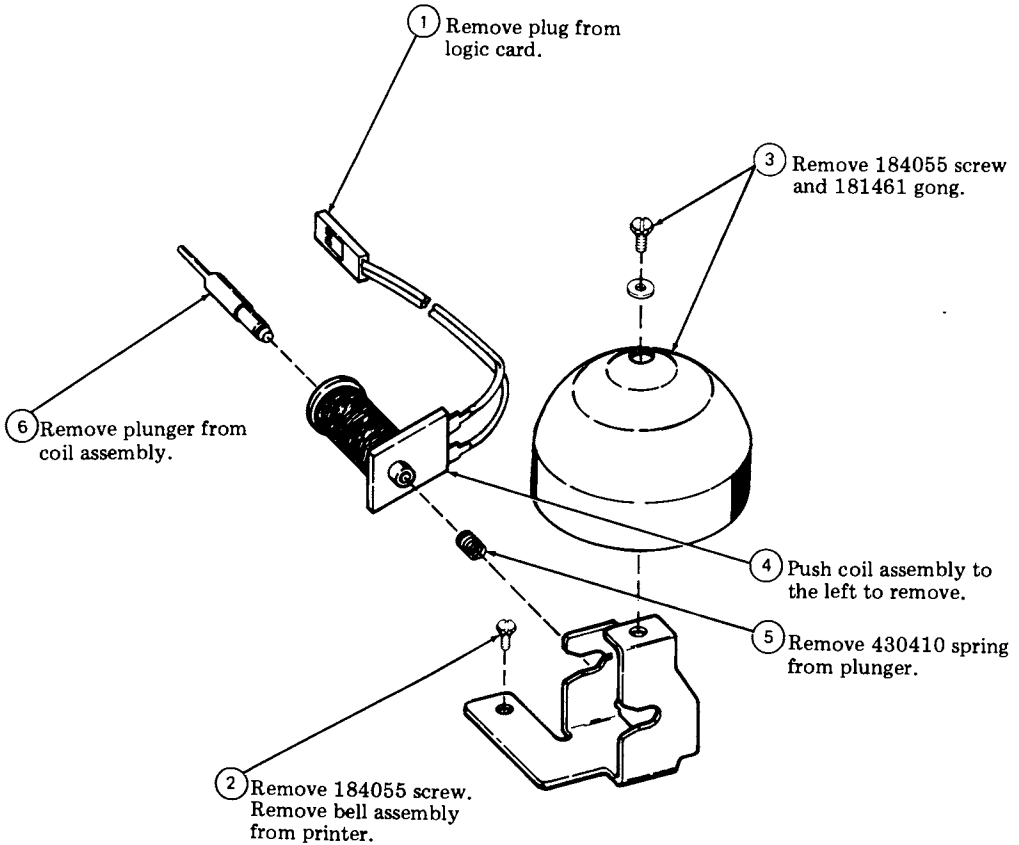

SPACING MOTOR WITH CABLE AND ENCODER

3.05 To remove the spacing motor:

- ① Remove the logic card (if present).  
See Page 1-99.

(Right Side View)

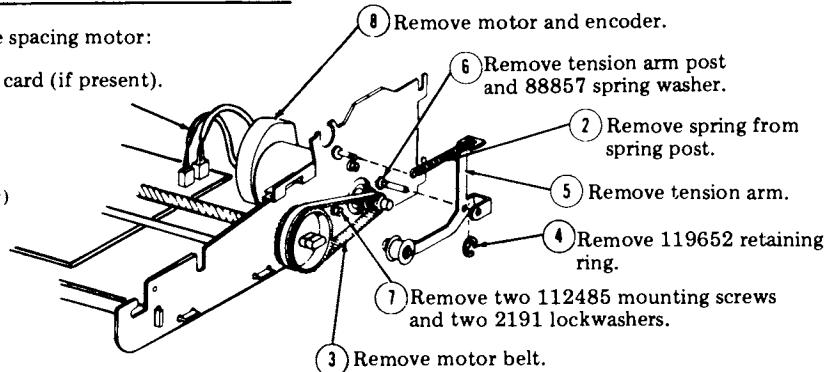

(a) The 430047 motor with cable and encoder.

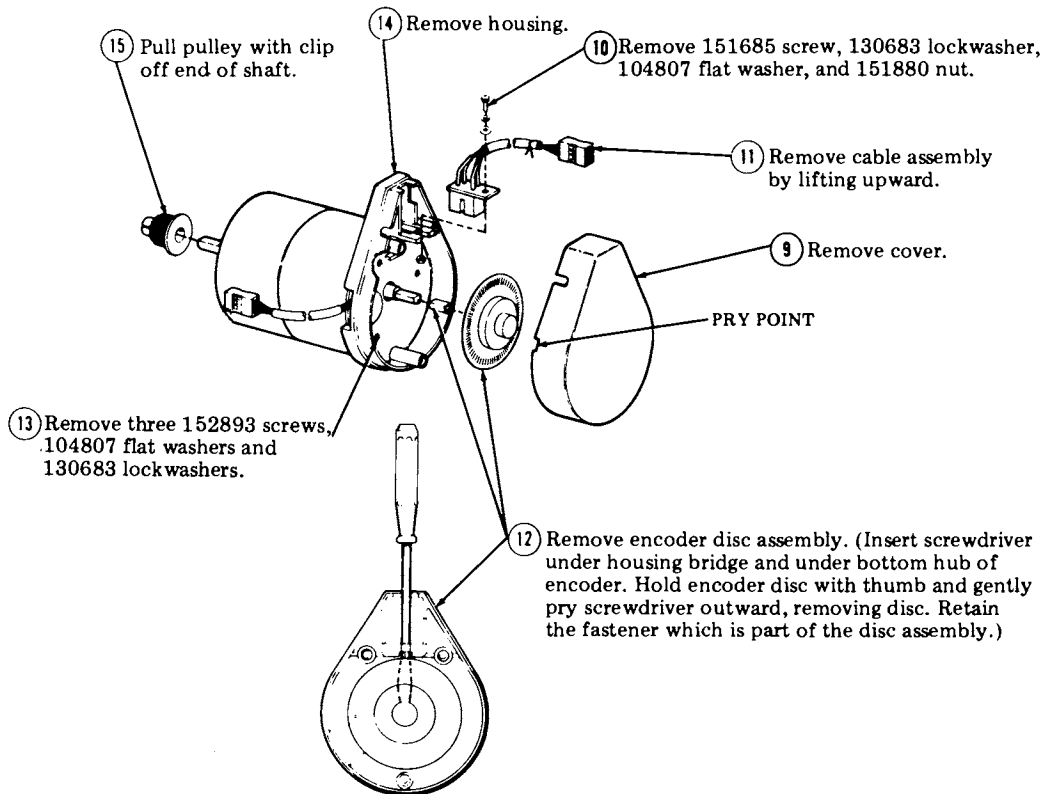

**Warning:** Do not pull on metal disc edges as this will deform encoder disc causing it to rub against the encoder.

**Note:** In reassembly, make sure disc does not rub on encoder assembly.

E. DISASSEMBLY/REASSEMBLY (Contd)

3. DISASSEMBLY/REASSEMBLY (Contd)

SPACING MOTOR WITH CABLE AND ENCODER (Contd)

(b) 430441 Motor with cable and encoder.

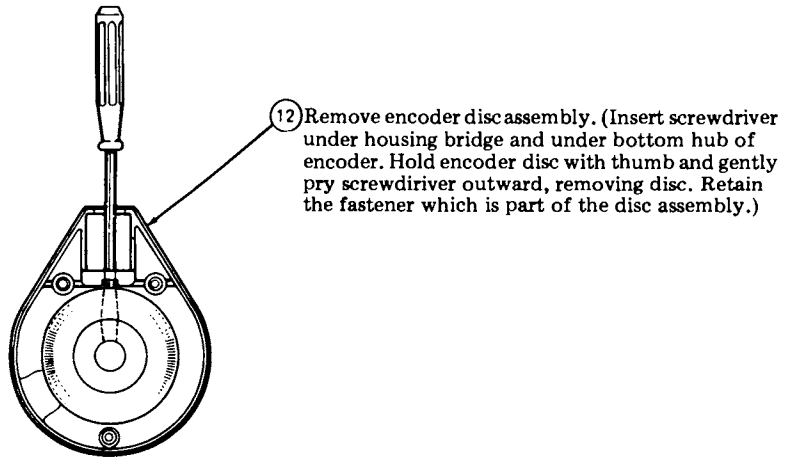
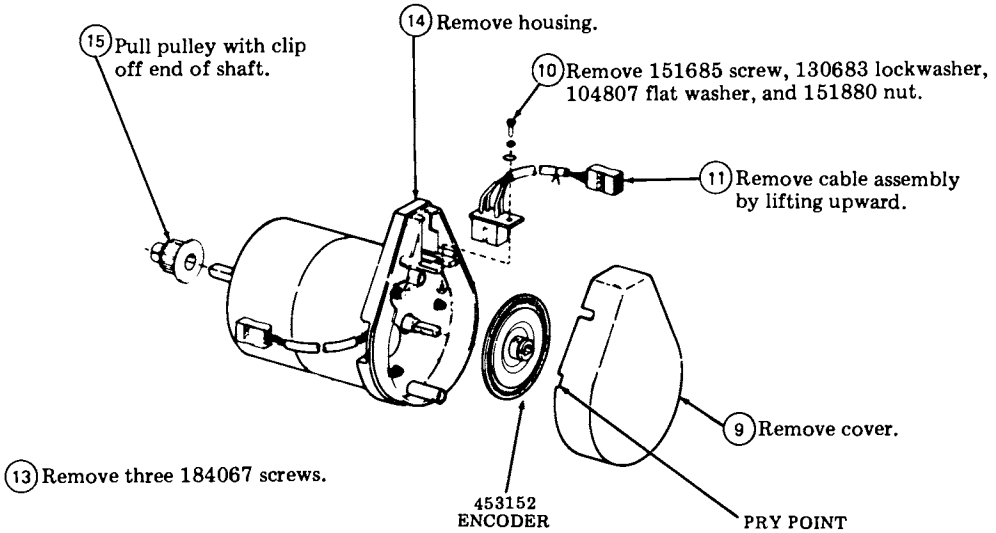

*Note:* In reassembly, make sure disc does not rub on encoder assembly.

**LINE FEED MOTOR**

3.06 To remove the line feed motor:

(a) Without tension arm

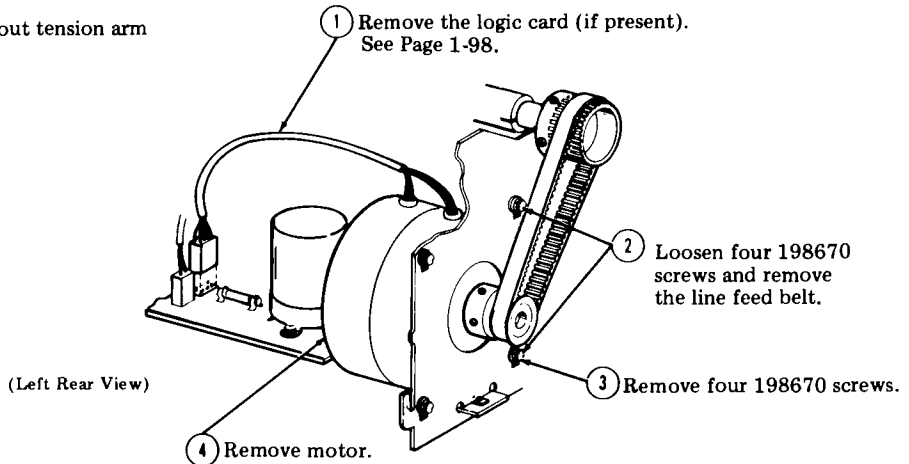

Note: In reassembly, perform LINE FEED BELT TENSION adjustment

(b) With tension arm

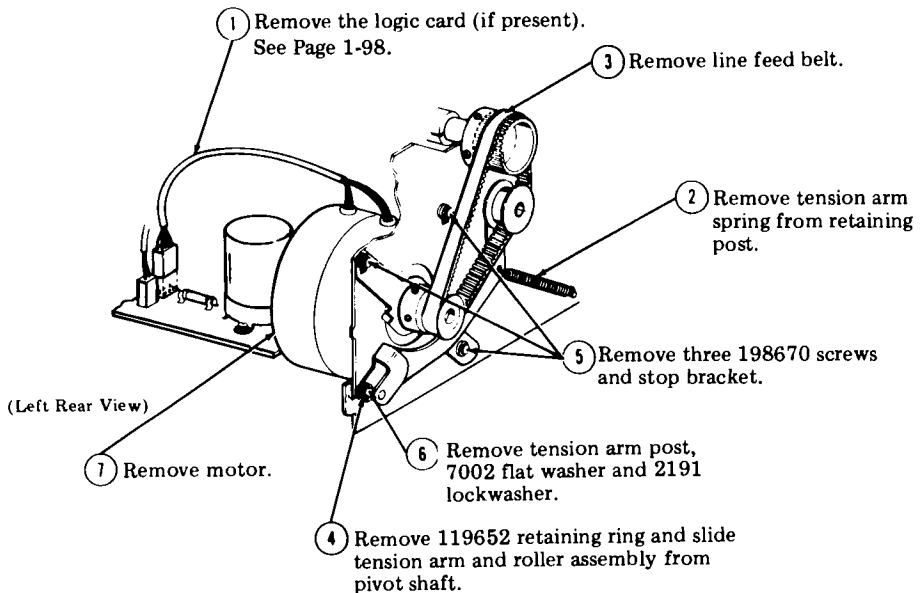

Note: In reassembly, perform STOP BRACKET adjustment.

E. DISASSEMBLY/REASSEMBLY (Contd)

3. DISASSEMBLY/REASSEMBLY, LINE FEED MOTOR (Contd)

3.06 To remove the line feed motor: (Contd)

(c) With floating motor

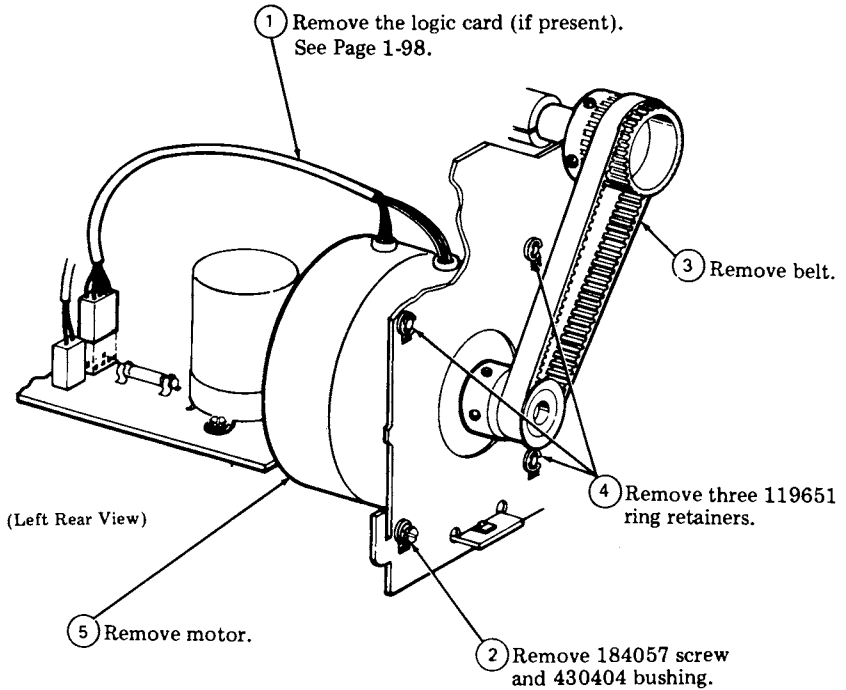

PLATEN

3.07 To remove the platen:

(a) Motor without tension arm or floating motor

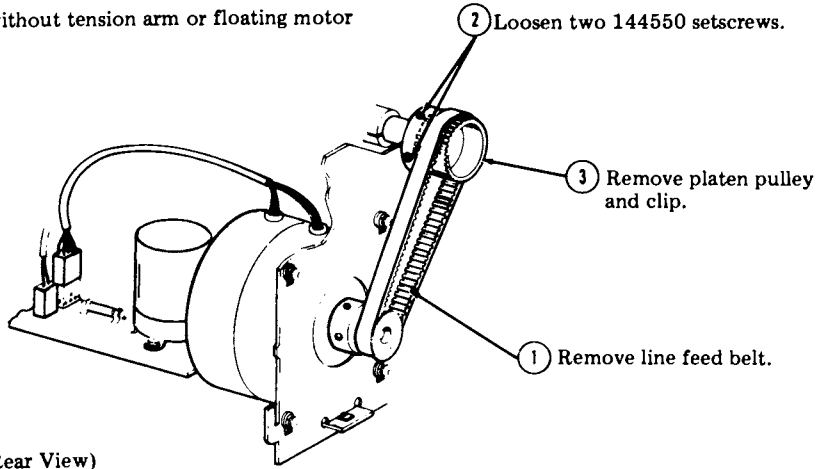

Note: In reassembly, position the setscrews away from the slot in the platen clip.

(b) Motor with tension arm

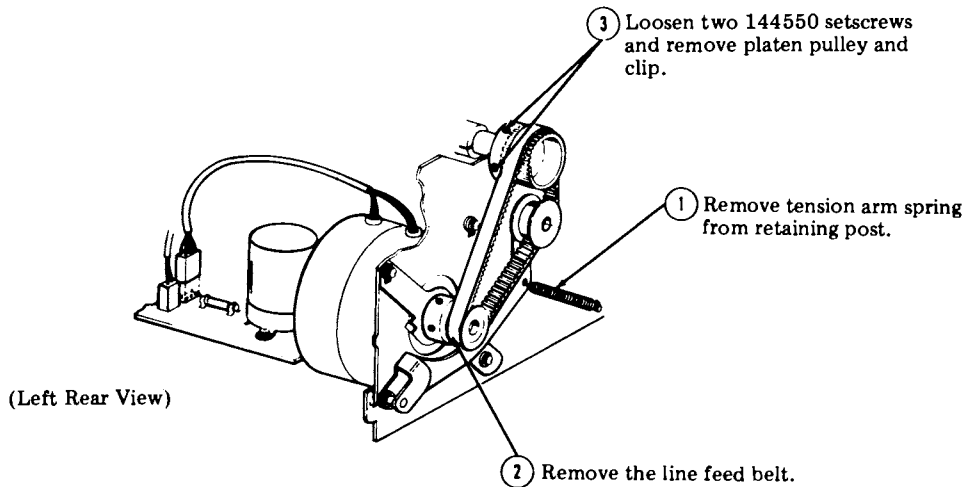



E. DISASSEMBLY/REASSEMBLY (Contd)

3. DISASSEMBLY/REASSEMBLY, PLATEN (Contd)

(c) Early Design Platen

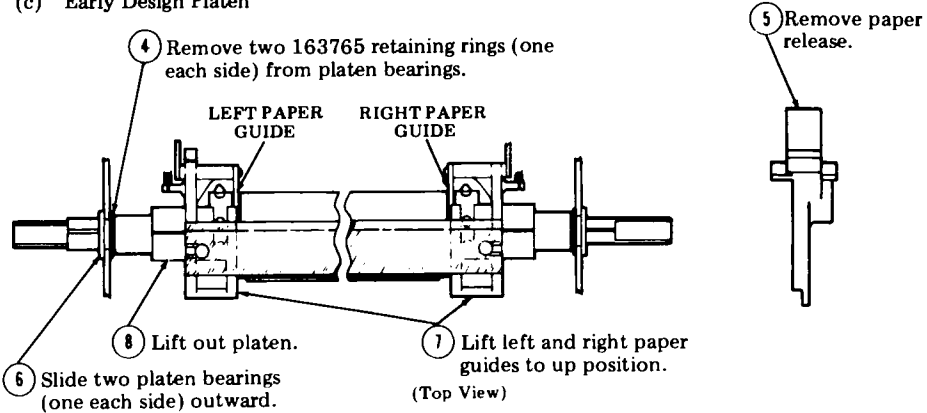

(d) Late Design Platen

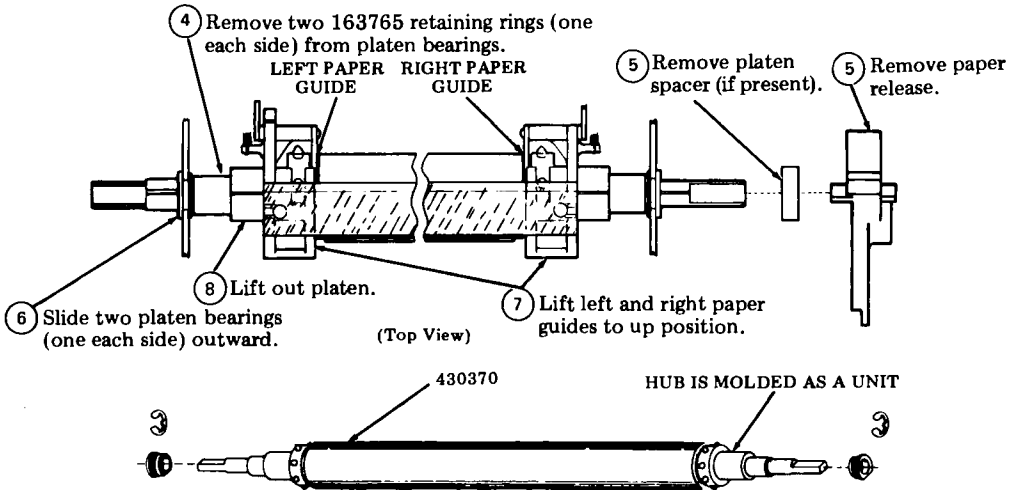

PLATEN ASSEMBLY

Perform the PLATEN ENDPLAY adjustments after assembly.

**LEAD SCREW**

3.08 To remove the lead screw :

① Remove operator console if present.

ONE OR TWO PIECE  
LEFT BEARING

④ Push in right bearing housing to clear right frame. Rotate 90 degrees and spring will force bearing and housing away from side frame. Remove housing with bearing, inner bearing or shim, and spring.

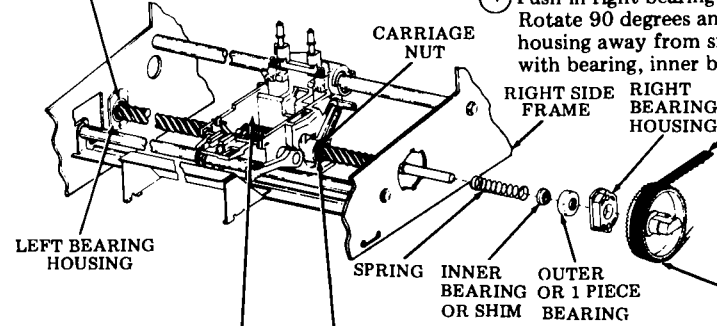

② Remove spacing belt.

③ Remove lead screw pulley and clip by pulling to the right.

⑤ Unscrew lead screw from carriage nut and remove through hole in right side frame. Retain left inner bearing, is used, which will be free when lead screw is removed.

(Right Side View)

E. DISASSEMBLY/REASSEMBLY (Contd)

3. DISASSEMBLY/REASSEMBLY (Contd)

CARRIAGE WITH POST ASSEMBLY

3.09 To remove the carriage with post assembly:

*Note:* The upper guide rod must be nickel plated. The lower guide rod may be nickel plated or black oxide.

- ① Remove keyboard, if present.  
See Page 1-92.
- ② Remove print head and lead screw  
(perform 3.01 and 3.08).
- ③ Move carriage to left margin.  
Remove carriage cable from  
logic card.
- ④ Remove screw and washer  
from each guide rod.

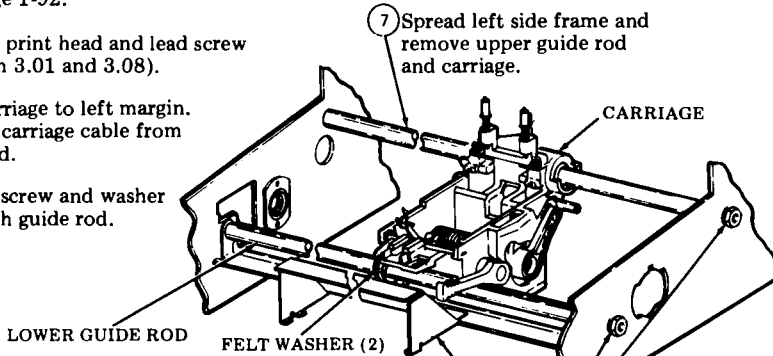

- ⑥ Spread clamp with cover and disengage from  
logic card (if present). Spread left side frame  
outward to disengage left end of lower guide  
rod, then pull toward the front to remove lower  
guide rod, two felt washers and clamp with  
cover.

- ⑤ Remove a 112626 nut and a 45815  
lockwasher from each guide rod.

LEAD SCREW NUT

3.10 To remove the lead screw nut:

- ① Remove keyboard, if present.  
See Page 1-92.
- ② Remove print head and lead screw  
(perform 3.01 and 3.08).
- ③ Tilt lead screw nut  
handle outward to  
clear retaining  
notch in carriage.  
Rotate counterclock-  
wise (CCW) until  
tabs on nut align  
with opening in  
carriage. Spring  
will force nut  
away from carriage.
- ④ Remove springs and nuts.

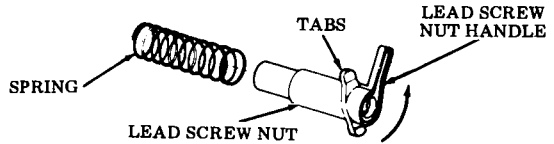

ROTATE  
CCW  
Early Design Nut Arrangement

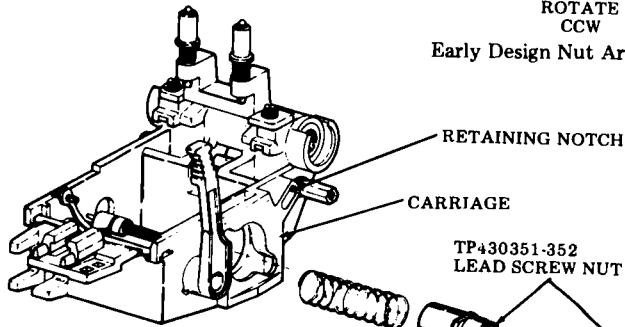

Late Design Nut Arrangement  
LEAD SCREW  
NUT HANDLE

*Note:* The 430351 and 430352 lead  
screw nuts are keyed and must be engaged  
when properly installed.

COLLAR WITH LINK

3.11 To remove the collar with link:

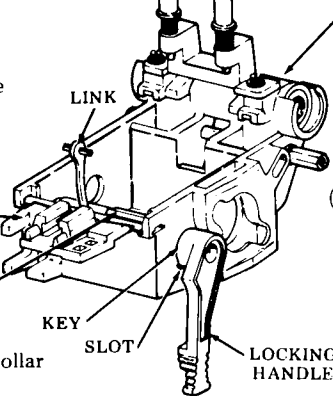
- ① Remove keyboard, if present.  
See Page 1-92.
- ② Remove print head and carriage  
(perform 3.01 and 3.09).
- ③ Remove compression ring.  

- ④ Push locking handle to the left and rotate locking handle and collar fully counterclockwise (forward). Pull the handle to the right while slowly rotating handle and collar clockwise (rearward) until key on handle aligns with slot in carriage. Locking handle will pop out.  

- ⑤ Remove collar with link.

E. DISASSEMBLY/REASSEMBLY (Contd)3. DISASSEMBLY/REASSEMBLY, PAPER TRAY (Contd)

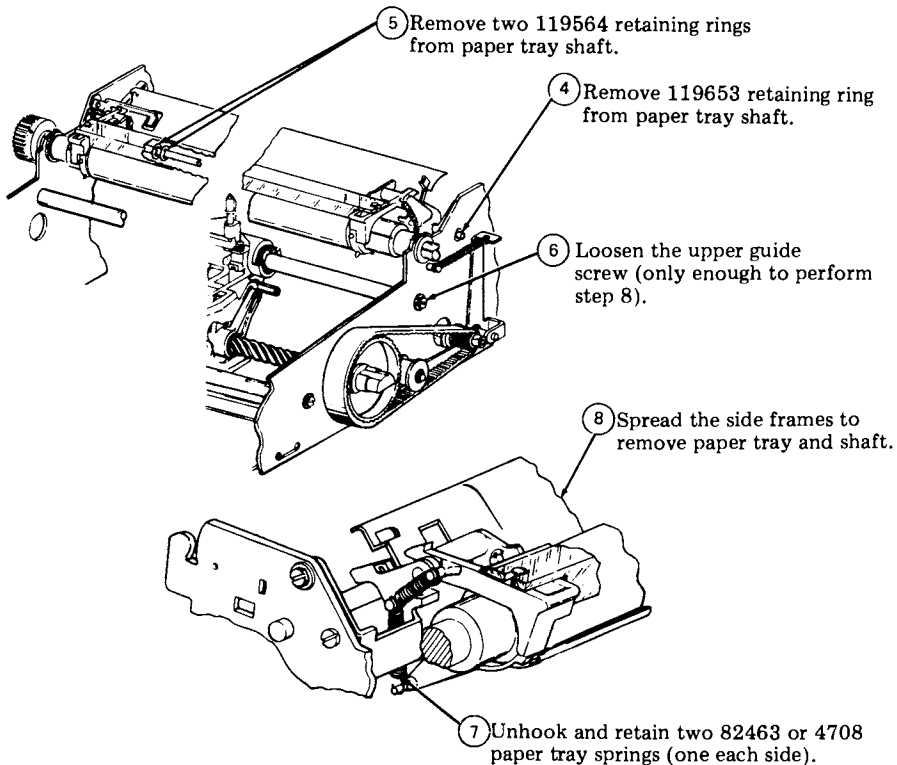
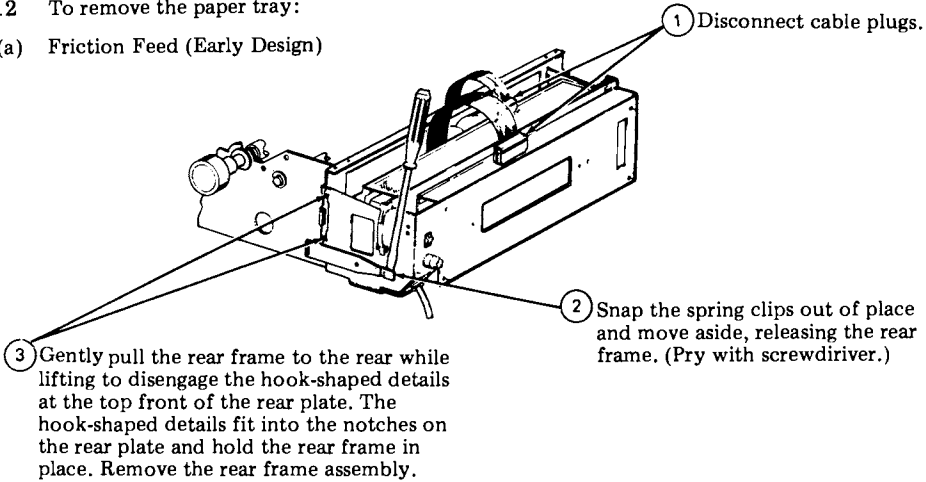
3.12 To remove the paper tray:

(a) Friction Feed (Early Design)



(b) Friction Feed (Late Design)

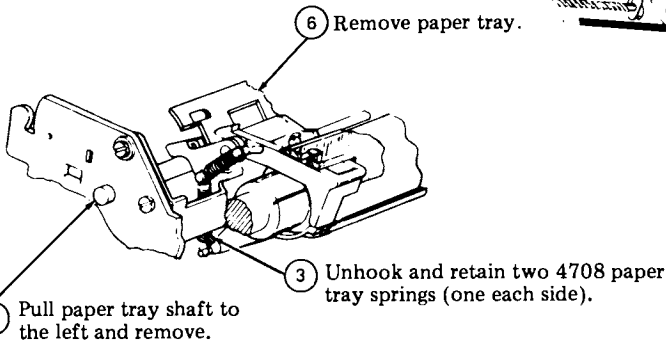
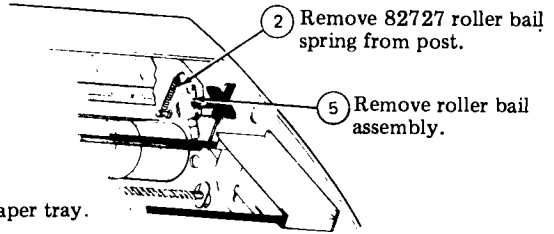

PAPER GUIDES

3.13 To remove the paper guide:

*Note 1:* Left and right guides are removed in a similar manner.

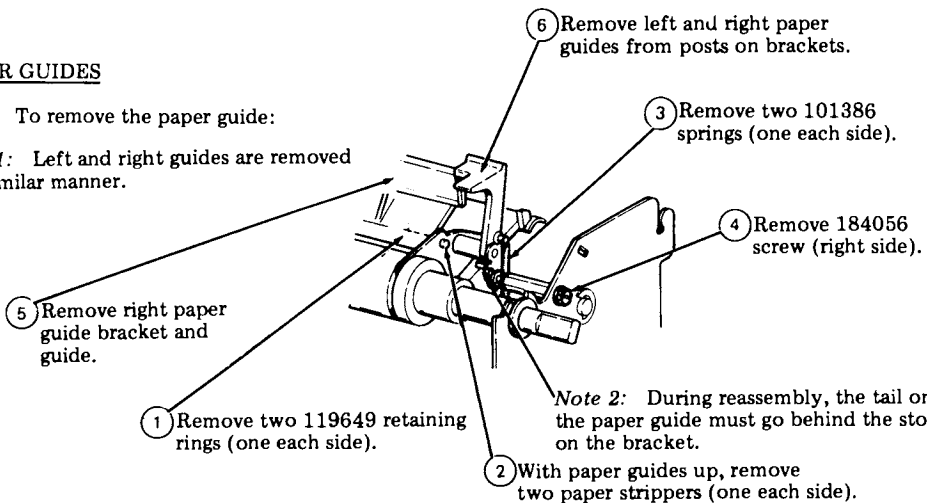

*Note 2:* During reassembly, the tail on the paper guide must go behind the stop on the bracket.

*Note 3:* In reassembly, RIGHT PAPER GUIDE adjustment must be made.

F. PARTS

<u>CONTENTS</u>	<u>PAGE</u>
1. GENERAL .....	2-36
2. PARTS .....	2-37
Platen and Carriage Assembly .....	2-37
Line Feed Motor and Bell Assembly .....	2-38
Spacing Motor, Drive and Lead Screw .....	2-39
Right Side Frame (Friction Feed) ...	2-40
Right Side Frame (Sprocket Feed) and Rear Frame .....	2-41
Paper Tray .....	2-42
Left Side Frame .....	2-43
3. NUMERICAL INDEX .....	2-44

1. GENERAL

1.01 Information on maintenance spare parts is provided in this part for the Pedestal Based or Tabletop 42 Printer.

1.02 Part numbers are listed in the index in numerical order and indicate the page on which the parts appear. Asterisked numbers, stocked as "List 1", indicate a maintenance spare stocking ratio of one spare for the first twenty stations and an additional spare for each additional 30 stations in a maintenance area. Part numbers without asterisks, stocked as "List 2", indicate that one spare should be available in each maintenance area.

1.03 When ordering replaceable components, unless otherwise specified, prefix each part number with the letters "TP" (ie, TP410324).

1.04 The troubleshooting and disassembly/reassembly information for these parts is provided on Pages 2-1 and 2-18 respectively.

2. PARTS

Platen and Carriage Assembly

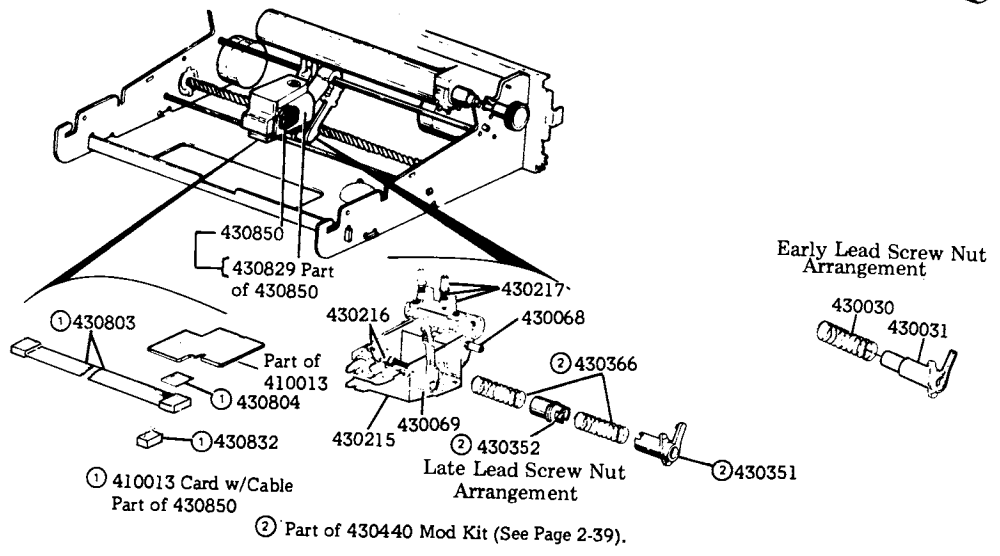
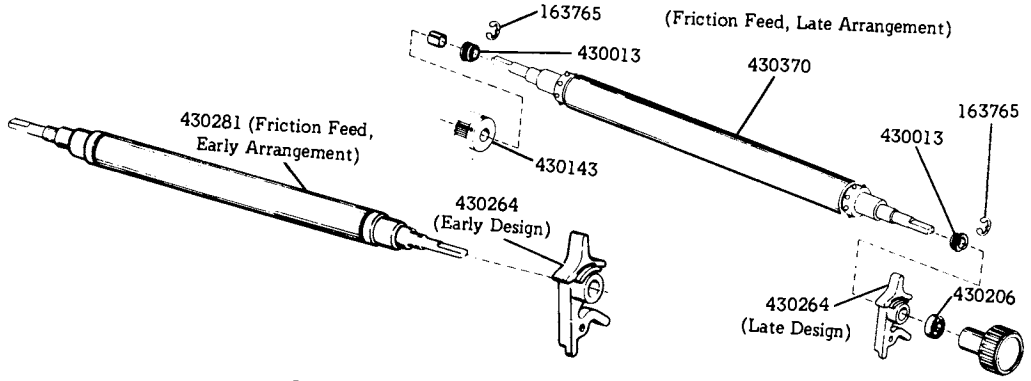



F. PARTS (Contd)

2. PARTS (Contd)

Line Feed Motor and Bell Assembly

(Friction Feed Early Design Drive)

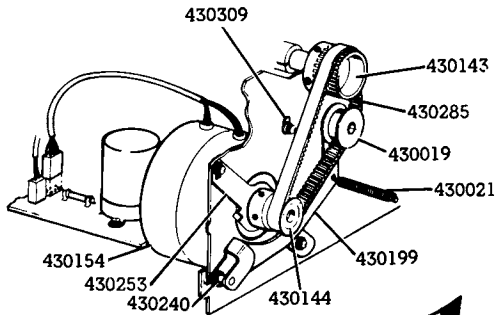

(Late Design Friction Feed)

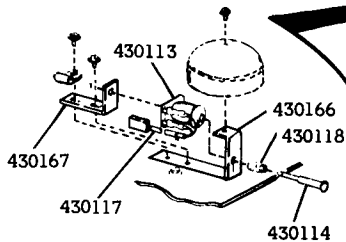
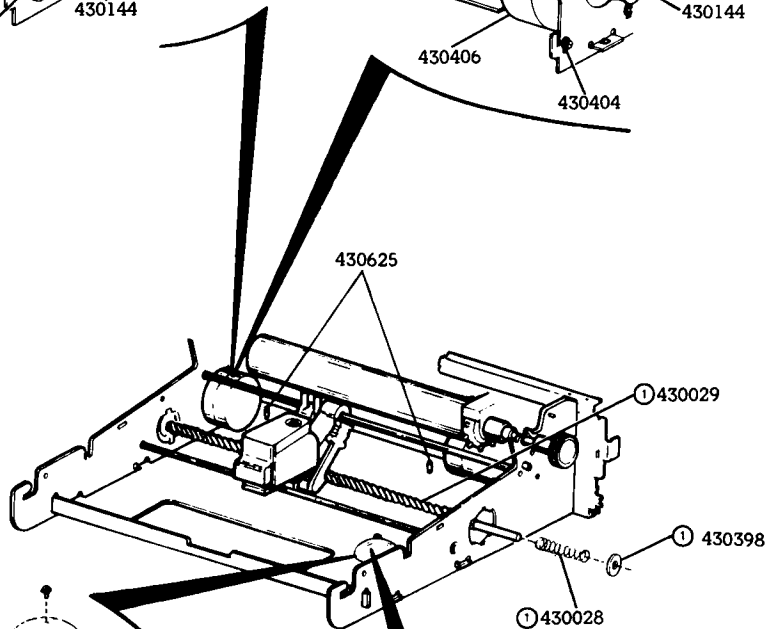
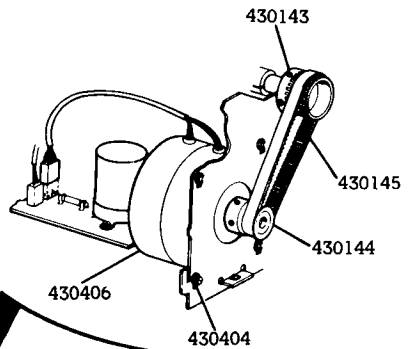

(Bell Assembly, Early Design)

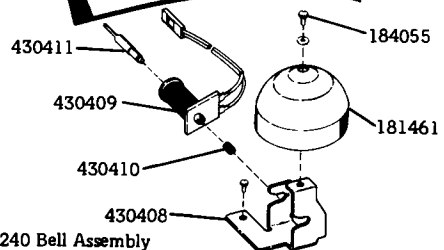

453240 Bell Assembly  
Late Design

⊙ Part of 430440 Mod Kit (See Pages 2-37 and 2-39).

Spacing Motor, Drive and Lead Screw

① 430047 Motor w/Cable and Encoder

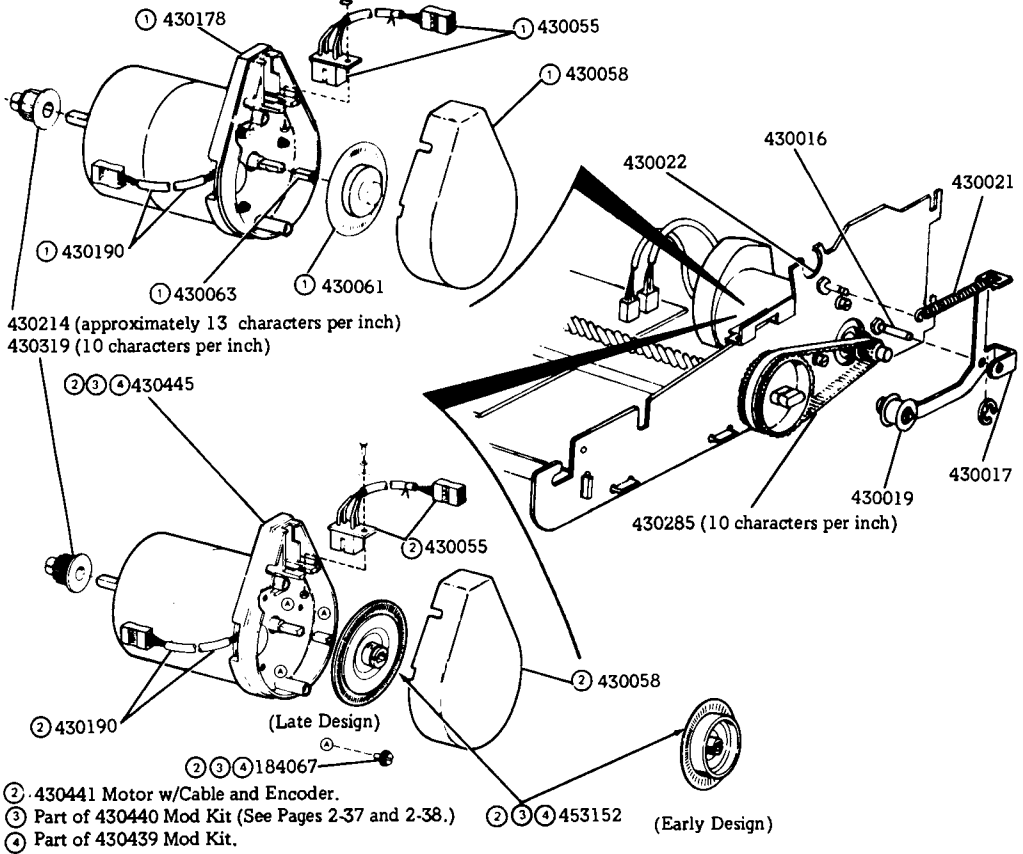

② 430441 Motor w/Cable and Encoder.

③ Part of 430440 Mod Kit (See Pages 2-37 and 2-38.)

④ Part of 430439 Mod Kit.

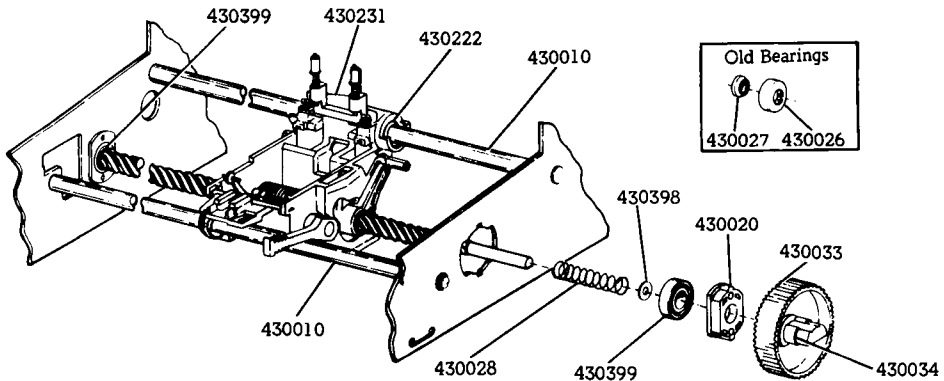

F. PARTS (Contd)

2. PARTS (Contd)

Right Side Frame (Friction Feed)

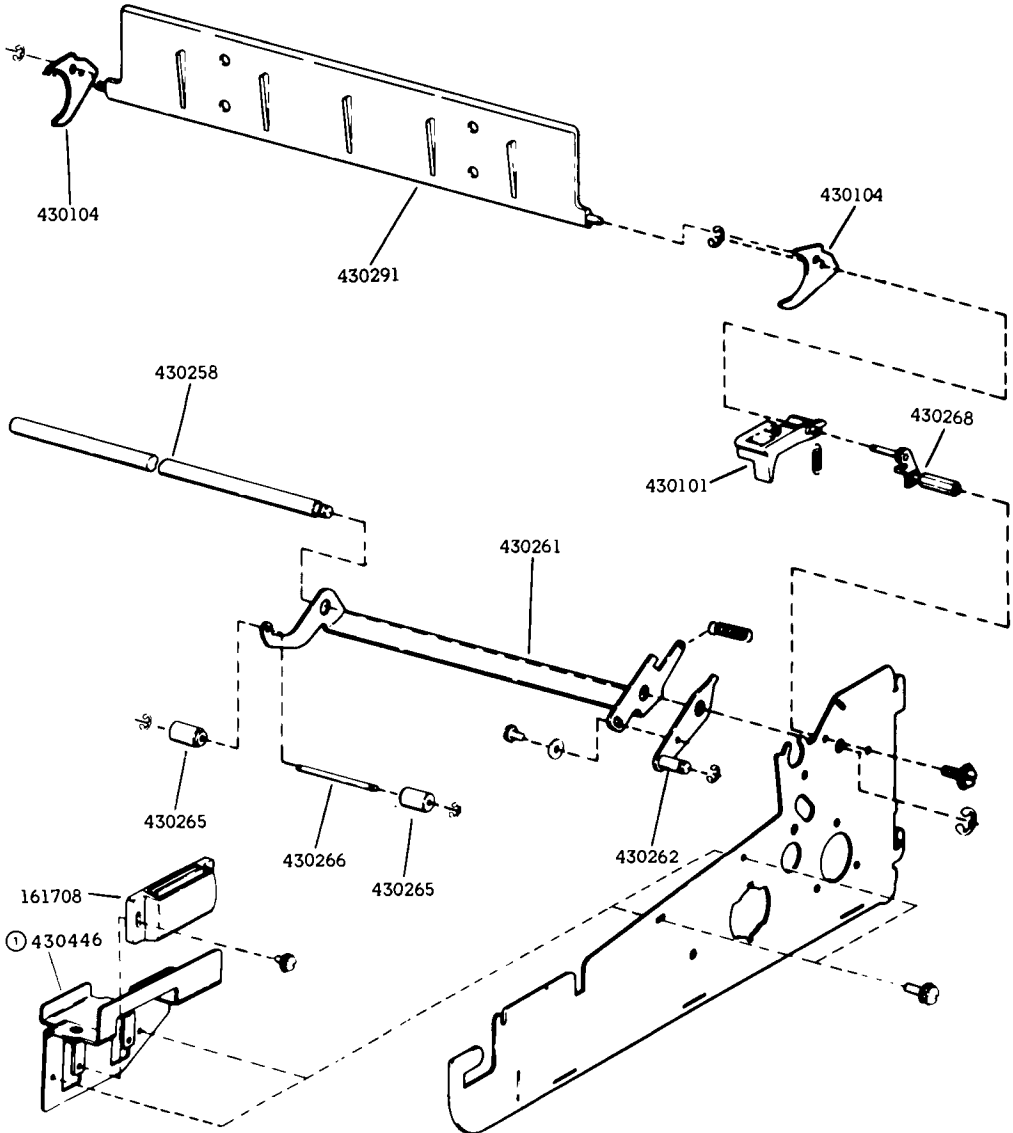

① 430446 replaces 430180

Right Side Frame and Rear Frame

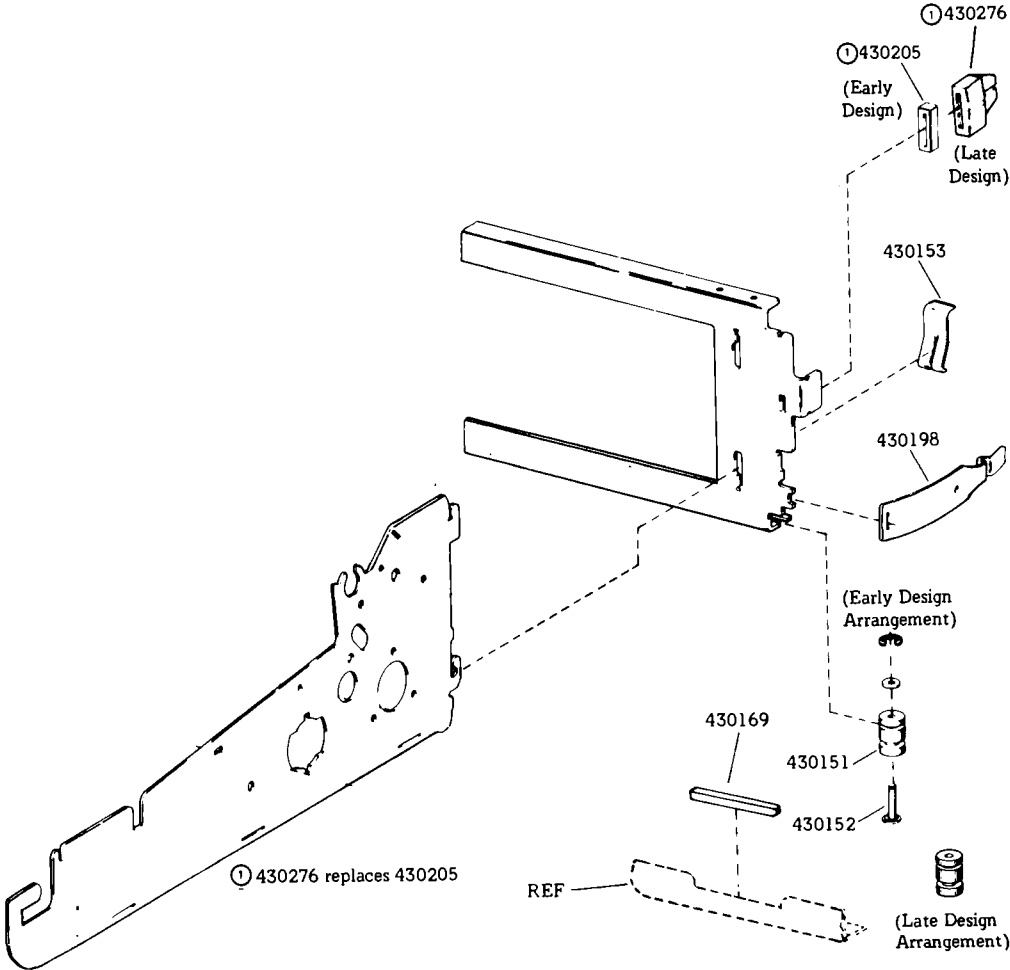

F. PARTS (Contd)

2. PARTS (Contd)

Paper Tray

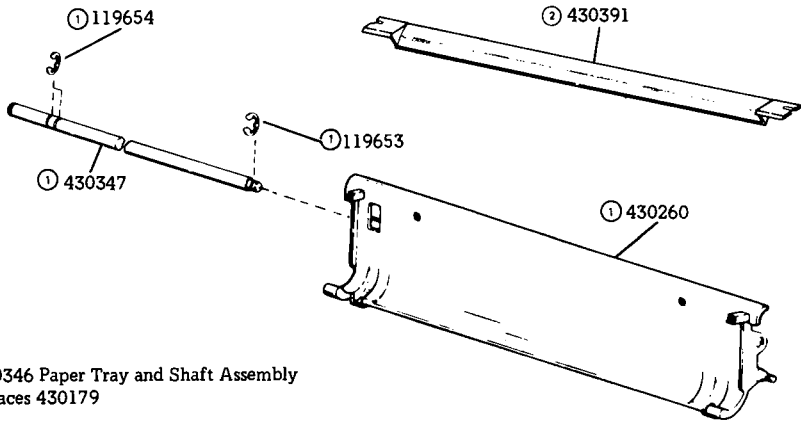

- ① Mod Kit 430346 Paper Tray and Shaft Assembly
- ② 430391 replaces 430179

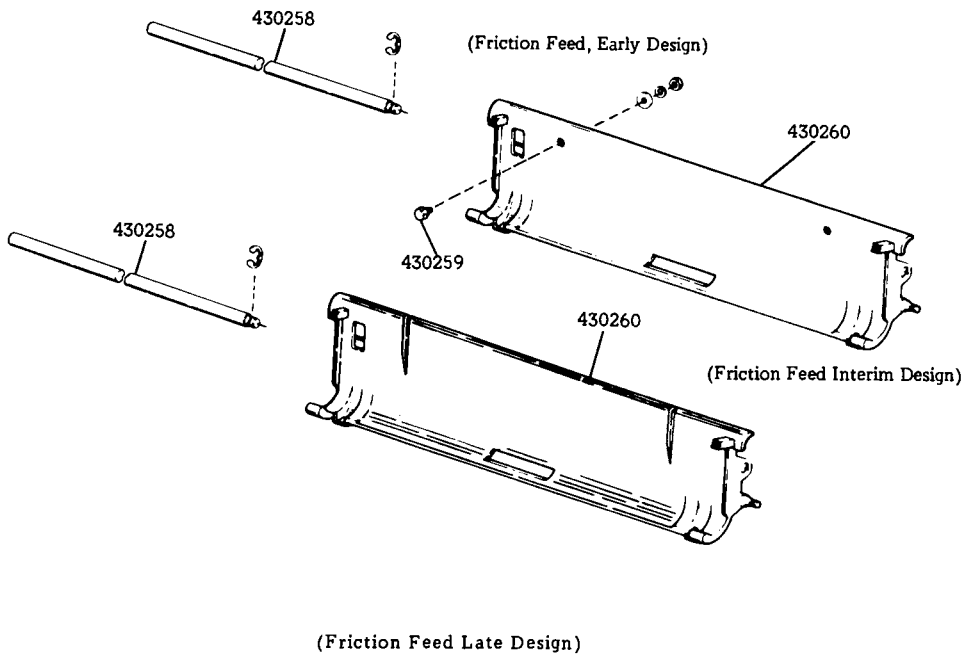

(Friction Feed Late Design)

Left Side Frame

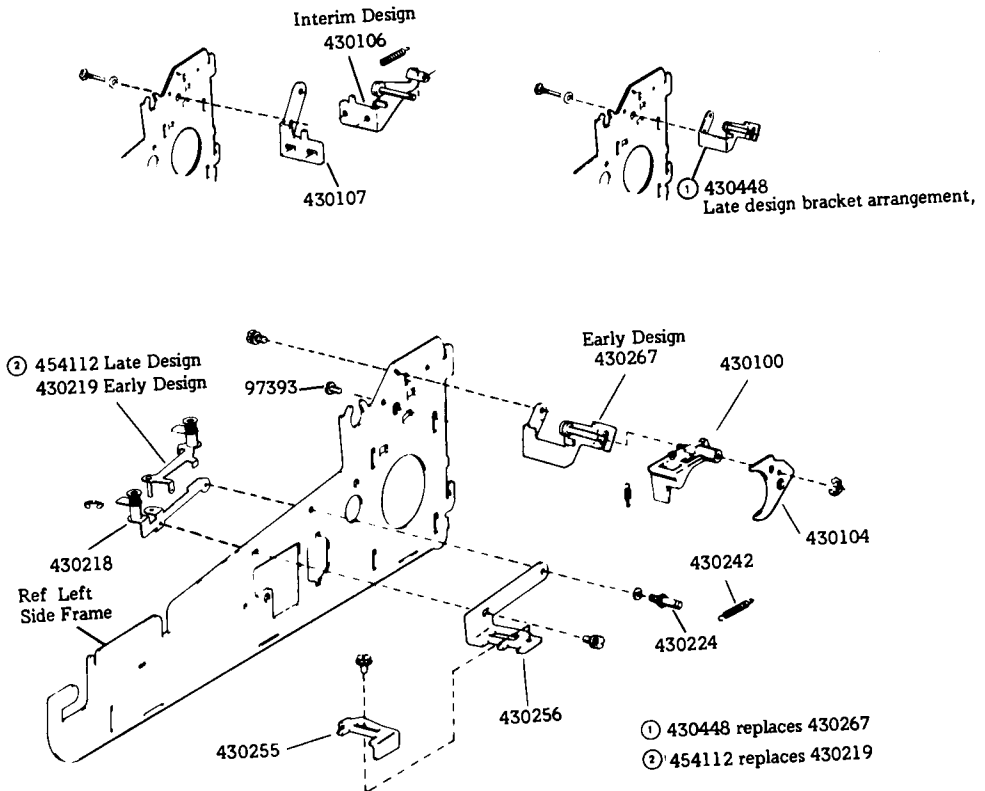

## F. PARTS (Contd)

3. NUMERICAL INDEX

Note: One space should be available in each maintenance area, unless otherwise specified in parentheses.

Part Number	Description and Page Number	Part Number	Description and Page Number	Part Number	Description and Page Number
97393	Screw 43	430117	Cable Assembly 38	430266	Shaft, Roller 40
119653	Ring, Retaining 42	* 430118	Spring, Compression 38	430267	Bracket, Left 43
119654	Ring, Retaining 42	* 430143	Pulley, 42T Platen 37, 38	430268	Bracket w/Posts 40
161708	Latch, Magnetic 40	* 430144	Pulley w/Flange, 24T 38	430276	Support, Bustle 41
163765	Ring, Retaining 37	* 430145	Belt, Timing 38	430281	Platen w/Spacers 37
181461	Gong 38	430151(2)	Mount, Rear 41	430285	Belt Timing 38, 39
184055	Screw, w/Lockwasher 38	430152(2)	Stud 41	430291	Separator, Paper 40
184067(3)	Screw w/Lockwasher 39	430153(2)	Clip 41	430309	Slot, Bushing 38
410013	Card Assembly 37	* 430154	Motor w/Cable 38	430319	Pulley w/Clip 39
430010	Rod, Guide 39	430166	Bracket, Bell 38	430346	Modification Kit 42
430013(2)	Bearing, Platen 37	430167	Bracket, Bell 38	430347	Shaft, Paper Tray 42
430016	Post, Lever 39	430169	Strip, Insulator 41	430351	Nut, Special 37
430017	Lever w/Stud 39	430178	Housing 39	430352	Nut, Special 37
* 430019	Roller w/Bearing 38, 39	430179	Guide 42	430366	Spring, Compression 37
430020(2)	Bearing, Housing 39	430180	Bracket, Right 40	430370	Platen 37
* 430021	Spring 38, 39	430190	Motor w/Cable 39	430391	Guide 42
430022	Post, Spring 39	430198(2)	Clamp 41	430398	Shim 38, 39
* 430026	Bearing, Outer 39	430199	Lever w/Stud 38	430399	Bearing 39
* 430027	Bearing, Inner 39	430205	Bumper 41	430404	Bushing 38
430028	Spring, Compression 38, 39	430206	Spacer 37	430406	Motor w/Cable 38
430029	Screw, Lead 38	430214	Pulley w/Clip 39	430408	Bracket, Bell 38
430030	Spring, Compression 37	430215	Carriage w/Post 37	430409	Coil Assembly 38
* 430031	Nut, Special 37	430216	Collar w/Link 37	430410	Spring 38
* 430033	Pulley, 81T 39	* 430217	Bridge Assembly 37	430411	Plunger 38
430034	Fastener 39	430218	Bracket Assembly, Left 43	430439	Modification Kit 39
430047	Motor w/Cable and Encoder 39	430219	Plate Assembly, Left 43	430440	Modification Kit 37, 38, 39
430055	Cable Assembly 39	430222	Washer, Felt 39	430441	Motor w/Cable and Encoder 39
430058	Cover 39	430224	Post, Spring 43	430445	Housing 39
430061	Disc, Encoder 39	430231	Shield, Ribbon 39	430446	Bracket 40
430063	Fastener 39	430240	Stud, Idler Bracket 38	430448	Bracket, Left 43
430068	Nut 8-32 Spl 37	430242	Spring 43	430625(5)	Support 38
430069	Handle, Locking 37	430253	Bracket, Stop 38	430803	Cable Assembly 37
430100	Guide, Left Paper 43	430255	Slide 43	430804	Insulator 37
430101	Guide, Right Paper 40	430256	Bracket 43	430829	Cover 37
430104(2)	Stripper, Paper 40, 43	430258	Shaft, Paper Tray 40, 42	430832	Switch 37
430106	Bracket w/Post, Left 43	430259	Stud, Paper Guide 42	* 430850	Head Assembly, Print 37
430107	Bracket, Left 43	430260	Tray, Paper 42	453152	Disc, Encoder 39
* 430113	Coil Assembly 38	430261	Bail, Roller 40	453240	Bell Assembly 38
430114	Plunger w/Pin 38	430262	Plate w/Post 40	454112	Plate Assembly, Left 43
		430264	Lever, Friction Feed 37		
		430265	Roller, Pressure 40		

\*A maintenance spare stocking ratio of one spare for the first twenty stations and one additional spare for each addition 30 stations in a maintenance area.

PART 3 — 42 BUFFERED KEYBOARD

INDEX

PAGE

A. TROUBLESHOOTING .....	3-1
B. WIRING .....	3-3
C. DISASSEMBLY/REASSEMBLY .....	3-4
D. PARTS .....	3-12



PART 3 -- 42 BUFFERED KEYBOARD

A. TROUBLESHOOTING

<u>CONTENTS</u>	<u>PAGE</u>
1. GENERAL .....	3-1
2. TROUBLESHOOTING GUIDE.....	3-2
1. GENERAL	
1.01 This part provides troubleshooting information for the Pedestal Based or Tabletop 42 Buffered keyboard.	
1.02 Keyboard troubleshooting is initiated by the 42 Buffered KSR and ASR Teleprinter Troubleshooting, Page 1-45 or when trouble in the keyboard is suspected from symptoms observed.	
1.03 Analysis in this part is limited to isolating the trouble within the keyboard up to its electrical interface at the logic card. The 42 keyboard must be tested as part of a 42 Buffered KSR or ASR Teleprinter. Refer to Page 1-63. Where analysis indicates the trouble is not in the keyboard, return to Part 1, D. TROUBLESHOOTING for further analysis.	
1.04 When a trouble is verified to be in the keyboard (by replacement of the key-	

board), Part 3 should be used to help isolate the trouble to any replaceable components to correct the trouble. The keyboard is returnable to the Teletype Product Service Center for repair as a unit 43K202/GAC or 43K202/GAD. Pack in carton (using conductive plastic bag) that was used to pack replacement keyboard. High voltage static discharge can damage keyboard circuitry. The 346392 wrist strap is available to ground service personnel.

1.05 Isolation and correction of troubles is based on electrical and mechanical checks and parts replacement.

Reference sections are:

- Page 3-3 Wiring
- Page 3-4 Disassembly/Reassembly
- Page 3-12 Parts

1.06 See 2. TROUBLESHOOTING GUIDE for trouble analysis presented in the form of a "20 Questions" routine. The guide, with questions and yes and no columns, should be used always starting with the first question and proceeding according to the "yes" or "no" directive.

A. TROUBLESHOOTING (Contd)2. TROUBLESHOOTING GUIDE

<u>QUESTION</u>	<u>YES</u>	<u>NO</u>
1. Does keyboard pass the keyboard test (see How To Operate Manual (WHEN TROUBLE OCCURS))?	Go to 2.	Go to 1a.
1a. Do any indicators light during keyboard test?	Check continuity of indicator that doesn't light. If defective replace. If ok go to 1b. If light doesn't turn off go to 1b.	Check Continuity of all leads of cable.  Replace keyboard.
1b. Exit test mode. Does keyswitch used to light or extinguish indicator, function properly (in LOCAL mode)?	Replace keyboard.	Replace keyswitch.
2. Does any keyboard key fail to generate the proper character or function?	Go to 2a.	Undefined trouble Go to Teleprinter Troubleshooting.
2a. Does the key fail in all modes?	Replace keyswitch. Replace keyboard.	Replace keyboard.

B. WIRING

CONTENTS

PAGE

1. GENERAL ..... 3-3

2. WIRING ..... 3-3

1. GENERAL

1.01 This part provides wiring information for the 42 Buffered Keyboard.

1.02 For additional wiring information, plug or cable locations, refer to Part 1, WIRING Page 1-56.

2. WIRING

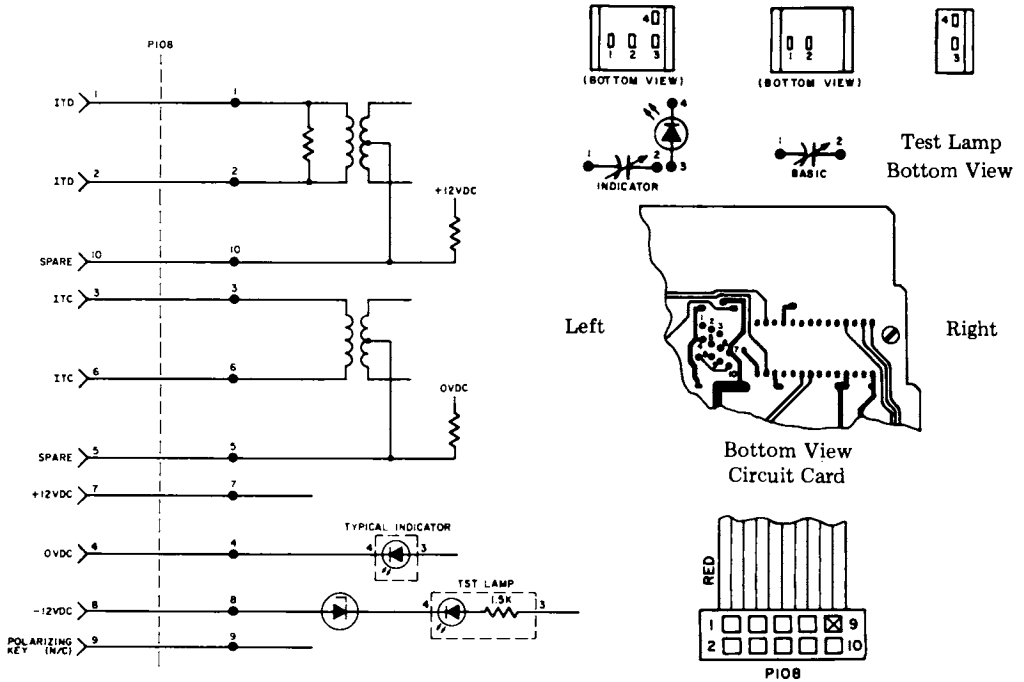

C. DISASSEMBLY/REASSEMBLY

<u>CONTENTS</u>	<u>PAGE</u>
1. GENERAL .....	3-4
2. TOOLS REQUIRED .....	3-5
3. DISASSEMBLY/REASSEMBLY . . .	3-5
Spacebar Mechanism .....	3-5
Keytop Removal .....	3-5
Keyswitch Removal .....	3-6
346927 Cable Removal .....	3-7
4. KEYPAD AND KEYSWITCH IDENTIFICATION .....	3-8
5. SPACER, HOUSING AND REFERENCE IDENTIFICATION ..	3-11

1. GENERAL

1.01 This part provides disassembly/reassembly procedures for the 42 Buffered Keyboard. (Fig. 1).

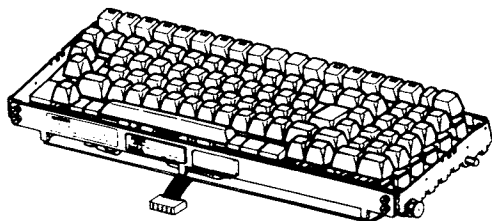

Fig. 1—43K202/GAC or 43K202/GAD

*Note:* When ordering replaceable components, unless otherwise specified, prefix each part number with the letters "TP" (ie, TP410324).

1.02 The keyboard circuitry can be damaged by static discharge. The 346392 static discharge ground strap is available for use by service personnel. Maintenance spares are provided in antistatic bags which should be saved for reuse when returning keyboards for repair.

1.03 The extent of the disassembly procedure is limited to that which is required for correction of troubles or replacement of parts in field locations. When removing a subassembly or part from the keyboard, follow the removal procedure and note the sequence of removal to enable proper reassembly.

1.04 Refer to Maintenance Tools, Section 570-005-800TC or 311B Bulletin for a complete listing of the various types of hand tools available for maintenance of Teletype Corporation equipment. For a listing of the tools required to perform the disassembly/reassembly of the 42 Buffered Keyboard, refer to 2. TOOLS REQUIRED.

1.05 Precautions should be taken to assure that the keyboard is disassembled and reassembled under clean conditions. No oil, grease, or other liquids shall be allowed on loose parts, subassemblies, keyswitches, or the complete keyboard.

1.06 Reference in the procedures to left or right and up or down and top or bottom, etc, refer to the keyboard in its normal operating position.

1.07 When removing a subassembly or part from the keyboard, do not force or pry parts to provide the necessary clearance for removal. No forcing is required to accomplish a removal procedure. Follow the removal procedure and note how each part is removed and the sequence of its removal so that proper reassembly can be accomplished. For reassembly, reverse the removal procedure except where different instructions are given.

1.08 Refer to Disassembly/Reassembly, Page 1-92 for keyboard removal and replacement procedures.

2. TOOLS REQUIRED

2.01 The following tools are recommended for use during the disassembly and reassembly procedures:

- 75765 Spring Hook — Pull
- 89954 1/4 Inch Nut Driver
- 100982 Screwdriver (6 Inch Medium)
- 108285 Long-Nose Pliers
- 346257 Keyswitch Extractor
- 346260 Keytop Extractor
- 346392 Static Discharge Strap
- Customer Provide Tools
- Soldering Iron (Low Wattage)
- Desolderer

3. DISASSEMBLY/REASSEMBLY

3.01 Spacebar Mechanism

(a) Disengage the leaf spring (bronze colored) from the wire bail using a spring hook and pull towards the front (Fig. 2).

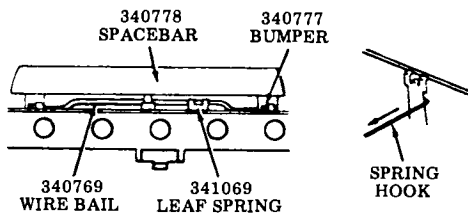

Fig. 2—Leaf Spring Disengagement

(b) Disengage the two rear tines (one at each end of spacebar) with a small screwdriver while pulling the spacebar up and toward the front (Fig. 3).

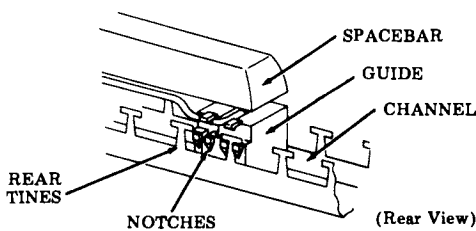

Fig. 3—Spacebar Removal

(c) Continue applying upward pressure to the spacebar and disengage the two front tines.

(d) Remove the wire bail from the left and right spacebar guides (snaps in and out) (Fig. 4).

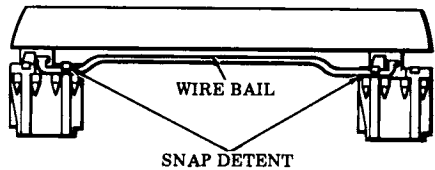

Fig. 4—Wire Bail Removal

(e) In reassembly, make sure the four tines engage the notches in the spacebar housing and the leaf spring is engaged to the wire bail.

(f) Check mechanical operation of the spacebar so that it returns to its unoperated position freely when depressed and released slowly.

3.02 Keytop Removal (Fig. 5)

(a) There are two types of keytops used on the keyboard.

- (1) Control Keytop
- Indicator
- Non-Indicator
- (2) Data Keytop



Fig. 5—Keytops

(b) To remove data keytops, place 346260 tool over the keytop and pull up to remove (Fig. 6).

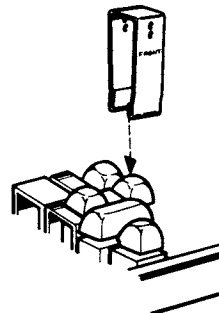

Fig. 6—Data Keytop Removal

### C. DISASSEMBLY/REASSEMBLY (Contd)

#### 3. DISASSEMBLY/REASSEMBLY (Contd)

##### 3.02 Keytop Removal (Fig. 5) (Contd)

(c) To remove control keytops (Fig. 7):

- (1) Grasp keytop using thumb and index finger.
- (2) Exert upward force until keytop releases.

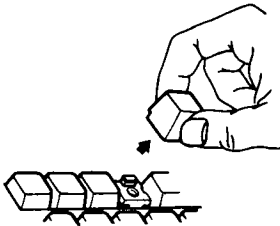

Fig. 7—Control Keytop Removal

(d) To remove the < keytop with housing.

- (1) Remove the keytops that surround the < keytop using 346260 tool.
- (2) Disengage the rear tines from housing with a small screwdriver while pulling < keytop up and toward the front (Fig. 8).

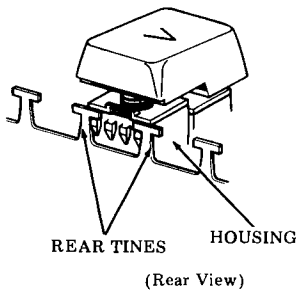

Fig. 8—Rear Tine Disengagement

(3) Continue applying upward pressure to the < keytop and disengage the front tine from housing using a spring hook. Remove keytop with housing from channel (Fig. 9).

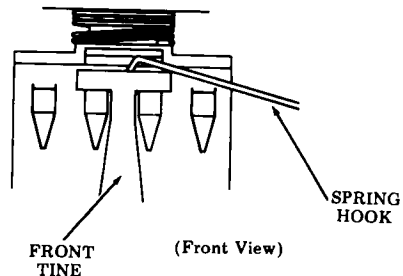

Fig. 9—Front Tine Disengagement

(4) In reassembly, insert housing with keytop; observe position of locating lug on housing and press into channel. Housing must snap fully into front and rear channel tines.

##### 3.03 Keyswitch Removal

- (a) Remove keytop.
- (b) Remove circuit card shield by removing the four screws securing it to the keyboard and cut cable tie securing loose end of cable to the opcon.
- (c) Remove solder from around terminal pins of keyswitch to be removed (Fig. 10).

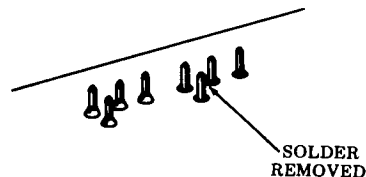

Fig. 10—Solder Removal

**Warning:** Use a grounded low wattage soldering iron (avoid prolonged contact with pins) along with a desoldering tool to prevent damage to keyswitch card circuits and components.

- (d) Place 346257 tool over the keyswitch and press downward. When the tool bottoms and embossed projections snap into notches on keyswitch, squeeze and pull back on the tool to lift keyswitch out (Fig. 11).

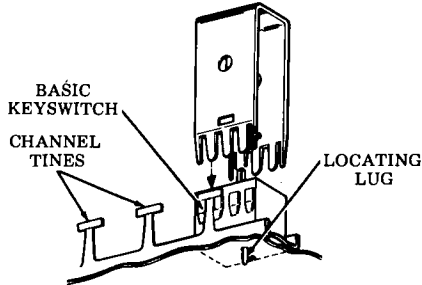

Fig. 11—Keyswitch Removal

*Note:* The tines of the tool must pass between the keyswitch housing and the inside of the tines on the channel.

- (e) In reassembly, insert new keyswitch, observe position of the locating lug, and press keyswitch into channel. Switch must snap fully into front and rear channel tines. Hold keyswitch in place and resolder.

### 3.04 346927 Cable Removal

- (a) Remove the keytops shown in Fig. 12.
- (b) Remove the keyswitches shown in Fig. 12.

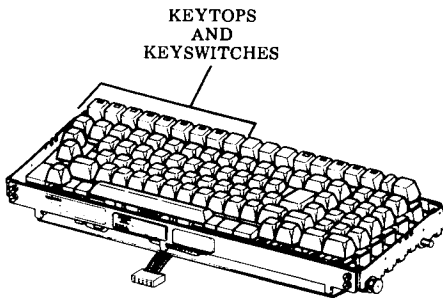

Fig. 12—Keyswitch Identification

- (c) Remove solder from around connector pins of cable to be removed (Fig. 13).

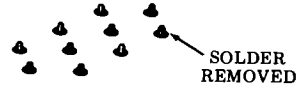
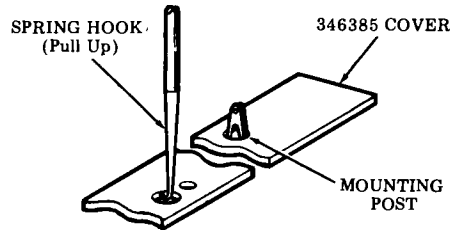

Fig. 13—Connector Pins

*Warning:* Use a grounded, low wattage soldering iron (avoid prolonged contact with pins) along with a desoldering tool to prevent damage to card circuits and components.

- (d) Remove the circuit card cover located in front of the control keys from the channel. Use a spring hook to remove the cover from the mounting posts (Fig. 14).



(Top View)

Fig. 14—Cover Removal

- (e) Grasp the cable and cable connector and exert upward force until cable connector releases.
- (f) Cut cable ties securing the cable to the circuit card.
- (g) Remove rear plate and left side frame. (Fig. 15).

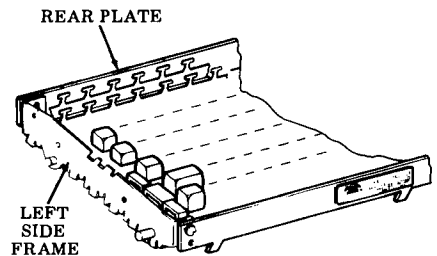

Fig. 15—Cable Removal

C. DISASSEMBLY/REASSEMBLY (Contd)

3. DISASSEMBLY/REASSEMBLY (Contd)

3.04 346927 Cable Removal (Contd)

- (h) Slide cable to the left until it clears the circuit card and remove.
- (i) In reassembly, insert new cable connector into circuit card holes and press into place. Route cable as shown in Fig. 16. Hold cable connector in place and resolder.
- (j) Replace circuit card shield.

- (k) Fold cable under circuit card then fasten cable to card using locally furnished cable tie. Fasten in two places. See Fig. 16.
- (l) Reassemble keyswitches and keytops removed in steps (a) and (b).
- (m) Replace circuit card cover removed in step (d).
- (n) Replace rear plate and left side frame.

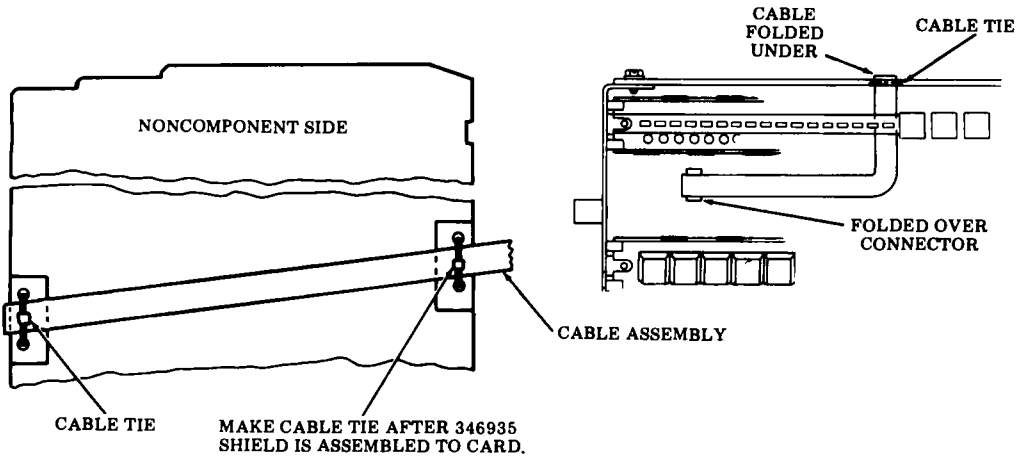

Fig. 16—Cable Replacement

4. KEYTOP AND KEYSWITCH IDENTIFICATION (Fig. 17, 18, 19 and 20)

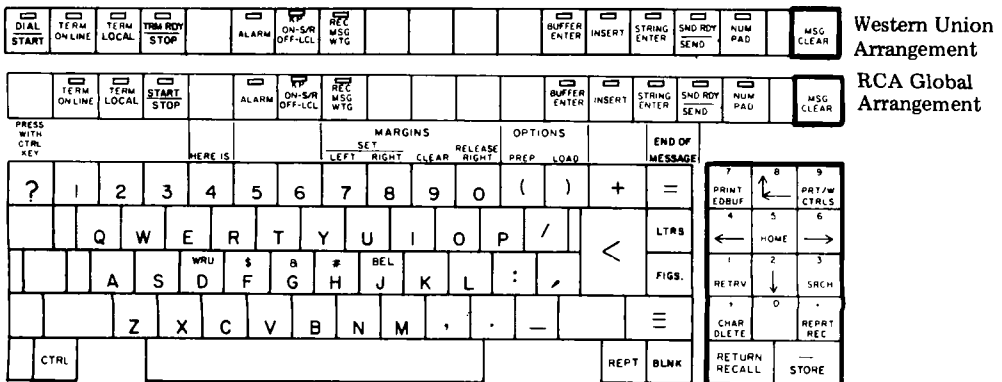

Fig. 17—Keyboard Layout (Pedestal Based)



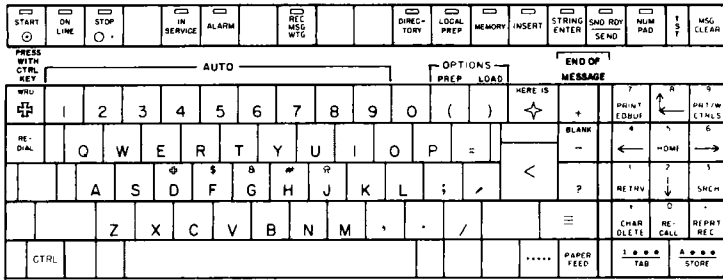

Fig. 18—Keyboard Layout (Tabletop)

PART NO.	KEYTOP DESCRIPTION		PART NO.	KEYTOP DESCRIPTION	
340701	BLOCKING — CONTROL		346163	ALARM	
340714	BLOCKING — DATA		346536	1	
340778	SPACEBAR		346537	2	
340861	;/;		346538	3	
340862	"/		346539	4	
340877	??/		346540	5	
340986	LINE FEED		346541	7	
340987	CTRL		346542	8	
340988	REPT		346543	9	
340990	6		346544	0 (ZERO)	
340993	Q		346548	,	
340994	W		346549	.	
340995	E		346550	/	(T)
340996	R		346558	M	
340997	T		346559	J	
340998	Y		346582	—	
340999	U		346591	7	PRINT EDBUF (P)
341000	I		346592	8	↑ (P)
341001	O (ALPHA)		346593	9	PRT/W CTRLS (P)
341002	P	(T)	346594	4	← (P)
341003	=		346595	5	HOME (P)
341005	D		346596	6	→ (P)
341006	F		346597	1	RETRV (P)
341007	G		346598	2	↓ (P)
341008	H		346599	3	SRCH (P)
341009	K		346600	'	CHAR DLETE (P)
341010	L		346601	.	O (PAD)
341012	Z		346602	.	REPT REC (P)
341013	X		346603	RETURN	RECALL
341014	C		346604	—	STORE
341015	V		346671	?	
341016	B		346675	(	
341017	N		346676	)	
341020	(BLANK SHIFT)		346677	+	(P)
346113	IN SERVICE		346678	=	(P)
			346680	/	(P)

\*The 340764 compression spring between the 346950 keytop and the housing must be ordered separately.  
 (P) = Pedestal based.  
 (T) = Tabletop.

Fig. 19—Keytop Identification

## C. DISASSEMBLY/REASSEMBLY (Contd)

## 4. KEYTOP AND KEYSWITCH IDENTIFICATION (Fig. 17, 18, 19 and 20) (Contd)

PART NO.	KEYTOP DESCRIPTION		PART NO.	KEYTOP DESCRIPTION	
346681	LTRS		347184	0/RECALL	
346682	A		347218	0/RETRV REC	
346683	S		347220†	7 PRINT EDBUF	(T)
346684	:		347221†	8 ↙	(T)
346685	/		347222†	9 PRT/W CTRLS	(T)
346686	FIGS		347223†	4 ←	(T)
346687	BLNK		347224†	5 HOME	(T)
346689	≡		347225†	6 →	(T)
346690	WRU	D	347226†	1 RETRV	(T)
346691	\$	F	347227†	2 ↓	(T)
346692	&	G	347228†	3 SRCH	(T)
346693	#	H	347229†	' CHAR DLETE	(T)
346694	BEL	J	347230†	0 RE-CALL	
346829	DIRECTORY		347231†	. REPRT REC	(T)
346839	TERM LOCAL		347232†	1 ... -- TAB	
346840	TERM ON LINE		347233†	A ... -- STORE	
346842	KP ON-SR OFF-LCL	(P)	347236	&	
346843	REC MSG WTG	(P)	347237	#	
346844	BUFFER ENTER	(P)	347238	!	
346845	INSERT	(P)	347239	\$	
346846	STRING ENTER	(P)	347240	BEL/S	
346847	SND RDY SEND	(P)	347241	FIGS/RECALL	
346848	NUM PAD	(P)	347242	LTRS/STORE	
346849	MSG CLEAR	(P)	347255		
346860	DIAL — START		454324	START ⊙	
346861	TRM RDY — STOP		454326	STOP ○	
346880	START — STOP	(P)	454327	LOCAL PREP	
346882	ON LINE		454328	MEMORY	
346950	<		454351	COPY SEND DATA	
347149	RETURN		454352	PRINT REC MSG	
347153	←		454353	LINE ACTIVE	
347169	WRU	⊕	454355	SND RDY	
347170	HERE IS	☆	454356†	REC MSG WTG	(T)
347171	REDIAL		454357†	DIREC - TORY	
347172	BLNK	—	454358†	MEMORY	
347176	⌞	J	454359†	INSERT	(T)
347177	PAPER FEED		454360†	STRING ENTER	(T)
347178	1 ... /TAB		454361†	SND RDY SEND	(T)
347179	A ... /STORE		454362†	NUM PAD	(T)
347180	⊕	D	454363†	MSG CLEAR	(T)
347181	?		454365	AUX REC	
347182	.....		454366	AUX READ	
347183	+	(T)	454367	AUX WRITE	

(P) = Pedestal based.

(T) = Tabletop.

† Orange keytops.

Fig. 19—Keytop Identification (Contd)

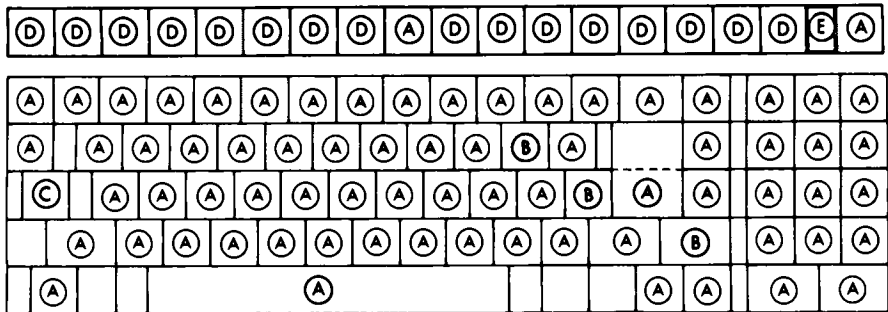

SWITCH NO.	TYPES	COLOR PUSH ROD
Ⓐ 340720	BASIC	WHITE
Ⓑ 340721	OVERTRAVEL	GREEN
Ⓒ 340722	LATCHING	BLACK
Ⓓ 346359	INDICATOR	ORANGE
Ⓔ 341088	INDICATOR ONLY	—

Fig. 20—Keyswitch Identification

5. SPACER HOUSING AND REFERENCE IDENTIFICATION

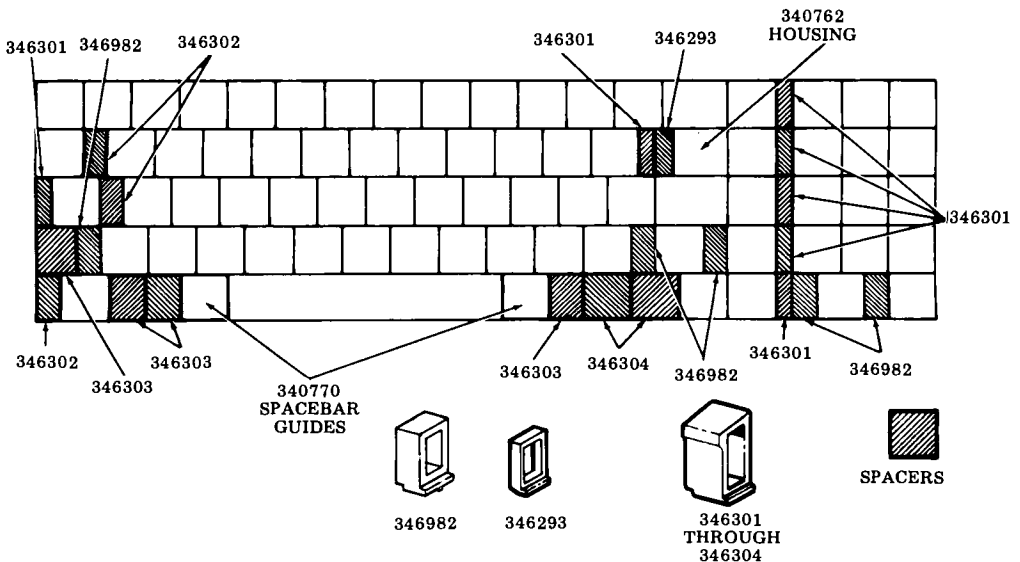

Fig. 21

D. PARTS

<u>CONTENTS</u>	<u>PAGE</u>
1. GENERAL .....	3-12
2. PARTS .....	3-12
3. NUMERICAL INDEX.....	3-13

in each maintenance area to correct troubles in the keyboard.

1. GENERAL

1.01 The parts in this part are maintenance spares for the 42 Buffered Keyboard. They should be available, in the quantities shown,

1.02 When ordering replaceable components, unless otherwise specified, prefix each part number with the letters "TP" (ie, TP410324).

1.03 Troubleshooting and disassembly/reassembly information for these parts is provided on Pages 3-1 and 3-4, respectively.

2. PARTS

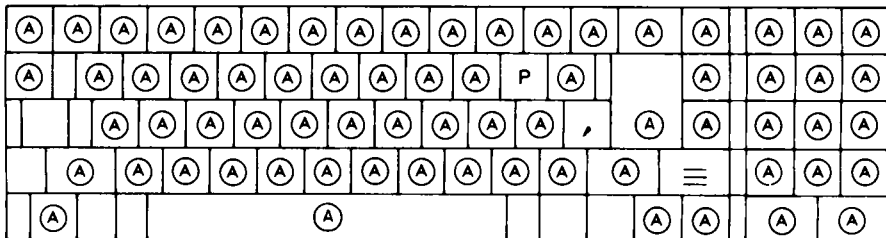
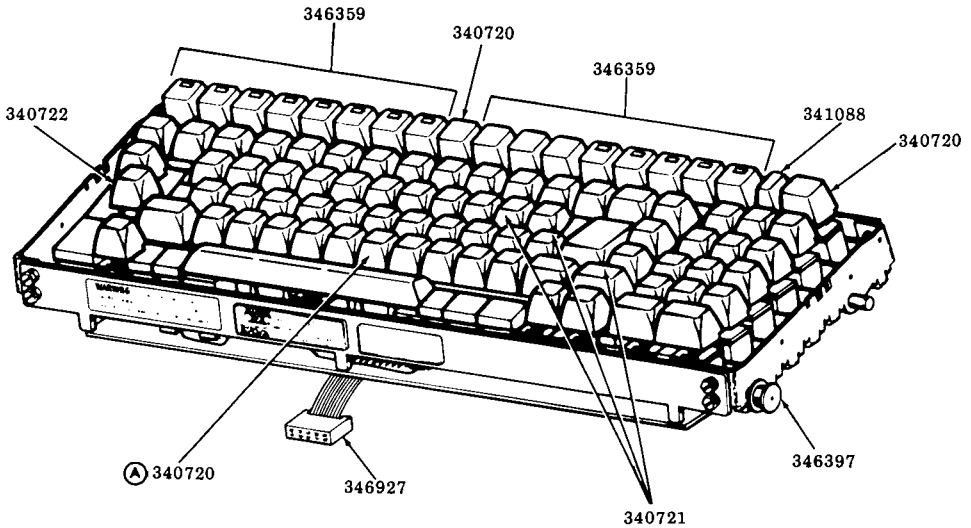

D. PARTS (Contd)3. NUMERICAL INDEX

<u>QTY PER MAINTENANCE AREA</u>	<u>PART NUMBER</u>	<u>DESCRIPTION</u>	<u>PAGE</u>
3	340720	Keyswitch	3-12
1	340721	Keyswitch	3-12
1	340722	Keyswitch	3-12
1	341088	Indicator Assembly	3-12
1	346359	Keyswitch	3-12
2	346397	Bushing	3-12
1	346927	Cable	3-12

PART 4 — 42 BUFFERED CONTROLLER

INDEX

PAGE

A. TROUBLESHOOTING .....	4-1
B. WIRING .....	4-5

PART 4 — 42 BUFFERED CONTROLLER

A. TROUBLESHOOTING

<u>CONTENTS</u>	<u>PAGE</u>
1. GENERAL .....	4-1
2. TROUBLESHOOTING GUIDE (Pedestal Based) .....	4-2
3. SELF-TEST PROCEDURES FOR CONTROLLER (Pedestal Based) .....	4-3
4. SELF-TEST PROCEDURES FOR CONTROLLER (Tabletop) .....	4-4

1. GENERAL

1.01 This part provides troubleshooting information for the pedestal based or tabletop 42 Buffered Controller.

1.02 Controller troubleshooting is initiated by the 42 Buffered KSR or ASR Teleprinter Troubleshooting, Page 1-45 or when trouble in the controller is suspected from symptoms observed.

1.03 Analysis in this section is limited to isolation of the trouble within the pedestal based controller and its associated power supply (up to its electrical interface to the KP set SSI circuit card) or to the tabletop controller card assembly. Refer to Page 1-60. Where analysis indicates the trouble is not in the controller (or its associated power supply), return to the Teleprinter, Part 1 for further analysis.

1.04 When ordering replaceable components unless otherwise specified, prefix each part number with letters "TP" (ie, TP430047).

1.05 The following Pedestal Based components are returnable to Teletype Product Service Centers for repair:

- 410705 IXL/EPROM Card
- 410291 CIU/SSI Circuit Card
- 410294 4K Memory Circuit Card
- 410297 16K Memory Circuit Card
- 410756 Telex Interface Card
- 430770 Power Supply

1.06 The following tabletop components are returnable to Teletype Product Service Centers for repair:

- 411901 Card Assembly
- 411907 16K Memory Controller  
Card Assembly
- 411959 Application Program  
Card (may be 411953)

1.07 Isolation and correction of troubles is based on electrical checks and parts replacement.

Reference sections are:

- Page 4-5 WIRING
- Page 1-92 DISASSEMBLY/REASSEMBLY
- Page 1-112 PARTS

1.08 A volt meter is required for measuring power supply voltages.

1.09 Trouble analysis for the Pedestal Based version is presented in the form of a "20 Questions" routine in 2. TROUBLESHOOTING GUIDE. The guide, with questions and yes and no column, should be used always starting with the first question and proceeding according to the "yes" or "no" directive.

1.10 Trouble analysis for the tabletop version is not required. Refer to 1.06 and the self-test provided in this part.

## A. TROUBLESHOOTING (Contd)

## 2. TROUBLESHOOTING GUIDE (Pedestal Based)

QUESTION	YES	NO
1. Is LED 2 lit on the IXL circuit card? (power cord to controller and KP set plugged in and power available, KP switch on) <p style="text-align: right;">(Top) (1) ○ (2) ● (3) ○</p>	Go to 2.	Go to 1a.
1a. Disconnect controller cable from power supply and measure at power supply for +12V dc, -12V dc and +5V dc.  Are any voltages present?	Go to 1c.	Check AC cord connection.  Check fuse F4 and replace if blown. Replace power supply if fuse blows again.  Replace power supply.
1c. Are all voltages present?	Go to 1d.	Replace power supply.
1d. Reconnect the controller cable to the power supply. remove all circuit cards from controller. Measure the voltages at the cable connection to the controller.  Are all voltages present?	Go to 1e.	Check continuity of cable. Replace if bad.  Replace back panel.
1e. Replace the controller circuit cards one at a time measuring the voltages at the controller after each card.  Are all voltages present?	Replace IXL card if LED 2 is not lit.  If LED 2 on IXL card is lit, check for intermittent short or open.	Replace circuit card that caused voltage to change.
2. Does controller pass self-test? (See Page 4-3 for self-test)	Refer to Teleprinter Troubleshooting Page 1-45 for further analysis.	Replace defective circuit card indicated by self-test.



3. SELF-TEST PROCEDURES FOR CONTROLLER (Pedestal Based)

3.01 The self-test should be performed when so directed by the response to questions in the Troubleshooting, Page 1-45 or Controller with Power Supply Troubleshooting.

3.02 Preliminary Notes

1. Information stored in the volatile memory will be lost when this test is performed.
2. Before initiating test, disconnect or turn off ac power to 430770 power supply and make sure all circuit cards are fully seated.
3. Position the normal-test switch on the 410756 Telex interface card to the test position.
4. During test, ignore any data that may print or keys that may light on the operator console.
5. To initiate test, with power off, depress and hold self-test switch on the 410705 ILX/EPROM card.

3.03 Test Procedure

1. With self-test switch depressed, apply ac power to 430770 power supply and observe LED pattern for Step 1 in Self-Test Chart. Release self-test switch.
2. For Step 1 and for each additional step, observe proper LED pattern for the time indicated followed by LED 2 flashing. Then, wait 5 seconds and go to the next step by depressing the self-test switch for at least 1/2-second.
3. If patterns for Steps 1 through 7 are correct, the controller and 430770 power supply are operating properly.

3.04 To terminate Self-Test

1. Disconnect or turn off power. Self-test switch must be released out. (If locked in, release by rotating 1/4-turn counterclockwise.)
2. Position the normal-test switch on the 410756 Telex interface card to the normal position.
3. Wait at least 3 seconds before applying power to resume normal operation.

SELF TEST PATTERNS FOR CONTROLLER			
(BEFORE PROCEEDING WITH TEST, REFER TO MANUAL 424 OR 425 FOR SELF TEST PROCEDURES)			
STEP	LED PATTERN	TIME BEFORE LED #2 STARTS FLASHING (INDICATES CARD PASSED TEST)	CARD TESTED
1	(1) ● TOP (2) ● (3) ●	1 SEC.	410705 (IN SLOT X04)
2	○ ● ●	1 SEC.	EPROMS ON 410705 (IN SLOT X04)
3	● ○ ●	55 SEC.	410294 W/STRAP S1 (IN SLOT X03) OR 410297 (IN SLOT X02)
4	○ ○ ●	82 SEC. (IF SLOT X02 IS EMPTY SEE NOTE)	410297 (IN SLOT X02)
5	○ ● ○	37 SEC. (IF SLOT X02 OR X03 ARE EMPTY SEE NOTE)	410294 W/O STRAP S1 (IN SLOT X03)
6	● ○ ○	1 SEC.	410297 (IN SLOT X03)
7	● ● ○	1 SEC.	410756 (MOUNTED TO CONTROLLER SIDE FRAME)
<p>SYMBOLS: ● LED "ON" ○ LED "OFF"</p> <p>NOTE: LED #2 WILL NOT FLASH. WAIT 5 SEC. AND PROCEED TO NEXT STEP. LED #2 IS LIT DURING NORMAL OPERATION.</p>			

### A. TROUBLESHOOTING (Contd)

#### 4. SELF-TEST PROCEDURES FOR CONTROLLER (Tabletop)

4.01 The self-test should be performed when so directed by the response to questions in the Troubleshooting Page 1-45.

#### 4.02 Preliminary Notes:

1. Information stored in the volatile memory will be lost when this test is performed.
2. During test, ignore any data that may print or keyboard keys that may light.
3. The controller self-test may be initiated in any teleprinter mode.

4.03 The controller LED, shown below, is used to indicate controller operation and the result of the self-test routine.

4.04 The round, black controller test switch actuator position is shown below.

#### 4.05 Test Procedure:

- (1) Note and record SPA7 switch positions. They must be returned to these positions at conclusion of test.
- (2) Place all SPA7 switches to the ON position.
- (3) Momentarily depress self-test switch (see figure below).

(a) The controller LED turns on and will flash periodically during the test (approximately 30 seconds) indicating the test is in progress.

(b) When the test is concluded, the LED will flash six times then flash once more and turn off indicating that the controller passed the self-test.

*Note:* Set SPA7 to original switch positions (see Step 1).

(4) If the self-test failed (LED remains ON), remove the application program card (refer to Part 1 DISASSEMBLY/REASSEMBLY procedures) from the controller assembly. Reassemble the controller without the application program card and place into the rear frame. Reconnect the cable plug to top of controller assembly. Place SPA7 switches as follows:

1 - OFF; 2, 3, and 4 - ON.

(5) Repeat the self-test.

(a) If the LED is ON at the end of this test, the application program card is defective and must be replaced.

(b) If the LED is OFF at the end of the test, the card assembly being test (411901) is defective and must be replaced.

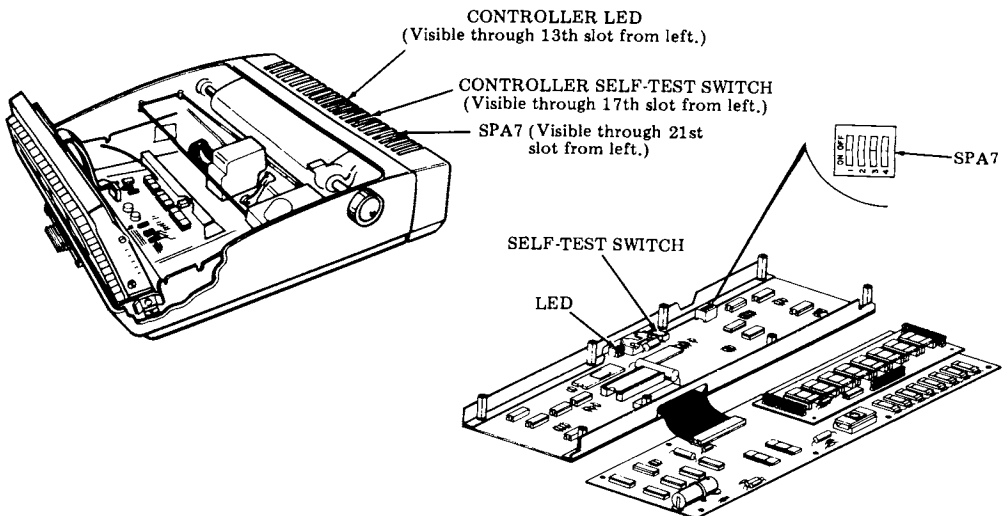

B. WIRING

CONTENTS

PAGE

1. GENERAL .....	4-5
2. WIRING (Pedestal Based) .....	4-5

1. GENERAL

- 1.01 This part provides wiring information for the Pedestal Based 42 Buffered Controller with Power Supply.
- 1.02 For additional wiring information, plug or cable locations, refer to Page 1-54, Terminal Wiring.

2. WIRING (Pedestal Based)

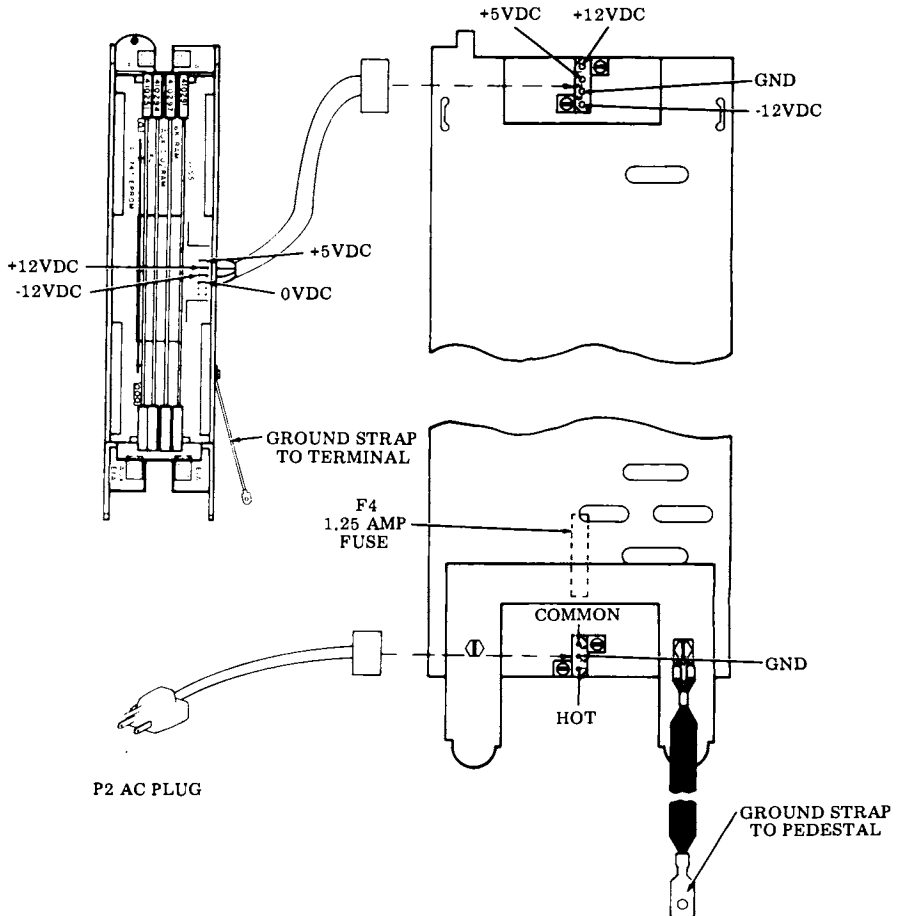

PART 5 — 42 BUFFERED PAPER HANDLING AND ENCLOSURES

	<u>INDEX</u>	<u>PAGE</u>
A.	ADJUSTMENTS .....	5-1
B.	PARTS .....	5-3

PART 5 — 42 BUFFERED PAPER HANDLING AND ENCLOSURES

A. ADJUSTMENTS

<u>CONTENTS</u>	<u>PAGE</u>	
1. GENERAL .....	5-1	1.03 After an adjustment is completed, tighten any screws or nuts loosened to make the adjustment.
2. TOOLS REQUIRED .....	5-1	1.04 Reference in the procedure to left or right, up or down, and top or bottom, etc, refer to the terminal in its normal operating position.
3. CABINET ADJUSTMENTS .....	5-2	1.05 Adjustments should be checked and performed when a trouble indicates a specific adjustment may be out of tolerance, or when an adjustment is disturbed to enable a part to be removed or replaced.
KEYBOARD TO COVER ALIGNMENT .....	5-2	
COLUMN INDICATOR POSITIONING .....	5-2	
1. <u>GENERAL</u>		2. <u>TOOLS REQUIRED</u>
1.01 This part provides adjustment information for the 42 Buffered Cabinet.		2.01 The only tools required to perform the cabinet adjustments is a 100982 screwdriver (1/4-inch, 6 inch blade) and a 129534 open-end wrench, 3/16 and 1/4 inch.
1.02 For PT (Paper Tape) unit, tape handling and enclosures adjustments, refer to Service Manual 422.		

A. ADJUSTMENTS (Contd)

3. CABINET ADJUSTMENTS

KEYBOARD TO COVER ALIGNMENT

The following two requirements must be met:

(1) Requirement

Left to Right Positioning – When the free play movement of the cover (left to right) is taken up lightly in each direction, the cover shall not touch any opcon keytops.

To Adjust

Loosen two screws and position the printer and rear frame assembly to meet the requirement.

(2) Requirement

Forward Positioning – The two front bushing clamps shall firmly engage the opcon bushings and hold the printer and rear frame assembly fully forward into the housing. There should be no front to rear play between the bushing and clamp (left and right sides).

To Adjust

Insert a screwdriver into the square hole in the nut plate and gently twist (or pry) the screwdriver with enough force to meet the requirement.

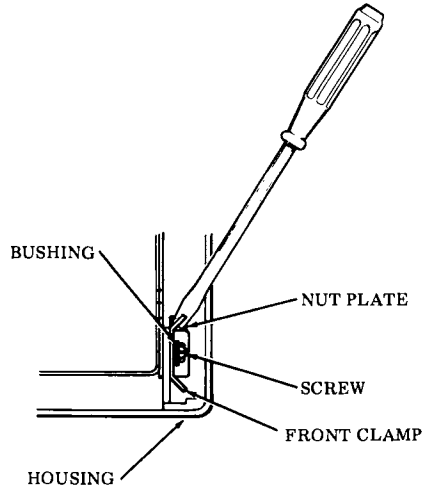

(Top View – Right Corner)

*Warning: Do not overtwist the screwdriver.*

COLUMN INDICATOR POSITIONING

Requirement

With power applied, the cover closed, and the print head positioned to column seven (7), the print head marker should point to the seventh mark on the indicator scale.

To Adjust

Reposition scale to meet the requirement.

*Note 1:* Various means are used to hold the indicator scale in position. If glue is present, gently remove, perform adjustment and reglue indicator scale using household cement or equivalent.

*Note 2:* This adjustment to be refined when making the KEYBOARD TO COVER ALIGNMENT adjustment.

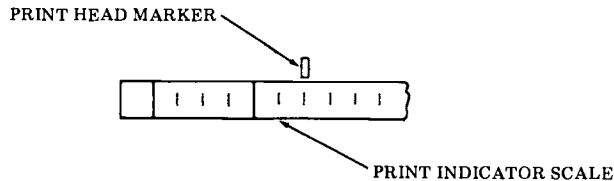

B. PARTS

CONTENTS

PAGE

1. GENERAL .....	5-3
2. PARTS .....	5-3
3. NUMERICAL INDEX .....	5-5

1. GENERAL

1.01 The parts in this part are maintenance spares for the 42 Buffered Paper Handling and Enclosures. They should be available in the quantities shown in each maintenance area to correct possible troubles or to meet appearance requirements of the 42 Buffered Cabinets.

1.02 All part numbers shown in this manual are Teletype Corporation part numbers.

1.03 Replacement of cabinet parts is specified in H. ROUTINE MAINTENANCE, Page 1-111. Disassembly/reassembly is specified in G. DISASSEMBLY/REASSEMBLY, Page 1-92.

1.04 For PT (Paper Tape) unit, tape handling and enclosures parts, refer to Manual 422.

2. PARTS

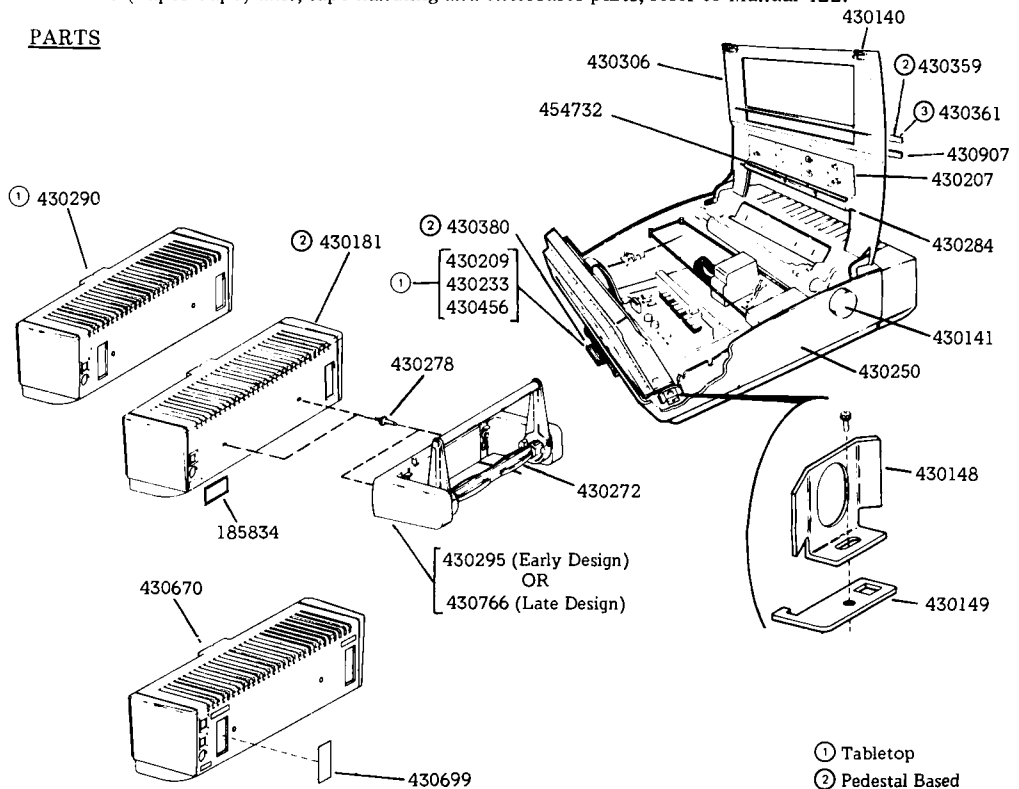

B. PARTS (Contd)

2. PARTS (Contd)

430295 and 430766 Paper Supply

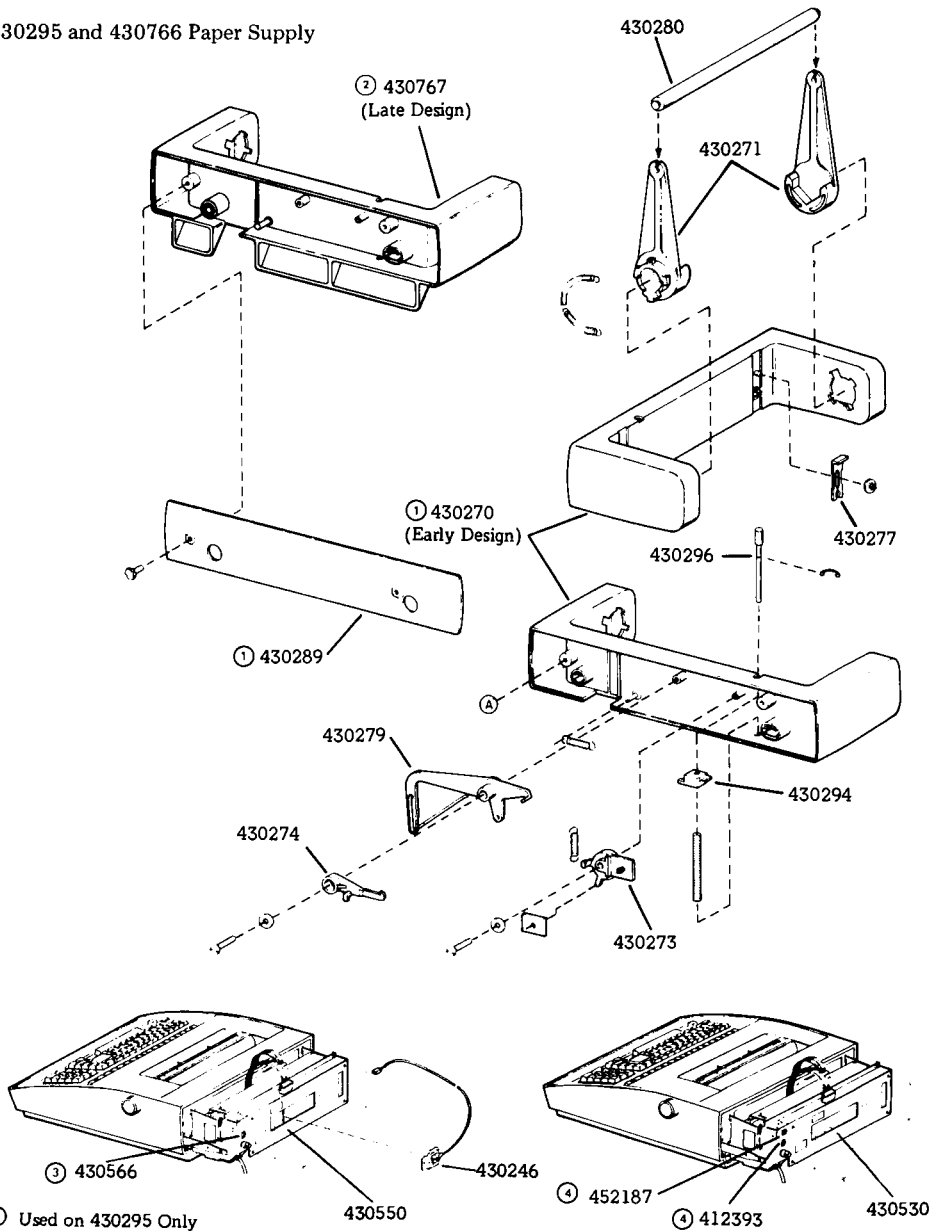

- ① Used on 430295 Only
- ② Used on 430766
- ③ Part of 430550
- ④ Part of 430530



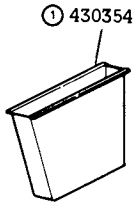
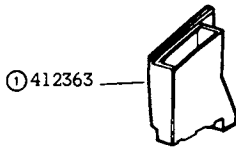

① Pedestal Based ASR Only

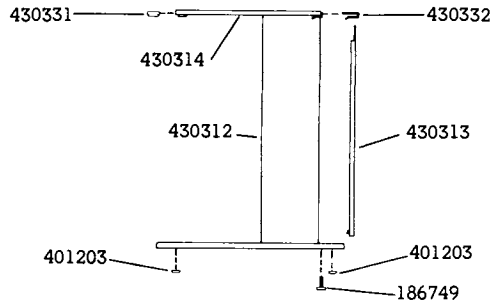

3. NUMERICAL INDEX

<u>QTY PER MTCR AREA</u>	<u>PART NUMBER</u>	<u>DESCRIPTION</u>	<u>PAGE</u>
1	185834	Plate, Fuse	5-3
2	186749	Bolt w/Cap	5-5
5	401203	Bumper	5-5
1	412363	Chad Chute Assembly	5-5
1	412393	Connector, AC	5-4
1	430140	Button	5-3
2	430141	Knob w/Insert	5-3
2	430148	Clamp	5-3
2	430149	Plate, Nut	5-3
1	430181	Bustle	5-3
1	430186	Nameplate, Teletype	5-3
1	430207	Label Instruction	5-3
1	430209	Card, Directory	5-3
1	430233	Label, Phone	5-3
1	430246	Assembly, Switch Bracket	5-3
1	430250	Housing w/Holder	5-3
1	430270	Support, Paper Roll	5-4
1	430271	Lever, Arm	5-4
1	430272	Spindle, Paper	5-3
1	430273	Cam, Low Paper	5-4
1	430274	Cam, Follower	5-4
1	430277	Latch	5-4
5	430278	Post	5-3
1	430279	Lever, Paper Sensor	5-4
1	430280	Roller, Paper	5-4
1	430284	Scale, 80-Column	5-3
1	430289	Plate, Rear Cover	5-4
1	430290	Bustle	5-3
1	430294	Lever, Reset	5-4
1	430295	Assembly, Paper Supply	5-3
1	430296	Shaft, Lever	5-4
1	430306	Cover, Friction	5-3
1	430312	Cabinet	5-5
1	430313	Panel, Rear	5-5
1	430314	Tray, Top	5-5
2	430331	Clip, Front	5-5
2	430332	Clip, Rear	5-5
1	430354	Box, Chad	5-5
1	430359	Label, "Press With Ctrl"	5-3

B. PARTS (Contd)3. NUMERICAL INDEX (Contd)

<u>QTY PER MTCE AREA</u>	<u>PART NUMBER</u>	<u>DESCRIPTION</u>	<u>PAGE</u>
1	430361	Label, "Press With Ctrl"	5-3
1	430380	Directory Card w/Labels	5-3
1	430456	Label, Option	5-3
1	430530	Rear Frame Assembly	5-4
1	430550	Rear Frame Assembly	5-4
1	430566	Switch, Rocker	5-4
1	430669	Plate, Cover	5-3
1	430670	Cover, Bustle	5-3
1	430766	Assembly, Paper Supply	5-3, 5-4
1	430767	Support, Paper Roll	5-4
1	430907	Label	5-3
1	452187	Switch, Rocker	5-4
1	454732	Label	5-3

Teletype Corporation Product Service and Education Services

On the following page is a list of Teletype Corporation Product Service locations which provide maintenance service and repair on all Teletype Corporation products. For more information call toll free (US 800-323-4226) (IL 800-942-4192) 7:00 A.M. - 4:00 P.M. CST.

In addition, Teletype Corporation provides customer technical training at its headquarters at 5555 W. Touhy Avenue, Skokie, IL in the northwest suburban area of Chicago. The training covers the installation, maintenance and repair of all Teletype Corporation products. Arrangements can also be made for training to be conducted at customer-selected field sites.

For information about class schedules, enrollment, tuition, on-site training or any special training needs, please contact:

Education Services  
Teletype Corporation  
5555 W. Touhy Avenue  
Skokie, Illinois 60077  
Telephone (312) 982-3940  
TLX 25-4051  
TWX 901-223-3611

**SERVICE CENTERS**

ALABAMA	BIRMINGHAM	230 OXMOOR CIRCLE SUITE 1113, HOMEWOOD, AL 35209	(205) 942-2574
	MOBILE	3207 INTERNATIONAL DR., SUITE B, MOBILE, AL 36606	(205) 473-8888
ARIZONA	PHOENIX	2113 S. 48TH ST., SUITE 104, TEMPE, AZ 85282	(602) 894-9891
	TUCSON	2015 N. FORTES BLVD., TUCSON, AZ 85705	(520) 723-6419
ARKANSAS	LITTLE ROCK	7501 INTERSTATE 30, SUITE 43, LITTLE ROCK, AR 72209	(501) 562-0286
CALIFORNIA	▲ LOS ANGELES	5445 SHEILA, CITY OF COMMERCE, CA 90040	(213) 728-2222
	OAKLAND	7305 EDGEWATER, SUITE C, OAKLAND, CA 94621	(415) 430-0202
	ORANGE COUNTY	11552 KNOTT, SUITE 9 GARDEN GROVE, CA 92641	(714) 891-2628
	SACRAMENTO	4221 NORTHGATE BLVD., NO. 4, SACRAMENTO, CA 95834	(916) 924-1933
	SAN DIEGO	7283 ENGINEER RD., SUITE B, SAN DIEGO, CA 92111	(714) 565-4375
	SANTA CLARA	3285 KIFER RD., SANTA CLARA, CA 95051	(408) 730-9083
	VENTURA COUNTY	2696 LAVERY COURT, SUITE 1, NEWBURY PARK, CA 91320	(805) 498-9655
COLORADO	COLORADO SPRINGS	905 GARDEN OF THE GODS RD., SUITE B, COLORADO SPRINGS, CO 80907	(303) 593-1222
	▲ DENVER	7100 BROADWAY, BUILDING 3-J, DENVER, CO 80221	(303) 429-9555
CONNECTICUT	HARTFORD	441 GOVERNORS HWY., SOUTH WINDSOR, CT 06074	(203) 568-8610
DIST. OF COLUMBIA	▲ LORTON, VA	9022 TELEGRAPH RD., LORTON, VA 22079	(703) 550-7507
FLORIDA	FT. LAUDERDALE	8658 N.W. 20TH AVE., FT. LAUDERDALE, FL 33309	(305) 974-4860
	JACKSONVILLE	6002 BOWDENDALE AVE., JACKSONVILLE, FL 32216	(904) 739-1170
	MIAMI	12802 S.W. 122ND AVE., MIAMI, FL 33186	(305) 252-1370
	ORLANDO	102 LIVE OAKS BLVD., CASSELBERRY, FL 32707	(305) 834 3818
	TAMPA	5474 JETPORT INDUSTRIAL BLVD., TAMPA, FL 33614	(813) 885-7413
GEORGIA	▲ ATLANTA	2520 PARK CENTRAL BLVD., DECATUR, GA 30035	(404) 981-7267
IDAHO	BOISE	172 S. COLE RD., BOISE, ID 83709	(208) 343-3629
ILLINOIS	▲ CHICAGO NORTH	2330 EASTERN AVE., ELK GROVE VILLAGE, IL 60007	(312) 860-5602
	▲ CHICAGO SOUTH	2900 21ST AVE., BROADVIEW, IL 60153	(312) 345-7920
	DECATUR	3501 RUPP PKWY., DECATUR, IL 62526	(217) 875-1092
	INDIANAPOLIS	6240 LAS PAS TRAIL, INDIANAPOLIS, IN 46268	(317) 255-4566
INDIANA	DES MOINES	8345 UNIVERSITY BLVD., DES MOINES, IA 50311	(515) 223-8444
IOWA	KANSAS CITY	6339 W. 110TH ST., OVERLAND PARK, KS 66211	(913) 383-3370
KANSAS	LOUISVILLE	3600 CHAMBERLAIN, SUITE 348, LOUISVILLE, KY 40222	(502) 426-4312
KENTUCKY	NEW ORLEANS	5626 JEFFERSON HWY., HARAHAN, LA 70123	(504) 773-4823
LOUISIANA	SHREVEPORT	5150 INTERSTATE P.O. 9128, SHREVEPORT, LA 71109	(318) 636-7104
	BALTIMORE	8980 ROUTE 108, COLUMBIA, MD 21045	(301) 796-1186
MARYLAND	BOSTON	131 FLANDERS RD., P.O. BOX 566, WESTBORO, MA 01581	(617) 366-8861
MASSACHUSETTS	OETROIT	12916 FARMINGTON RD., LIVONIA, MI 48150	(313) 525-5356
MICHIGAN	KALAMAZOO	126 E. KILGORE RD., KALAMAZOO, MI 49001	(616) 344-1944
	LANSING	3202 S. PENNSYLVANIA AVE., LANSING, MI 48910	(517) 384-6250
MINNESOTA	DULUTH	HWY 61 & CANOSIA RD., ESKO, MN 55733	(218) 878-1225
	MINNEAPOLIS	8824 SEVENTH AVE., NO., GOLDEN VALLEY, MN 55427	(612) 546-0060
MISSISSIPPI	JACKSON	137 TURN-POWE PLAZA, PEARL, MS 39208	(601) 932-1273
MISSOURI	ST. LOUIS	117766 WESTLINE INDUSTRIAL DR., ST. LOUIS, MO 63141	(314) 567-5910
NEBRASKA	OMAHA	13415 8 STREET BAY 2, OMAHA, NE 68144	(402) 330-3606
NEVADA	RENO	23 GLEN-CARRAN CIRCLE, SPARKS, NV 89431	(702) 356-8262
NEW JERSEY	▲ FAIRFIELD	90 CLINTON ROAD, FAIRFIELD, NJ 07006	(201) 576-6240
	EDISON	1245 ROUTE 1, EDISON, NJ 08817	(201) 494-8268
NEW MEXICO	ALBUQUERQUE	2820 BROADBENT PKWY., N.E., ALBUQUERQUE, NM 87107	(505) 345-1854
NEW YORK	ALBANY	4 NORMANSKILL BLVD., ELSMERE, NY 12054	(518) 482-9837
	BUFFALO	1505 CLEVELAND DR., CHEEK TOWAGA, NY 14225	(716) 634-7233
	LONG ISLAND	195 PARK AVENUE, BETHPAGE, NY 11714	(516) 822-3533
	MANHATTAN	42 BROADWAY, SUITE 1633, NEW YORK, NY 10004	(212) 785-2530
	ROCHESTER	115 METRO PARK, ROCHESTER, NY 14623	(716) 475-1740
	SYRACUSE	5 ADLER DR., EAST SYRACUSE, NY 13057	(315) 483-4666
NORTH CAROLINA	CHARLOTTE	11190 DOWNS RD., PINEVILLE, NC 28134	(704) 588-3297
	DURHAM	500 E. WILLIAMS ST., APEX, NC 27502	(919) 362-4469
	GREENSBORO	727 E. MOUNTAIN ST., KERNERSVILLE, NC 27284	(919) 996-4934
OHIO	CINCINNATI	4890 DUFF DR., SUITE E, CINCINNATI, OH 45246	(513) 874-2586
	CLEVELAND	5325 NAIMAN PKWY, SUITE F, SOLON, OH 44139	(216) 248-0288
	COLUMBUS	6969 WORTHINGTON, GALENA RD., WORTHINGTON, OH 43085	(614) 436-2065
	TOLEDO	1000 S. REYNOLDS RD., TOLEDO, OH 43615	(419) 381-9900
OKLAHOMA	OKLAHOMA CITY	1000 CORNELL PKWY., SUITE 700, OKLAHOMA CITY, OK 73108	(405) 947-0969
	TULSA	2002 S. 114TH EAST AVE., TULSA, OK 74128	(918) 437-2010
OREGON	PORTLAND	7950 S. W. CIRROS DR., BEAVERTON, OR 97005	(503) 641-9575
PENNSYLVANIA	HARRISBURG	4407-D CARLISLE PIKE, CAMP HILL, PA 17011	(717) 737-0405
	PHILADELPHIA	103 ROCK ROAD, HORSHAM, PA 19044	(215) 674-2181
	PITTSBURGH	780 PINE VALLEY DR., PITTSBURGH, PA 15239	(412) 325-4403
SOUTH CAROLINA	COLUMBIA	6007 TWO NOTCH RD., COLUMBIA, SC 29204	(803) 786-2927
TENNESSEE	MEMPHIS	1835 NONCONNAH BLVD., SUITE 121, MEMPHIS, TN 38132	(901) 346-8840
	NASHVILLE	222 N. STORY RD., SUITE 124, IRVING, TX 75061	(615) 254-0546
TEXAS	▲ DALLAS	8981 INTERCHANGE DRIVE, HOUSTON, TX 77054	(214) 254-4189
	HOUSTON	5605-A VILLA DRIVE, LUBBOC, TEXAS 79412	(806) 747-2225
	LUBBOC	4243 CENTER GATE, SAN ANTONIO, TX 78217	(512) 656-9370
	SAN ANTONIO	3650 W. 2100 SOUTH, SALT LAKE CITY, UT 84120	(801) 972-6332
UTAH	SALT LAKE CITY	5701-G GENERAL WASHINGTON DR., ALEXANDRIA, VA 22312	(703) 941-6202
VIRGINIA	LORTON (DC AREA)	5308-D VIRGINIA BEACH BLVD., NORFOLK, VA 23502	(804) 461-1778
	NORFOLK	8427 GLAZE BROOK AVE., RICHMOND, VA 23228	(804) 262-4062
	RICHMOND	635 STRANDER BLVD., SEATTLE, WA 98188	(206) 575-4515
WASHINGTON	SEATTLE	809 MAIN STREET, NITRO, WV 25143	(304) 755-3300
WEST VIRGINIA	CHARLESTON	324 W. WISCONSIN AVE., SUITE 3, APPLETON, WI 54911	(414) 731-1484
WISCONSIN	APPLETON	1806 WARDEN ST., EAU CLAIRE, WI 54701	(715) 832-4431
	EAU CLAIRE	3680 KINGSMAN BLVD., MADISON, WI 53704	(608) 249-5999
	MADISON	448 W. RAWSON AVE., OAK CREEK, WI 53154	(414) 764-6500
	MILWAUKEE	120 E. STEWART AVE., WAUSAU, WI 54401	(715) 845-8688
	WAUSAU	31 KLONDIKE DR., WESTON, ONTARIO, CANADA M9L 1S1	(416) 745-9474
CANADA	▲ TORONTO		

▲ REGIONAL OFFICES



## D R HOUSE TECHNICAL SERVICES

Don Robert House N.S.E.  
Graphic Designs and Technical Publishing

4716 Patty Lane  
Country Crossings  
Ringwood IL 60072

(815) 459-9861 iPhone  
(815) 653-0684 FAX  
drhouse42@iCloud.com  
[www.nadcomm.com](http://www.nadcomm.com)



TELETYPE CORPORATION  
5555 Touhy Avenue, Skokie, Illinois 60077

MANUAL 425  
Issue 2, June 1982