

# CHAPTER 10

## COAXIAL CABLES

### 10.1 GENERAL

The most common RF coaxial cable (figure 10-1) consists of a conductor supported and accurately centered in a tubular outer conductor by means of a dielectric. The dielectric physically and electrically separates the two conductors. The outer conductor may be covered by a protective jacket for protection from the elements, heat, cold, etc; a lead sheath for underwater or underground applications; or wire armor for maximum physical protection in dry locations. The cable may be flexible, semi-rigid, or rigid.

The center conductor may be solid or stranded copper wire, copper wire braid, or a tubular copper conductor, but other materials, such as nichrome, are also used for special purpose cables. Common dielectric materials are polyethylene, neoprene, and Teflon. The dielectric may be solid, semi-solid, or in the form of tapes wrapped around the center conductor.

The outer conductor usually consists of braided wires to permit flexibility, but solid outer conductors are also used. A jacket protects the cable from abrasion and the action of chemicals. Common jacket materials are synthetic rubber, polyethylene, and synthetic resin. Braided wires of aluminum or galvanized steel are used to form the armor protective covering; occasionally the armor is rubber coated for moisture proofing.

The standard impedance for RF coaxial cable at Naval shore stations is 50 ohms. MIL-HDBK-216, RF Transmission Lines and Fittings, contains the latest technical data of coaxial cables and the information contained therein will govern in the resolution of conflicting information.

### 10.2 FLEXIBLE/SEMI-RIGID CABLE

Flexible coaxial cable is the simplest, most versatile, and most widely used means of transmission of RF and microwave energy. The ability of the cable to withstand flexure about a prescribed minimum radius without physical damage or electrical deterioration, permits its extensive use in a variety of installations. The majority of the flexing stress is absorbed by the dielectric and outer jacketing materials.

Coaxial cable which can be formed into moderate bends during installation and which requires more precise care in handling, falls into the broad category of semi-rigid cable. The dielectric of a semi-rigid line may be either continuous solid insulation or an airspace structure. In the latter, a continuous ribbon or rod of dielectric material is spiralled openly with a uniform pitch around the center conductor to support it coaxially.

Table 10-1 contains a listing and technical characteristics of standard flexible and semi-rigid RF cable selected for use in military electronic equipment. Table 10-2 lists cable attenuation characteristics at several frequencies, and Table 10-3 contains references to assist in selecting connectors to use with specific cables. Figure 10-2 illustrates the various configurations of coaxial cable.

The following precautions should be exercised when installing flexible and semi-rigid cable:

- o Install cables in a way that will avoid areas of high temperature. When this is impossible, use Teflon dielectric cable.
- o Use as short a cable length as possible; the shorter the line, the less the attenuation.
- o Use as few separate sections of cable as possible to complete the run; the more connections made, the greater the attenuation.
- o If the equipment is shock-mounted, allow enough cable slack to permit unrestricted motion of the equipment.
- o When connecting cables to slide-mounted equipment, allow enough cable slack to permit withdrawal of the equipment.
- o Do not make sharp bends in the cable; the radius of the bend should always be at least 10 times the diameter of the cable, or in conformance with manufacturer's recommendations.
- o Use prefabricated, formed cable straps to support the cable; do not form straps by hammering over cable.
- o Do not use banding straps to support cables.
- o Do not cut or otherwise damage the jacket of the cable.
- o Use continuous lengths of cable (no connectors) for direct-burial applications, if possible. If not possible, couple cable lengths together in accessible locations, such as manholes and handholes.
- o Do not place stress on cables; always adequately support them.
- o Protect cables by use of grommets, sleeving, or tape where they may be subject to abrasion.

### 10.3 RIGID CABLE

The use of rigid coaxial cable, although largely replaced by solid dielectric flexible coaxial cable, has special application for permanent installations where ruggedness

and high power capacity are prime considerations. The word "rigid" refers to the coaxial cable sections, elbows, and accessories which are designed not to be bent nor formed at the installation site. The installation of rigid coaxial cable requires care and precision. This includes physical care of the cable's metallic tubes to prevent dents or other deformation causing degradation of the lines transmission characteristics. Two types of rigid cable are in use: bead supported and stub supported coaxial lines.

Bead supported coaxial are those in which the center conductor is supported and aligned by the use of low-loss dielectric beads within the outer shell. Although largely replaced by solid dielectric flexible coaxial cable, they still retain an advantage for permanent installations where ruggedness and high power capacity are prime considerations. They are available in many commercial sizes which have been found satisfactory for most applications.

Stub supported coaxial lines are those in which the inner conductor is supported and positioned within the outer shell by means of shorted stubs placed at strategic intervals along the line. Each stub is a quarter wavelength line shorted at the outer end, connected to the line both by center and outer conductors, and is oriented 90° to the direction of the main line. The stubs present a very high impedance in shunt with the line and introduce a negligible amount of power loss. Their main disadvantage is that a specific line can only be used over the very narrow band of frequencies for which the stubs are effectively a quarter wavelength.

Bead supported coaxial lines which mate with each of the stub supported sizes have been made or can be made. These lines, when constructed with properly designed undercut or overcut supporting beads, have broadband characteristics and can be used with, or as replacements for, stub supported lines. These lines have to date been made for special applications only.

Tables 10-4 through 10-7 list rigid transmission lines in use by the Armed Services.

#### 10.4 SPECIAL CABLES

Coaxial cables classified as special include those of a proprietary nature, peculiar in design, or that are used for special purposes. The instructions for installation and mating, published by the manufacturer, must be closely followed. Included in this category are delay lines and pulse, Styroflex (®), Spir-O-Line (®), and Heliax (®) cables.

##### 10.4.1 Pulse Cables and Delay Lines

The characteristics of common military pulse cables and delay lines are contained in table 10-1 with identification of the types noted in the engineering data column.

#### 10.4.2 Styroflex (R) Cable

Styroflex (R) cable consists of a solid, or tubular, copper inner conductor that is coaxially-supported in a seamless aluminum tube by a polystyrene-tape helix. A polyethylene jacket is applied to the cable to provide corrosion protection in underground installations; if required, an armored version is also available. Table 10-8 lists the characteristics of styroflex cables. Table 10-9 lists the attenuation and power ratings.

#### 10.4.3 Spir-O-Line (R) Cable

Spir-O-Line (R) cable consists of a copper center conductor that is supported and centered within an aluminum tubing outer conductor by six polyethylene tubes. No direct air path exists between the inner and outer conductors because of the compression of the polyethylene tubes. A polyethylene jacket is used to cover the outer conductor when direct burial is required. Table 10-10 lists the characteristics of these cables, attenuation and power ratings are listed in tables 10-11 and 10-12, respectively.

#### 10.4.4 Heliax (R) Cable

Heliax (R) coaxial cable is semiflexible, consisting of a corrugated copper outer conductor, a copper inner conductor, and either an air dielectric with a helically wound polyethylene strip insulator, or a foam dielectric consisting of expanded polyethylene foam. The air dielectric cable is maintained under a constant level air pressure while the foam dielectric cable is used in those applications in which non-pressurized service is desired. Teflon is used in place of the polyethylene strip insulator where an increase in power handling capability is required. Some cables come with a protective jacket for outdoor or buried applications. Table 10-13 lists the characteristics of Heliax (R) cable approved for military use. An approved method for installing these cables on connectors and flanges is detailed in paragraph 10.6.

### 10.5 CONNECTING COAXIAL CABLES TO TERMINALS

In certain cases it may be necessary to terminate coaxial cables (usually video and trigger cables) with solder terminals. This termination method minimizes the tendency of the connection to break as a result of cable movement and is accomplished as outlined below. It is recommended that the procedures be practiced on a piece of discarded cable of the same type to be used before the final connection is attempted, as the amount of solder to be used in the terminal barrel will vary for different cables and terminals. This practice may prevent damage to the permanently installed cable.

#### 10.5.1 Terminating Center Conductor

Step 1. Trim shield and insulation to permit inner conductor to protrude about one-eighth inch.

Step 2. Select a tubular solder terminal that has a barrel just large enough to fit over the center conductor.

Step 3. Heat terminal (A, figure 10-3).

Step 4. Slip heated terminal over center conductor. Push terminal into insulation surrounding center conductor until conductor bottoms (B, figure 10-3).

Step 5. Remove terminal. The insulation is now shaped to fit the terminal.

Step 6. Fill solder well of terminal about one-fourth full of melted solder.

Step 7. Continue to apply heat to terminal and insert center conductor of cable into barrel until conductor bottoms.

Step 8. Remove heat and allow solder to harden. To avoid damaging insulation, do not apply heat to terminal any longer than absolutely necessary. Do not move cable while solder is hardening.

Step 9. Take resistance measurements between shield and center conductor with a megger to determine if insulation has been damaged. The resistance reading should be close to infinity.

#### 10.5.2 Terminating Shield

In some applications it is necessary to terminate both the center conductor and the shield in solder terminals. The installation procedure for this termination would be the same up to this point. Additional steps are similar to those used for terminating the shield on shielded conductors; therefore, figure 7-30 is referenced in the following procedure.

Step 1. Determine how long shield must be to reach its termination point.

Step 2. Strip off the outer insulation. Be careful not to cut into shielding.

Step 3. While holding cable at the desired separation point, work shielding back and forth to loosen it.

Step 4. Spread braid at desired point and start a hole in shielding by using a scriber or other pointed object (Step 1, figure 7-30).

Step 5. Work scriber back and forth until hole is large enough to pull center conductor and insulation through.

Step 6. Push point of scriber under center conductor and pull it through hole (Step 2, figure 7-30).

Step 7. Twist loose strands of shield together (Step 3, figure 7-30).

Step 8. Solder end of shield to terminal. The completed termination should appear as shown in C, figure 10-3.

It should be noted that terminating a coaxial cable with solder terminals will change its characteristic impedance, the affect of this change becoming more noticeable at higher frequencies. Whether these changes impair circuit operation or not will depend on the specific application and must be determined at the time of installation design.

## 10.6 CONNECTING COAXIAL CABLE TO FLANGES

The following steps provide typical procedures for connecting coaxial cables to flanges. Because installation procedures will vary from flange to flange, the manufacturer's installation instructions should be closely followed.

10.6.1 Remove and check the contents of the package which contains the partially assembled connector plus standard loose items. Special inner connectors and additional parts are also included with each individual type connector. Be certain to keep all parts perfectly clean.

Prepare the cable (Step 1, figure 10-4). See that the end of the cable is cut evenly. If it is not, use a miter box and a hacksaw to make a new cut. The polyethylene jacket, outer conductor, and center conductor must be flush. After cutting, brush away all copper particles. Using a sharp linoleum knife, cut off the polyethylene jack 2-5/8 inches from the end of the cable. Clean the outer conductor. If there is difficulty in removing the flooding material, use a solvent like kerosene or gasoline. Next, file the cut edges of the conductors to remove any rough spots and to make them as square as possible. Sawing and filing should be done with the cable tilted downward. Hold the end of the cable downward and tap it vigorously to shake out any particles that may have entered.

10.6.2 Screw the clamping nut onto the cable. Then back it off, marking the position at which it came off. Mark both the cable and the connector with a pencil line. This will be a reference point for starting the clamping nut onto the cable. Add a thin coating of silicone grease (do not use ordinary grease) to the exposed outer conductor, large rubber gasket, and inside surface of the clamping nut for easier assembly. Place the large gasket at the end of the outer conductor (Step 2, figure 10-4). It may be turned inside out and peeled back over the outer conductor to avoid the sharp edges. With the pencil marks aligned, push the clamping body over the gasket and screw it onto the outer conductor until the threaded end exposes 3/16 inch of the outer conductor (Step 3, figure 10-4).

10.6.3 Using tin snips, make 3/16-inch cuts into the outer conductor at 3/8-inch intervals as shown.

10.6.4 Flare the outer conductor against the edge of the clamping nut. Use a rod and a ball peen hammer to aid in flaring. (See Step 4, figure 5-51.) Then, using the hammer alone, carefully tap the outer conductor flat against the clamping nut. Trim any portion of outer conductor that protrudes past the diameter of the clamping nut.

10.6.5 The inner conductor should extend 3/16 inch past the flared end of the outer conductor. Screw the stub at least 1/4 inch into the inner conductor. It must be clear of the tin snips when cutting the inner conductor. The stub has an internal or external left hand thread for connecting to the inner connector assembly. (See Step 11, figure 10-4.)

10.6.6 Using tin snips, cut about twelve 45-degree V notches, 3/16 inch deep, into the inner conductor (Step 6, figure 10-4).

10.6.7 Back the stub out of the inner conductor until its tapered edge is even with the deep points of the notches. Use the screw driver to fold the cut sections over the taper (Step 7, figure 10-4). With the hammer, carefully tap the cut sections in place.

10.6.8 Add the tiny "O" ring, inner flare ring, ring support, bead, small "O" ring and inner connector. Apply a thin coating of silicone grease to the tiny "O" ring and place it into the "O" ring groove in the stub. Add the inner flare ring to the stub (Step 8, figure 10-4). Next, apply silicone grease to the small "O" ring and place it into the "O" ring groove in the inner connector. Place the bead onto the recessed portion of the center connector. With the ring support held against the flared portion of the outer conductor, screw the inner connector (with "O" ring and bead attached) to the stub. Using a 1-3/16-inch wrench, tighten the inner connector to the stub.

10.6.9 Add silicone grease to the large "O" ring and place it into the groove in the clamping nut. Apply silicone grease to the medium "O" ring and place it into the groove in the outer body. (See Step 9, figure 10-4.)

10.6.10 Refer to Step 10, figure 10-4. Screw the appropriate center connector assembly to the stub and tighten it firmly against the folded edges of the inner conductor. Turn left to tighten. The connection has left hand threads. Use a 11/16-inch wrench against the flat portion in the recess of the inner connector assembly to tighten the connection.

10.6.11 Add a coating of silicone grease to the small "O" ring gasket and slip it onto the inner connector. Next, add a coating of silicone grease to the medium "O" ring gasket and slip it onto the front insulator in the groove provided. (See Step 11, figure 10-4.) Slide the insulator with "O" ring over the center connector and small "O" ring gaskets.

10.6.12 Gently place the inner adapter into the base of the connector on the outer body, and engage it with the inner conductor. (See Step 12, figure 10-4.) Use a right turning motion to aid the engagement. Align the keyway in the insulator with the

keyway in the connector, then push the adapter toward the outer body. Align the key on the end plug with the keyways in the insulator and connector base, then slide the plug into position. Tighten it in place with the locking nut. (See Step 13, figure 10-4.)

10.7 CABLE IDENTIFICATION

Each interconnecting cable shall be permanently marked by placement of an approved type of cable tag near each cable termination. Cable tags shall be placed near the jack, plug, or terminal board to which the cable terminates, in a prominent manner such that associative identification is obvious.

Table 10-1. Solid Dielectric RF Cables, Flexible

Type	Inner conductor	Dielectric material <sup>L/</sup>	Nominal diameter of dielectric	Number and type of shielding braid	Protective covering <sup>L/</sup>	Nominal over-all diameter	Weight	Nominal impedance	Nominal capacitance	Maximum operating voltage	Engineering data
RG-295/U	0.195 inch copper	A		Copper single braid	Neoprene	0.894					
RG-296	7/0.0336 silver covered copper	Silicone rubber		Silver covered copper single braid	Neoprene	1.190		50.0	35.4	10,000	
RG-298/U	7/0.211 inch Copper-clad	A			Foamed Polyethylene	0.650					Unshielded Buoyant Cable
RG-301/U	7/0.0203 inch Kerns Wire	F-1	0.185	Kerns Wire Single Braid	IX	0.245		50.0	29.0	3,000	Similar to RG-126/U
RG-302/U	0.025 inch Silver covered copper covered steel	F-1	0.146	Silver covered copper single braid	IX	0.206		75.0	21.0	2,300	Similar to RG-140/U
RG-303/U	0.039 inch Silver covered copper covered steel	F-1	0.116	Silver covered copper single braid	IX	0.170		50.0	28.5	1,900	Similar to RG-141/U
RG-304/U	0.059 inch Silver covered copper covered steel	F-1	0.185	Silver covered copper double braid	IX	0.280		50.0	28.5	3,000	Similar to RG-143A/U
RG-307/U	1-conductors 19/0.006 inch silver covered copper	Foamed polyethylene		Silver covered copper single braid	III	0.270		75.0		400	Interlayer is polyvinyl chloride
RG-316/U	7/0.0067 inch silver covered annealed copper covered steel	F-1	0.060	Silver covered copper single braid	IX	0.102		50.0		1,200	High temperature similar to RG-108A/U
RG-325/U	19 Strand silver plated copper wire	F-2	0.254	Silver plated copper braid	IIIA	0.465 max.		50.0			
RG-326/U	19 Strand silver plated copper wire	F-2	0.550	Silver plated copper braid	IIIA	0.779 max.		50.0			
RG-327/U	19 Strand silver plated copper wire	F-2	0.890	Silver plated copper braid	IIIA	1.18 max.		50.0			

<sup>L/</sup> Dielectric material  
 I - Polyethylene  
 A - Polyisobutylene  
 C - Synthetic-rubber compounds  
 D - Layer of non-conducting synthetic rubber between thin layers of conducting rubber.  
 E - Layer of conducting rubber plus two layers of non-conducting synthetic rubber.

AIAG 650

NOTE

The above partial table is a representative portion of the "Solid Dielectric RF Cables" table which appears in MIL-HDBK-216, 18 May 1965.



Table 10-2. Nominal Attenuation of RG/U Cable  
(Sheet 1 of 2)

RG/U CABLE	NOM. ATTENUATION db/100 Ft. at the Following Frequencies MMz									
	1	10	50	100	200	400	1000	3000	5000	10000
5,6,6A	-	-	-	2.7	4.2	6.4	11.3	22.0	30.0	43.0
5A,5B,212	.24	.78	1.8	2.6	3.9	5.5	9.1	17.8	25.0	-
7	.18	.64	1.6	2.4	3.5	5.2	-	-	-	-
8,8A,10,10A,213,215	.15	.55	1.33	2.0	3.5	4.6	8.0	16.5	27.0	-
9	.16	.57	1.38	2.0	2.9	4.25	7.3	15.5	23.0	36.0
9A,9B,214	.175	.61	1.47	2.1	3.2	5.0	9.0	18.0	25.0	38.0
11,11A,12,12A,13,13A,216	.187	.66	1.59	2.3	3.25	4.75	7.8	16.5	26.5	-
14,14A,17,17A,217,224	.12	.41	.98	1.4	2.05	3.10	5.5	12.4	19.0	51
17,17A,18,18A,177,218,219	-	.24	.62	.95	1.5	2.4	4.4	9.5	15.3	-
19,19A,20,20A,220,221	-	-	-	.69	1.12	1.85	3.6	7.7	-	-
21,21A,222	1.48	4.4	9.3	13.0	18.0	26.0	43.0	85.0	-	-
22	-	-	-	4.6	6.2	8.7	-	-	-	-
22B,111,111A	-	-	-	3.9	5.6	7.7	12.0	25.0	-	-
23A,24A	-	-	-	-	-	5.2ea.	-	-	-	-
25,25A,26,26A	-	-	-	-	-	-	-	-	-	-
27A,28B,64,64A,88,88A	.7	-	-	-	-	-	-	-	-	-
29	-	1.20	2.95	4.4	6.5	9.6	16.2	30.0	-	-
34,34A,34B	-	-	.85	1.4	2.12	3.28	5.85	16.0	-	-
35,35A,35B,164	-	.235	.58	.85	1.27	1.95	3.5	8.6	15.5	18.0
54,54A	-	-	-	3.2	4.7	6.8	11.5	25.0	-	-
55,55A,55B,223	-	1.2	3.2	4.8	7.0	10.3	16.7	30.7	46.0	130
57,57A,130,131	-	-	-	-	-	6.0	-	-	-	-
58,58B	.33	1.25	3.13	4.6	6.9	10.4	17.8	37.5	60.0	-
58A,58C	-	-	-	6.0	9.0	13.5	24.0	54.0	83.0	247
59,59A,59B	.335	1.07	2.4	3.4	4.85	7.0	12.0	26.5	42.0	-
62,62A,71,71A,71B	.25	.85	1.9	2.7	3.8	5.3	8.7	18.5	30.0	83.0
62B	-	-	-	-	-	7.3	-	-	-	-
62C,317	-	-	-	-	-	8.0	-	-	-	-
63,63B,79,79B	-	.62	1.39	1.99	2.8	4.0	6.4	12.2	-	-
65A	5.4	21.2	-	-	-	-	-	-	-	-
81	-	-	-	-	-	5.5	-	-	-	-
82	-	-	-	-	-	3.5	-	-	-	-
84A,85A	-	-	-	-	-	2.8	-	-	-	-
87A,116,165,166,225,227	.18	.60	1.42	2.07	3.05	4.45	7.60	15.0	21.5	36.5
94	-	-	-	2.2	3.3	5.0	9.0	20	-	-
94A,226	-	-	-	-	-	3.5	-	-	-	-
108,108A	-	-	-	-	-	16.8	-	-	-	-
114,114A	.95	1.34	2.05	2.9	5.4	-	-	-	-	-
115,115A,235	.17	.59	1.4	2.05	3.0	4.4	7.3	14.0	20.0	33.0
117,118,211,228	-	.245	.61	.90	1.35	2.4	3.55	7.6	12.0	38.0
117A,118A	-	-	-	-	-	2.9	-	-	-	-
119,120	-	.43	1.2	1.5	2.2	3.25	5.6	11.8	17.8	56.0
122	.4	1.7	4.48	7.0	10.8	16.5	29.0	57.0	-	-
125	-	.49	1.1	1.6	2.3	3.4	5.7	13.4	-	-
126,301	-	-	-	-	-	-	70	116	-	-
133A	-	-	-	-	-	5.7	-	-	-	-
140,302	-	-	-	3.3	4.7	6.9	12.8	26.0	-	-
141,141A,142,142A,142B,303	.34	1.13	2.68	3.85	5.6	8.5	13.8	27.0	39.0	70.0
143,143A,304	.25	.83	1.9	2.8	4.0	5.8	9.6	18.2	25.5	42.0

AIAG 653

Table 10-2. Nominal Attenuation of RG/U Cable  
(Sheet 2 of 2)

RG/U CABLE	NOM. ATTENUATION dB/100 Ft. at the Following Frequencies MHz									
	1	10	50	100	200	400	1000	3000	5000	10000
144	-	-	-	1.8	2.6	3.9	6.9	14.8	-	-
149, 150	-	-	-	-	-	8.5	-	-	-	-
156	.21	-	-	-	-	-	-	-	-	-
157	.19	-	-	-	-	-	-	-	-	-
158	.20	-	-	-	-	-	-	-	-	-
161	-	-	-	-	-	17.4	-	-	-	-
174	2.3	3.9	6.6	8.9	12.2	17.4	30.0	64	99	190
178, 178A, 196	2.6	5.6	10.2	13.8	19.5	28	46	76	114	170
178B	-	-	-	-	-	29.0	-	-	-	-
179, 179A, 187	3.0	5.3	8.1	10.0	12.6	16.0	24	44	64	139
179B	-	-	-	-	-	21.0	-	-	-	-
180, 180A	2.4	3.3	4.6	5.7	7.6	10.8	17	35	50	88
180B	-	-	-	-	-	17.0	-	-	-	-
181	-	-	-	-	-	6.0 ea.	-	-	-	-
188, 188A, 316	3.1	6.0	9.6	11.4	14.2	16.7	31	60	82	136
190, 329	.40	-	-	-	-	-	-	-	-	-
191, 230, 328	50	-	-	-	-	-	-	-	-	-
192	.26	2.0	-	-	-	-	-	-	-	-
193, 194	.20	1.0	-	-	-	-	-	-	-	-
195, 195A	-	2.2	-	6.6	9.5	13.3	22.5	46.0	-	-
197, 232	-	.14	.32	.4	6	1.0	11.0	13.5	15.0	-
209	-	-	-	-	-	2.5	-	9.4	-	-
210	-	-	-	-	-	7.0	-	-	-	-
211A, 228A	-	-	-	-	-	2.3	-	10.0	-	-
231, 331, 334, 335	-	-	-	-	-	2.3	4.2	-	-	-
233, 240	-	.07	.16	.25	.33	.5	.9	2.0	-	-
234, 242	-	.035	.09	.13	.2	.29	.5	-	-	-
236, 237	-	.125	.16	.19	1.2	1.8	3.0	6.0	8.0	14.0
244, 245	-	.24	.51	.8	1.1	1.7	2.7	4.5	6.0	-
252, 253	-	.23	.51	.9	1.2	1.8	2.8	5.0	7.7	10.2
254, 255	-	.13	.27	.38	.55	.85	1.5	2.3	4.5	-
257, 258, 270, 319	-	.06	.15	.22	.31	4.5	.8	1.8	-	-
264B, 264C	-	-	-	-	-	12.0	-	-	-	-
265	-	.06	.11	.18	.27	.58	1.0	-	-	-
267	-	.12	.3	.47	.68	1.0	1.7	3.0	-	-
268	-	.27	.6	.89	1.4	1.8	2.8	5.0	7.2	12.5
269, 318	-	.12	.28	.40	.6	.85	1.5	2.6	-	-
280	-	-	1.1	-	2.35	3.5	6.0	11.0	-	-
281	-	.23	.8	1.2	1.8	2.5	4.1	8.0	-	-
293	-	-	-	-	-	5.0	-	16.0	-	-
293A	-	-	-	-	-	4.0	-	15.0	-	-
294, 294A	-	-	-	-	-	10.0	-	-	-	-
295	-	-	-	-	-	3.0	-	12.5	-	-
296	-	-	-	-	-	11.0	-	-	-	-
306A, 332, 333, 336	.05	.15	.35	.5	.8	1.2	2.2	4.0	7.0	-
307A	-	-	-	-	-	7.5	-	-	-	-
360	-	.19	.40	.6	.9	1.5	2.8	6.0	9.0	-

AIAG 654

Table 10-3. Cross-Reference Between Coaxial Cables and Connectors. (Sheet 1 of 9)

CABLE TYPE RG-( )/U	CONNECTOR SERIES	APPLICABLE CONNECTORS UG-( )/U	NONCOMPATIBLE CONNECTORS UG-( )/U
5	C N	626,629,639,633 18,19,20,91,92,93,159	
5B	C N	NOTE	626,626A,630,633 18C,19C,20C,159B
6	C N	626,629,630,633 18,19,20,91,92,93,159	
6A	C N	626B,629A,630A,633A 18C,18D,19A,19B,19D,20B,20C 20D,91A,92A,93A,159A,159C	
8	BNC C HN N	959 570,571,572,573,710 59,60,61,427,1213,1214 21,22,23,160,594,1185,1186	
8A	C N	NOTE	942 21A,21B,21D,22A,22B,22D, 23A,23B,23D,160A,160B,160C
9	BNC C HN N	959 570,571,572,573,710 59,60,61,427 21,22,23,160,594,1185,1186	

AIAG 655

Table 10-3. Cross-Reference Between Coaxial Cables and Connectors. (Sheet 2 of 9)

CABLE TYPE RG-( )/U	CONNECTOR SERIES	APPLICABLE CONNECTORS UG-( )/U	NONCOMPATIBLE CONNECTORS UG-( )/U
9B	BNC C  HN  N  QDS End Seal	NOTE	959 570,571,572,573A,628A,632, 710A,937,938,939,942A, 943A,944,945A,1144 59,59C,59D,60,60C,60D,61 61C,61D,427A,427B,925, 925A,927,927A,929,929A, 930,930A,1213,1214,1215 21A,21B,21D,22A,22B,22D, 23A,23B,23D,160A,160B, 160C,1185,1186,1187 967,967A,968,972,972A,1132 MX-1554A
10	C HN N QDL QDS	937,938,939,942,943,944,945 925,927,929,930 935,936,940,941 1075,1076 967,968,1132	
11	BNC C HN N	959 570,571,572,573,710 59,60,61,427,1213,1214 21,22,23,94,95,96,160,594, 1185,1186	
11A	BNC C HN  N  QDS UHF End Seal End Seal End Seal	NOTE   MX-1461 MX-1465 MX-1554B	959A 570A,571A,572A,573B,710B 59E,60E,61B,61D,61E,427C, 1213,1214 21E,22E,23D,23E,94A,95A,96A, 160B,160D,594A,1185,1185A, 1186A 1278 266C,296,543
12	C HN N QDL QDS	937,938,939,942,943,944,945 925,927,929,930 935,936,940,941 1075,1076 967,968,1132	
12A	C  HN  N QDL QDS UHF End Seal	937A,938A,939A,942B,943A,943B 944,944A,945A,945B,1286 MX-564A,925B,927A,927B,929A, 929B,930B 106,935,935B,936B,940B,941B 1075C,1076C 967A,967B,968B,1132A 296 1461,1465	
13	BNC C HN N	959 570,571,572,573,710 59,60,61,427,1213,1214 21,22,23,160,594,1186	

AIAG 656

Table 10-3. Cross-Reference Between Coaxial Cables and Connectors. (Sheet 3 of 9)

CABLE TYPE RG-( )/U	CONNECTOR SERIES	APPLICABLE CONNECTORS UG-( )/U	NONCOMPATIBLE CONNECTORS UG-( )/U
13A	C HN N QDS End Seal	NOTE	570,571,572,573A,628A,632,710A, 937,938,939,942A,943A,944,945A 59,59C,59D,60,60C,60D,61,61C, 61D,427A,427B,925,925A,927, 927A,929,929A,930,930A,1213, 1214,1215 21A,21B,21D,22A,22B,22D,23A, 23B,23D,160A,160B,160C,1185, 1186,1187 967,967A,968,972,972A,1132 MX-1461,MX-1465A
14	C HN LN	707 494 100,101,279	
14A	C N QDS End Seal	NOTE	707A 204C,1006 1135 MX-1397A
17	C HN LC N	708 333,334,495 1179,1258 167	
17A	C End Seal	NOTE	708,708A MX-1490A
18	HN LC N QDL	1041,1102,1103 154 982,1195 1020,1073,1074	
19	LC	156	
19A	LC	NOTE	157,157A,219,219A
20	LC	156	
20A	LC	NOTE	157,157A,219,219A
21	C N	626,629,630,633 18,19,20,159	
22	UHF	102,103,106,421,422,423	
22B	UHF	102,103A,106,421B,422,423A	
25	PULSE	34,180,181,182	180A,181A,182A
26	PULSE	34,180,181,182	
27	PULSE	36,158,1141	
28	PULSE	166,174	
34	UHF	357,358	

AIAG 657

Table 10-3. Cross-Reference Between Coaxial Cables and Connectors. (Sheet 4 of 9)

CABLE TYPE RG-( )/U	CONNECTOR SERIES	APPLICABLE CONNECTORS UG-( )/U	NONCOMPATIBLE CONNECTORS UG-( )/U
35	HN LC N QDL	1041, 1041B, 1102, 1103 154, 154B 982, 1195 1020, 1020A, 1073, 1073B, 1074	
55	BN  BNC C N SM	85, 86, 87, 114, 115, 198, 206, 245, 246, 342 88, 89, 253, 291, 909, 913 704, 709 536, 556, 1052, 1095 699, 700, 923	
55A	BNC  C N End Seal	NOTE	88, 88A, 88B, 88C, 89, 89A, 89B, 253, 253A, 291, 291A, 291B, 909, 913 704, 709, 709A 536, 536A, 556, 556A MX-1684A, MX-1744A, MX-1884
58	BN  BNC C N SM	85, 85, 87, 114, 115, 198, 206, 245, 246, 342 88, 89, 253, 291, 909, 913 704, 709 536, 556, 1052, 1095 699, 700, 923	
58C	BN  BNC  C N  QDS SM UHF End Seal End Seal End Seal	85, 86, 87, 114, 115, 198, 206, 245, 246, 342 88C, 88D, 89B, 89C, MX-195A, 253B, 291C, 909, 909A, 913, 913A 704A, 709A, 709B 536, 536B, 556, 556B, 1052, 1095A, 1095B MX-1870, MX-1889 699, 700, 923 117, 203 MX-1684B MX-1744B MX-1884B	
59	BN BNC C N	85, 86, 87, 114, 115, 198, 206 260, 261, 291, 624, 909, 910, 913 704, 709 602, 603	
59B	BN BNC  C N QDS SM UHF End Seal End Seal End Seal End Seal	85, 86, 87, 114, 115, 198, 206 260B, 260C, 261B, 261C, 262C, 291C, MX-367, 624, 909, 909A, 910A, 913, 913A, MX-1758 704A, 709A, 709B 593, 602B, 603A, 603B MX-1870, MX-1889 692, 923 73, 111, 176, 203, 239, 266C, 366 MX-1530B MX-1531B MX-1801B MX-1802B	

AIAG 658

Table 10-3. Cross-Reference Between Coaxial Cables and Connectors. (Sheet 5 of 9)

CABLE TYPE RG-( )/U	CONNECTOR SERIES	APPLICABLE CONNECTORS UG-( )/U	NONCOMPATIBLE CONNECTORS UG-( )/U
62	BN BNC C N	85,86,87,114,115,198,206 260,261,262,624,910 627,631 593,602,603	
63	C HN N	570,571,572,573,710 59,60,61,427,1213,1214 21,22,23,160,594,1185,1186	
64	PULSE	180,181,182,264,1084	
65	PULSE	180,181,182,264,1084	
71	BN BNC C N SM	85,86,87,114,115,198,206 260,261,262,624,910 627,631 593,602,603 692,693	
74	HN N QDL QDS	1021 1006 1133 1134,1135	
74A	End Seal	NOTE	MX-1397A
77	PULSE	180,181,182,264	
78	PULSE	180,181,182,264	
79	C HN N QDS	937,938,939,942,943,944,945 925,927,929,930 935,936,940,941 967,968,1132	
81	HN N	312 483,486	
82	LC N	286,314 484,487	
85	LC	1179	
85A	LC End Seal End Seal End Seal	1179 MX-1169 MX-1170 MX-1901	
86	UHF	969	
87	BNC C HN N	959 570,571,572,710 59,60,61,427,1213,1214 160,1185,1186	
87A	BNC C	NOTE	959 570,571,572,573A,628A,632, 710A,937,938,939,942A,943A, 944,945A

AIAG 659

Table 10-3. Cross-Reference Between Coaxial Cables and Connectors. (Sheet 6 of 9)

CABLE TYPE RG-( )/U	CONNECTOR SERIES	APPLICABLE CONNECTORS UG-( )/U	NONCOMPATIBLE CONNECTORS UG-( )/U
87A	HN  N  QDS	NOTE	59,59C,59D,60,60C,60D,61,61C, 61D,427A,427B,925,925A,927, 927A,929,930A,1213,1214,1215 21A,21B,21D,22A,22B,22D,23A, 23B,23D,160A,160B,160C,594, 935,935A,936,936A,940,940A, 941,941A,1185,1186,1187 967,967A,968,972,972A,1132
88	PULSE	180,181,182,228,229,230	
88B	PULSE	NOTE	180A,181A,182A
94	HN LN	494 101,279	
100	BNC	527	
114	BNC C HN N	959 570,571,572,573,710 59,60,61,427,1213,1214 21,22,23,160,594,1185,1186	
115	C HN N	570,571,572,573,710 59,60,61,427,1213,1214 21,22,23,160,483,594, 1185,1186	
116	C HN  N QDS	937,938,939,942,943,944,945  935,936,940,941 967,968,1132	925,925A,927,927A,929,929A, 930,930A
117	C HN LT N	532	711,711A 926A  557
118	HN N	926	926A 557
119	LN	530,531	
122	BNC  C N	88,89,253,291,909,913,1033, 1055,1056,1082 704,709 536,556,1095	
126	C N	626,629,630,633 18,19,20,159	
130	UHF	1057,1060	
131	UHF	1057,1060	
133	BNC C HN	959 570,571,572,573,710 59,60,61,427,1213,1214	

AIAG 660



Table 10-3. Cross-Reference Between Coaxial Cables and Connectors. (Page 7 of 9)

CABLE TYPE RG-( )/U	CONNECTOR SERIES	APPLICABLE CONNECTORS UG-( )/U	NONCOMPATIBLE CONNECTORS UG-( )/U
133	N	21, 22, 23, 94, 95, 96, 160, 594, 1185 1186	
140	BNC C N	260, 261, 262, 624 627, 631 602, 603	
141	BNC C N	88, 89, 253, 291, 909, 913 704, 709 536, 556, 1052, 1095	
142	BNC C N	88, 89, 253, 291, 909, 913 704, 709 536, 556, 1095	
143	C N	626, 629, 630, 633 18, 19, 20, 159	
144	BNC C HN N	959 570, 571, 572, 573, 710 59, 60, 61, 427 21, 22, 23, 94, 95, 96, 160, 594, 1185, 1186	
149	BNC C HN N	959 570, 571, 572, 573, 710, 59, 60, 61, 427, 1213, 1214 21, 22, 23, 160, 594, 1185, 1186	
150	C HN N QDS	937, 938, 939, 942, 943, 944, 945 925, 927, 929, 930 935, 936, 940, 941 967, 968, 1132	
164	C HN  LC N	708, 708B 333, 333B, 333C, 334, 334B, 334C, 495, 495C, 495D, 1041, 1041B 1179, 1258 167, 167E	
165	BNC C HN N	959 570, 571, 572, 573, 710 59, 60, 61, 427, 1213, 1214 21, 22, 23, 160, 594, 1185, 1186	
166	C HN N QDS	937, 938, 939, 942, 943, 944, 945 925, 927, 929, 930 935, 936, 940, 941 967, 968, 1132	
177	C HN N LC	708 333, 334, 495 167 1179, 1258	
211	C LT	711B 532	
212	C N	626B, 629A, 30A, 633A 18D, 19D, 20D, 159C	

AIAG 661

Table 10-3. Cross-Reference Between Coaxial Cables and Connectors. (Sheet 8 of 9)

CABLE TYPE RG-( )/U	CONNECTOR SERIES	APPLICABLE CONNECTORS UG-( )/U	NONCOMPATIBLE CONNECTORS UG-( )/U
213	BNC C  HN N  QDS	959A 570A, 571A, 572A, 573B, 710B, 943A, 943B, 944, 944A, MX-1144 59E, 60E, 61E, 427C, 1213, 1214 21E, 22E, 23D, 23E, 160B, 160D, 594A, 936B, 940B, 941B, 1185A, 1186A 967A, 967B, 968B, 972A, 972B, 1075C, 1076C, 1132A, 1278, MX-1913	
214	BNC C  HN N  QDL QDS	959A 570, 571A, 572A, 573B, 710B, 937A, 943A, 943B, 944, 944A, MX-1142 59E, 60E, 61E, 427C, 1213, 1214 21E, 22E, 23D, 23E, 160B, 160D, 594A, 936B, 940B, 941B, 1185A, 1186A 1075C, 1076C 967A, 967B, 968B, 972A, 972B, 1132A, 1278, MX-1913	
215	C  HN N QDL QDS	937A, 938A, 939A, 940B, 941B, 942B, 943A, 943B, 944, 944A, 945A, 945B 925B, 927B, 929B, 930B 935B, 936B, 940B, 941B 1075C, 1076C, MX-1286 967A, 967B, 968A, 968B, 972A, 972B, 1132A	
216	BNC C HN N	959A 570A, 571A, 572A, 573B, 710B 59E, 60E, 61E, 427C, 1213, 1214 21E, 22E, 23E, 160D, 594A, 1185A, 1186A	
217	HN LN	494 101, 279	
218	C HN LC N QDL	708B 333, 334, 495 352, 1179, 1258 167E 946A, 1020A, 1073B, 1074A, 1074B	
219	HN LC N QDL	1041, 1102, 1103 154B, 352B 982, 1195, MX-1441 1020A, 1073, 1073B, 1074, 1074A, 1074B	
220	LC	156	
221	LC	156	
222	C N	626B, 629A, 630A, 633A 18D, 19D, 20D, 159C	
223	BNC C N	88D, 89C, 253B, 291C, 909A, 913A 704A, 709B 536B, 556A, 1095A	

AIAG 662

Table 10-3. Cross-Reference Between Coaxial Cables and Connectors. (Sheet 9 of 9)

CABLE TYPE RG-( )/U	CONNECTOR SERIES	APPLICABLE CONNECTORS UG-( )/U	NONCOMPATIBLE CONNECTORS UG-( )/U
224	HN LN QDS	1021 1079, 1080 1134, 1135	
225	BNC C HN N	959A 570A, 571A, 572A, 573B, 710B 59E, 60E, 61E, 427C, 1213, 1214 21E, 22E, 23E, 160D, 594A, 1185A, 1186A	
227	C  HN N QDS	937A, 938A, 939A, 942B, 943B, 944A, 945B 925B, 927B, 929B, 930B 935B, 936B, 940B, 941B 967B, 968A, 1132A	
228	HN	926	
NOTE: Refer to basic cable for applicable connectors, i.e., for RG-5B/U, see RG-5/U.			AIAG 663

Table 10-4. Bead Supported Coaxial Lines

Type	Over-all diameter Inches	Inner conductor	Supporting insulation		Bead diameter Inches	Minimum bend radius Inches	Weight lbs/100 ft	Nominal impedance ohms	Nominal capacitance pF/ft	Propagation constant at 100(MHz) percent	Average attenuation at 100(MHz) dB/ft	Maximum voltage rating at 100(MHz) volts	Recommended rating input at 100(MHz) watts	Maximum total power at 100(MHz) watts	Engr. data
			Spacing	Material											
	0.250	0.051-inch-diameter solid copper wire	2-1/2 turn per inch	Polyethylene	0.200	3	8.25	75	14.5	88.7	0.015	1,000	750	1,350	
	0.375	0.081-inch-diameter solid copper wire	2 inches	Stearite	0.311	8	15.75	72	14.5	86.2	0.011	2,900	1,500	3,000	
RG-162/U	3.065	0.156-inch-diameter copper tube		Polytetrafluoroethylene				175				30,000			
	0.875	0.250-inch-diameter copper tube	6 inches	Stearite	0.785		60.0	65	18.4	87.6	0.005	7,000	4,000	5,250	
	0.875	0.250-inch-diameter copper tube	3 inches	Stearite	0.785	5	60.0	65	18.4	87.6	0.005	7,000	4,000	5,250	
RG-92/U	0.875	0.375-inch-diameter copper tube		Polytetrafluoroethylene	0.812			46				4,000			
RG-80/U	0.9375	0.375-inch-diameter copper tube						51							
	1.625	0.625-inch-diameter copper tube	6 inches	Stearite	1.527		125.0	50	23.4	96.8	0.003	11,000	9,000	10,000	
N.T. 68200	1.625	0.638-inch-diameter copper tube	3 inches	Polytetrafluoroethylene	1.527		125.0	50	20.5	94.9	0.002	11,000	9,000	10,000	
	3.125	0.875-inch-diameter copper tube	12 inches	Stearite	3.027		230.0					21,500	25,000	25,500	
	3.125	0.875-inch-diameter copper tube	6 inches	Teflon	3.027		241.00					21,500	25,000	25,500	
CG-719/U	6.125	2.50-inch-diameter copper tube		Stearite	5.981			51.5	19.7						
CG-720/U	3.125	1.20-inch-diameter copper tube		Stearite	3.027		250.00	51.5	20.1						
RG-128/U	1.625	0.604-inch-diameter copper tube		Polytetrafluoroethylene interlocked				50		99.0	0.006	11,000			
RG-134/U	0.450	One, solid, copper 28AWG		Polytetrafluoroethylene				185	6.5			1,000			Flexible brass tubing

1/ With line at atmospheric pressure.  
 2/ Total input based on center-conductor temperature of 200° F., ambient 76° C.  
 3/ Thread, helically wrapped.

AIAG 664

Table 10-5. Physical Requirements, Coaxial Cable

TYPE	Line size	Outer conductor <sup>1/</sup>				Inner conductor <sup>1/</sup>			
		Diameter		Wall thickness		Diameter		Wall thickness <sup>2/</sup>	
		A	B	Nominal	Maximum deviation from average <sup>3/</sup>	C	D	Nominal	Maximum deviation from average <sup>3/</sup>
RG-152/U	6-1/8	6.125 ±.008	5.981 ±.008	0.072	0.012	2.600 ±.004	2.520 ±.004	0.040	0.0075
RG-154/U	3-1/8	3.125 ±.005	3.027 ±.005	0.049	0.0075	1.315 ±.003	1.231 ±.003	0.042	0.005
RG-153/U	1-5/8	1.625 ±.003	1.527 ±.003	0.049	0.005	0.6640 ±.0025	0.5880 ±.0025	0.038	0.005
RG-155/U	7/8	0.8750 ±.0025	0.7850 ±.0025	0.045	0.005	0.341 ±.002	0.291 ±.002	0.025	0.003
RG-151/U	3/8	0.375 ±.002	0.285 ±.002	0.045	0.0045	0.125 ±.002	---	Rod	---

<sup>1/</sup> All dimensions are in inches.

<sup>2/</sup> Average wall thickness is one-half the difference between the corresponding inside and outside diameters at any cross section perpendicular to the axis.

<sup>3/</sup> Maximum deviation of the wall thickness from the average wall thickness (eccentricity) at any cross section is the difference between the average wall thickness and either the maximum or minimum wall thickness, whichever is greater.

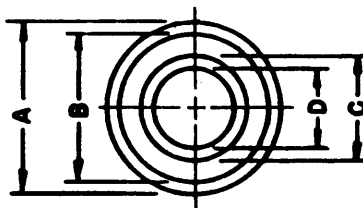

AIAG665

Table 10-6. Electrical Requirements, Coaxial Cable

TYPE	Frequency range, incl. (MHz)	Iterative impedance <sup>1</sup> / (ohms)			VSWR <sup>2</sup> / 	High potential test voltage (kv rms)	Transducer loss	
		Nominal	Max.	Min.			db/100 ft	Test frequencies (MHz)
RG-152/U	0.5 to 650	50	50.15	49.82	1.10:1	30.0	0.140	500
RG-154/U	0.5 to 1,300	50	50.26	49.73	1.10:1	15.0	0.330	800
RG-153/U	0.5 to 2,700	50	50.31	49.64	1.10:1	8.0	1.00	2,000
RG-155/U	0.5 to 3,300	50	50.57	49.48	1.10:1	4.0	2.20	2,000
RG-151/U	0.5 to 10,000	50	50.83	48.07	1.10:1	0.5	15.0	10,000

1. The iterative impedance for each line size, as shown, is exclusive of supports, and is for informational purposes.

2. VSWR tests shall be conducted on 20-foot lengths, minimum. AIAG666

Table 10-7. Stub-Supported Coaxial Lines

Type	Nominal impedance	Outer conductor		Inner conductor		Engineering data
		Outside diameter	Wall thickness	Outside diameter	Wall thickness	
	<u>ohms</u>	<u>inches</u>	<u>inch</u>	<u>inch</u>	<u>inch</u>	
RG-44/U	50	7/8	0.032	0.375	0.032	
RG-45/U	50	1-1/4	0.049	0.500	0.032	
RG-46/U	50	1-5/8	0.049	0.625	0.035	
RG-47/U	50	1/2	0.032	0.1875	0.032	
RG-76/U	50	5/8	0.032	0.250	0.022	
	50	5/16	0.025	0.125	0.032	
	50	3/8	0.090	0.125		
	70	7/8	0.042	0.250	0.032	
	70	7/8	0.032	0.250	0.022	
	70	7/8	0.045	0.2187	0.032	

AIAG 667

Table 10-8. Characteristics of Styroflex® Cables

RG-(1/U)	Overall Diameter (inches)	Impedance (ohms)	Inner Conductor (inches) I.D. O.D.	Outer Conductor (inches) I.D. O.D.	Jacket (inches) Wall O.D.	Weight (lb/1000 ft)	Minimum Bend Radius (inches)	Maximum Pulling Tension (lb)	Capacitance (pF/ft)	Inductance High Freq (uH/ft)	Velocity of Propagation (percent)	Dielectric Constant	Cutoff Frequency 90%-FCO (kHz)	60-Hertz Peak Test Voltage (kilovolts)	Maximum Peak Operating Voltage (kilovolts)
197	7/8	50	Solid 0.300	0.758 0.875	- 0.070	500	10.0	770	72	0.056	92	1.23	5.7	5.5	2.4
199	7/8	70	Solid 0.209	0.758 0.875	0.070 1.015	445	10.0	770	16	0.079	91	1.21	6.4	5.4	2.4
200	1-5/8	70	Solid 0.403	1.472 1.625	0.070 1.765	930	25.0	1850	16	0.079	90	1.23	3.2	10.5	4.6
232	7/8	50	Solid 0.300	0.758 0.875	0.070 1.015	580	10.0	770	22	0.056	90	1.23	5.7	5.5	2.4
233	1-5/8	50	Solid 0.481	1.472 1.625	0.070 1.765	1080	25.0	1850	22	0.056	91	1.21	3.0	10.8	4.7
234	3-1/8	50	Solid 1.157	2.850 3.125	0.070 3.265	3110	50.0	6450	22	0.055	92	1.17	1.5	19.0	8.7
236	1/2	50	Solid 0.161	0.421 0.500	- 0.050	165	5.0	270	24	0.058	87	1.31	10.1	3.1	1.3
240	1-5/8	50	Solid 0.481	1.472 1.625	- 0.050	200	5.0	270	24	0.058	87	1.31	10.1	3.1	1.3
242	3-1/8	50	Solid 1.157	2.850 3.125	- 0.050	930	25.0	1850	22	0.056	91	1.21	3.0	10.8	4.7
244	1/2	75	Solid 0.102	0.421 0.500	- 0.050	270	5.0	270	15	0.087	89	1.26	11.6	2.8	1.2
245	1/2	75	Solid 0.102	0.421 0.500	- 0.050	118	5.0	270	15	0.087	89	1.26	11.6	2.8	1.2
246	7/8	75	Solid 0.189	0.758 0.875	- 0.070	153	5.0	270	15	0.087	89	1.26	11.6	2.8	1.2
247	7/8	75	Solid 0.189	0.758 0.875	- 0.070	343	10.0	770	15	0.085	90	1.24	6.5	5.1	2.2
248	1-5/8	75	Solid 0.274	1.472 1.625	- 0.070	423	10.0	770	15	0.085	90	1.24	6.5	5.1	2.2
249	1-5/8	75	Solid 0.374	1.472 1.625	- 0.070	946	25.0	1850	15	0.084	91	1.20	3.4	10.0	4.3
250	3-1/8	75	Solid 0.632	2.850 3.125	- 0.070	1098	50.0	1850	15	0.084	91	1.20	2.4	10.0	4.3
251	3-1/8	75	Solid 0.632	2.850 3.125	- 0.070	2395	50.0	6450	15	0.083	92	1.18	1.7	19.0	8.5
-	3/8	50	Solid 0.112	0.296 0.375	- 0.030	97	4.0	210	24	0.059	86	1.35	14.3	2.2	0.96
-	3/4	50	Solid 0.251	0.632 0.750	- 0.050	112	4.0	210	24	0.059	86	1.35	14.3	2.2	0.96
-	3/4	50	Solid 0.251	0.632 0.750	- 0.050	380	7.5	620	23	0.056	90	1.24	6.9	4.6	2.0
-	1-1/8	50	Solid 0.298	1.007 1.125	- 0.070	430	7.5	620	23	0.056	90	1.24	6.9	4.6	2.0
-	1-1/8	50	Solid 0.400	1.007 1.125	- 0.070	540	17.0	1040	22	0.056	90	1.23	4.3	7.4	3.2
-	1-1/8	50	Solid 0.497	1.472 1.625	- 0.070	650	17.0	1040	22	0.056	90	1.23	4.3	7.4	3.2
-	4-1/8	50	Solid 1.340	3.730 4.125	- 0.115	4750	60.0	10,000	22	0.055	92	1.18	1.2	27.0	11.8
-	6-1/8	50	Solid 2.250	5.512 6.125	- 0.115	5500	60.0	10,000	22	0.055	92	1.18	1.2	27.0	11.8
-	1/2	70	Solid 0.114	0.421 0.500	- 0.050	11,300	90.0	28,000	22	0.054	93	1.15	0.8	40.0	17.5
-	1/2	70	Solid 0.114	0.421 0.500	- 0.050	125	5.0	270	16	0.078	89	1.25	11.3	3.0	1.3
-	3/4	70	Solid 0.173	0.632 0.750	- 0.050	280	5.0	270	16	0.078	89	1.25	11.3	3.0	1.3
-	3/4	70	Solid 0.173	0.632 0.750	- 0.050	330	7.5	620	16	0.079	90	1.23	7.6	4.4	1.9
-	7/8	70	Solid 0.209	0.758 0.875	- 0.070	365	7.5	620	16	0.079	90	1.23	7.6	4.4	1.9
-	1-1/8	70	Solid 0.276	1.007 1.125	- 0.070	490	10.0	770	16	0.079	91	1.21	6.4	5.4	2.4
-	1-1/8	70	Solid 0.276	1.007 1.125	- 0.070	600	17.0	1040	16	0.079	91	1.21	6.4	5.4	2.4
-	1-5/8	70	Solid 0.403	1.472 1.625	- 0.070	780	17.0	1040	16	0.079	90	1.23	4.8	7.1	3.1
-	3-1/8	70	Solid 0.658	2.850 3.125	- 0.070	2520	25.0	1850	16	0.079	90	1.23	3.2	10.5	4.6
-	3-1/8	70	Solid 0.658	2.850 3.125	- 0.070	2930	50.0	6450	16	0.078	92	1.19	1.7	19.0	8.7
-	7/8	100	Solid 0.114	0.758 0.875	- 0.070	286	10.0	770	12	0.078	92	1.19	1.7	19.0	8.7
-	7/8	100	Solid 0.114	0.758 0.875	- 0.070	366	10.0	770	12	0.116	88	1.30	6.9	4.3	1.9
-	1-5/8	100	Solid 0.231	1.472 1.625	- 0.070	820	25.0	1850	11	0.113	90	1.30	6.9	4.3	1.9
-	1-5/8	100	Solid 0.231	1.472 1.625	- 0.070	970	25.0	1850	11	0.113	90	1.23	3.6	8.5	3.7
-	3-1/8	100	Solid 0.368	2.850 3.125	- 0.070	2100	50.0	6450	11	0.110	92	1.17	1.9	17.0	7.4
-	3-1/8	100	Solid 0.368	2.850 3.125	- 0.070	2510	50.0	6450	11	0.110	92	1.17	1.9	17.0	7.4

NOTE: Attenuation ratings and power handling capabilities at various frequencies are given in table 10-9.

AT&T 668

Table 10-9. Attenuation and Power Ratings of Styroflex® Cables

Attenuation At Various Frequencies (MHz) Decibels Per 100 Feet			Power Ratings (KW) At Various Frequencies (MHz)																				
RG-( )/U	SIZE	IMPEDANCE (ohms)	10	50	100	300	500	700	1000	3000	5000	10000	10	50	100	300	500	700	1000	3000	5000	10000	
197,232	7/8	50	0.14	0.30	0.44	0.79	1.10	1.30	1.60	3.10	4.40	-	18.0	8.0	5.6	3.2	2.4	2.0	1.6	0.84	0.61	-	-
199	7/8	70	0.13	0.28	0.40	0.72	0.95	1.20	1.40	2.90	4.00	-	15.5	7.1	5.0	2.8	2.2	1.8	1.4	0.75	0.54	-	-
200	1-5/8	70	0.069	0.15	0.22	0.40	0.55	0.68	0.85	1.80	-	-	41.0	18.0	12.8	7.0	5.2	4.2	3.3	1.6	-	-	-
233,240	1-5/8	50	0.072	0.16	0.23	0.42	0.58	0.70	0.89	1.90	-	-	48.0	21.0	14.6	8.2	6.2	5.1	4.1	1.9	-	-	-
234,242	3-1/8	50	0.037	0.084	0.12	0.24	0.32	0.41	0.52	-	-	-	1.25	54.0	37.0	20.0	14.8	12.0	9.5	-	-	-	-
236,237	1/2	50	0.25	0.56	0.80	1.40	1.90	2.30	2.80	5.20	7.10	11.20	7.7	3.40	2.4	1.4	1.0	0.87	0.72	0.38	0.28	0.18	0.18
244,245	1/2	75	0.23	0.52	0.74	1.30	1.70	2.10	2.50	4.80	6.50	10.50	6.9	3.2	2.2	1.3	1.0	0.82	0.68	0.37	0.27	0.18	0.18
246,247	7/8	75	0.13	0.29	0.42	0.75	1.00	1.20	1.50	2.90	4.10	-	13.9	6.1	4.3	2.4	1.8	1.5	1.2	0.64	0.46	-	-
248,249	1-5/8	75	0.069	0.15	0.22	0.41	0.56	0.69	0.85	1.80	-	-	37.5	16.5	11.5	6.4	4.7	3.8	3.1	1.5	-	-	-
250,251	3-1/8	75	0.035	0.081	0.12	0.24	0.32	0.41	0.52	-	-	-	100.0	43.0	29.5	15.9	11.5	9.3	7.4	-	-	-	-
-	3/8	50	0.24	0.80	1.15	2.00	2.60	3.20	3.90	7.20	9.80	15.10	4.3	1.9	1.3	0.76	0.58	0.48	0.40	0.24	0.16	0.11	0.11
-	3/4	50	0.16	0.36	0.52	0.92	1.20	1.50	1.80	3.60	5.0	-	13.5	6.2	4.3	2.4	1.9	1.5	1.3	0.65	0.46	-	-
-	1-1/8	50	0.11	0.23	0.34	0.62	0.83	1.00	1.20	2.60	-	-	26.0	11.8	8.2	4.6	3.5	2.9	2.3	1.2	-	-	-
-	4-1/8	50	0.029	0.066	0.099	0.19	0.26	0.33	0.42	-	-	-	175.0	74.0	51.0	27.0	20.0	16.0	12.7	-	-	-	-
-	6-1/8	50	0.020	0.046	0.069	0.15	0.19	0.24	-	-	-	-	300.0	134.0	85.0	46.0	34.0	27.0	-	-	-	-	-
-	1/2	70	0.23	0.52	0.74	1.30	1.70	2.10	2.50	4.80	6.50	10.50	6.9	3.2	2.2	1.3	1.0	0.82	0.68	0.37	0.27	0.18	0.18
-	3/4	70	0.15	0.34	0.49	0.88	1.20	1.40	1.70	3.40	4.80	-	12.0	5.4	3.9	2.2	1.7	1.4	1.1	0.58	0.41	-	-
-	1-1/8	70	0.10	0.22	0.32	0.58	0.76	0.94	1.10	2.30	-	-	23.0	10.4	7.3	4.1	3.1	2.5	2.0	1.0	-	-	-
-	3-1/8	70	0.036	0.081	0.12	0.23	0.32	0.39	0.50	-	-	-	109.0	48.0	33.0	17.5	13.0	10.2	8.3	-	-	-	-
-	7/8	100	0.14	0.32	0.47	0.85	1.10	1.40	1.70	3.20	4.40	-	9.6	4.3	3.0	1.7	1.3	1.1	0.86	0.46	0.33	-	-
-	1-5/8	100	0.072	0.16	0.24	0.43	0.58	0.71	0.89	1.7	-	-	29.0	12.5	8.7	4.9	3.7	3.1	2.5	1.3	-	-	-
-	3-1/8	100	0.034	0.08	0.12	0.24	0.30	0.38	0.47	-	-	-	81.0	34.1	23.5	13.0	9.5	7.8	6.3	-	-	-	-

AIAG 669



Table 10-10. Characteristics of Spir-O-Lines® Cables

RG-( )/U	NOMINAL SIZE (inches)	EFFECTIVE DIELECTRIC CONSTANT	VELOCITY (percent)	60- HERTZ PEAK TEST VOLTAGE (k-v)	OUTER CONDUCTOR (inches)		INNER CONDUCTOR (inches)		JACKET WALL (inches)	MINIMUM BEND RADIUS (inches)	MAXIMUM PULLING TENSION (pounds)	NET WEIGHT (lb/1000 ft)	IMPEDANCE (ohms)
					O.D.	I.D.	O.D.	I.D.					
252	1/2	1.44	85.5	3.4	0.530	0.456	0.165	Solid	-	5	270	175	50
253	1/2	1.44	85.5	3.4	0.530	0.456	0.165	Solid	0.05	5	270	225	50
254	7/8	1.44	85.5	6.0	0.953	0.833	0.311	Solid	0.07	10	770	655	50
255	7/8	1.44	85.5	6.0	0.953	0.833	0.311	Solid	-	10	770	555	50
257	1-5/8	1.44	85.5	11.0	1.786	1.622	0.606	0.06	-	25	1850	1200	50
258	1-5/8	1.44	85.5	11.0	1.786	1.622	0.606	0.06	0.07	25	1850	1380	50
259	3/8	1.44	85.5	2.2	0.390	0.316	0.115	Solid	-	4	210	100	50
260	3/8	1.44	85.5	2.2	0.390	0.316	0.115	Solid	0.03	4	210	140	50
261	3-1/8	1.44	85.5	19.0	3.370	3.09	1.219	0.08	-	60	6500	2900	50
262	3-1/8	1.44	85.5	19.0	3.370	3.09	1.219	0.08	0.07	60	6500	3300	50
-	3/8	1.44	85.5	2.2	0.390	0.316	0.071	Solid	-	4	210	100	75
-	3/8	1.44	85.5	2.2	0.390	0.316	0.071	Solid	0.03	4	210	140	75
-	1/2	1.44	85.5	3.4	0.530	0.456	0.104	Solid	-	5	270	175	75
-	1/2	1.44	85.5	3.4	0.530	0.456	0.104	Solid	0.05	5	270	225	75
-	7/8	1.44	85.5	6.0	0.953	0.833	0.191	Solid	-	10	770	555	75
-	7/8	1.44	85.5	6.0	0.953	0.833	0.191	Solid	0.07	10	770	655	75
-	1-5/8	1.44	85.5	11.0	0.953	1.622	0.372	0.06	-	25	1850	1200	75
-	1-5/8	1.44	85.5	11.0	0.953	1.622	0.372	0.06	0.07	25	1850	1380	75
-	3/8	1.44	85	2.2	0.390	0.316	0.115	Solid	-	4	210	100	50
-	1/2	1.44	85	3.4	0.530	0.456	0.165	0.020	-	5	270	175	50
RG-256	7/8	1.44	85	6.0	0.953	0.833	0.311	0.028	-	10	770	550	50
-	1-5/8	1.44	85	11.0	1.786	1.622	0.606	0.060	-	25	1850	1200	50

\* D signed to operate at ambient temperatures of 180°C (356°F).

AIAG 670

Table 10-11. Attenuation of Spir-O-Line<sup>®</sup> Cables

RG-( )/U	NOMINAL SIZE (inches)	IMPEDANCE (ohms)	Frequency (MHz)									
			1	10	30	100	200	300	400	1000	3000	10000
252	1/2	50	0.072	0.23	0.40	0.75	1.08	1.32	1.54	2.43	4.7	11.8
253	1/2	50	0.072	0.23	0.40	0.75	1.08	1.32	1.54	2.34	4.7	11.8
254	7/8	50	0.042	0.13	0.23	0.42	0.61	0.75	0.87	1.4	2.75	---
255	7/8	50	0.042	0.13	0.23	0.42	0.61	0.75	0.87	1.4	2.75	---
257	1-5/8	50	0.022	0.069	0.12	0.23	0.32	0.40	0.46	0.77	1.75	---
258	1-5/8	50	0.022	0.069	0.12	0.23	0.32	0.40	0.46	0.77	1.75	---
259	3/8	50	0.108	0.33	0.59	1.14	1.65	2.05	2.40	3.9	7.3	14.8
260	3/8	50	0.108	0.33	0.59	1.14	1.65	2.05	2.40	3.9	7.3	14.8
261	3-1/8	50	0.011	0.030	0.056	0.11	0.17	0.21	0.25	0.45	---	---
262	3-1/8	50	0.011	0.030	0.056	0.11	0.17	0.21	0.25	0.45	---	---
---	1/2	75	0.072	0.230	0.40	0.75	1.08	1.34	1.55	2.50	4.60	10.0
---	7/8	75	0.040	0.130	0.23	0.44	0.65	0.80	0.93	1.53	2.80	---
---	1-5/8	75	0.021	0.068	0.12	0.24	0.35	0.42	0.51	0.83	1.75	---
	HI-TEMP											
---	3/8	50	0.108	0.33	0.59	1.14	1.65	2.05	2.40	3.9	7.3	14.8
---	1/2	50	0.072	0.23	0.40	0.75	1.08	1.32	1.54	2.43	4.7	11.8
256	7/8	50	0.042	0.13	0.23	0.42	0.61	0.75	0.87	1.4	2.75	---
---	1-5/8	50	0.022	0.069	0.12	0.23	0.32	0.40	0.46	0.77	1.75	---

AIAG 671

Table 10-12. Average Power Rating of Spir-O-Line<sup>®</sup> Coaxial Cables (kW) (VSWR 1.1:1.0)

RG-( )/U	NOMINAL SIZE (inches)	IMPEDANCE (ohms)	Frequency (MHz)								
			10	30	100	200	300	400	1000	3000	10000
252	1/2	50	7.7	4.5	2.45	1.74	1.42	1.20	0.73	0.39	0.18
253	1/2	50	7.7	4.5	2.45	1.74	1.42	1.20	0.73	0.39	0.18
254	7/8	50	18.0	10.5	5.60	3.95	3.20	2.70	1.65	0.87	---
255	7/8	50	18.0	10.5	5.60	3.95	3.20	2.70	1.65	0.87	---
257	1-5/8	50	48.0	27.0	14.30	9.80	8.00	6.80	4.00	2.00	---
258	1-5/8	50	48.0	27.0	14.30	9.80	8.00	6.80	4.00	2.00	---
259	3/8	50	4.2	2.48	1.39	0.97	0.78	0.67	0.40	0.22	0.11
260	3/8	50	4.2	2.48	1.39	0.97	0.78	0.67	0.40	0.22	0.11
261	3-1/8	50	100.0+	65.0	33.0	22.50	18.0	15.4	8.8	---	---
262	3-1/8	50	100.0+	65.0	33.0	22.50	18.0	15.4	8.8	---	---
---	1/2	75	5.9	2.9	1.84	1.29	1.05	0.90	0.56	0.30	0.15
---	7/8	75	14.0	7.8	4.20	2.95	2.40	2.05	1.25	0.65	---
---	1-5/8	75	37.0	21.5	11.80	8.30	6.60	5.70	3.30	1.58	---
	HI-TEMP										
---	3/8	50	4.2	2.48	1.39	0.97	0.78	0.67	0.40	0.22	0.11
---	1/2	50	7.7	4.5	2.45	1.74	1.42	1.20	0.73	0.39	0.18
256	7/8	50	18.0	10.5	5.6	3.95	3.20	2.70	1.65	0.87	---
---	1-5/8	50	48.0	27.0	14.3	9.80	8.00	6.80	4.00	2.00	---

AIAG 672

Table 10-13. Characteristics of Heliax® Cable

RG-(-) /U	NOMINAL SIZE (INCHES)	NOMINAL IMPEDANCE (OHMS)	ATTENUATION (1000 MHz)	AVERAGE POWER (KW) (1000 MHz)	TYPE OF INSULATION	VELOCITY	FREQUENCY CUTOFF (MHz)	DIAMETER OUTER COND. (INCHES)	DIAMETER INNER COND. (INCHES)	WEIGHT LBS/1000 FT	BEND RADIUS (MIN) (IN.)
266	1-2	50	2.6	0.52	Air-Poly	91.4	12100	.500	.164	200	5
269A	7/8	50	1.35	1.24	Air-Poly	91.6	5800	1.005	.358	430	10
270B	1-5/8	50	0.7	4.4	Air-Poly	92.1	2920	1.830	.600	875	20
284	7/8	100	1.35	2.1	Air-Poly	90.0	6200	1.005	.229	450	10
285A	7/8	75	1.6	1.0	Air-Teflon	92.5	7300	1.005	.114	360	10
286	1-5/8	100	0.72	2.8	Air-Poly	92.4	3300	1.830	.430	750	20
287	1-5/8	75	0.7	2.0	Air-Poly	92.1	3300	1.830	.430	750	20
292*	1-5/8	50	0.72	2.8	Air-Poly	92.4	3300	1.830	.430	750	20
297	7/8	75	1.6	2.1	Air-Teflon	92.5	5800	1.005	.358	430	10
305*	1-5/8	50	1.12	3.4	Air-Poly	93.3	3300	1.830	.430	750	20
318*	7/8	50	1.35	1.24	Air-Poly	91.6	5800	1.005	.358	430	10
319*	1-5/8	50	0.7	4.4	Air-Poly	92.1	2920	1.830	.713	720	20
321	3	50	0.5	9.6	Air-Poly	93.3	1820	2.850	1.140	1200	36
322*	3	50	0.5	9.6	Air-Poly	93.3	1820	2.850	1.140	1200	36
323*	7/8	50	2.0	1.05	Foam-Poly	79.0	4900	.980	.3125	360	10
324	7/8	50	2.0	1.05	Foam-Poly	79.0	4900	.980	.3125	360	10
366*	1/2	50	3.6	0.58	Foam-Poly	79.0	9000	.540	.171	190	5
367*	5	50	0.28	20.5	Air-Poly	93.0	1050	5.00	2.02	3020	60

\*Has a protective polyethylene outer jacket.

AIAG 673

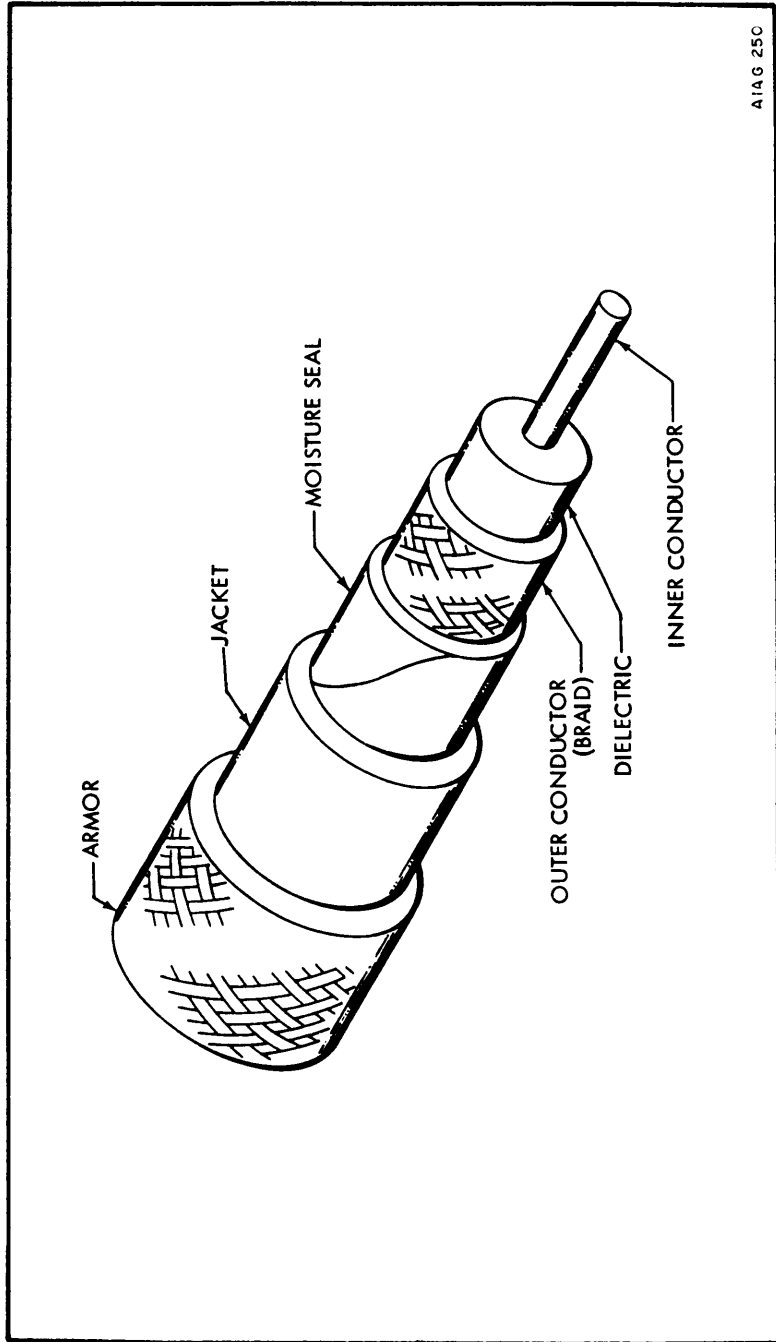
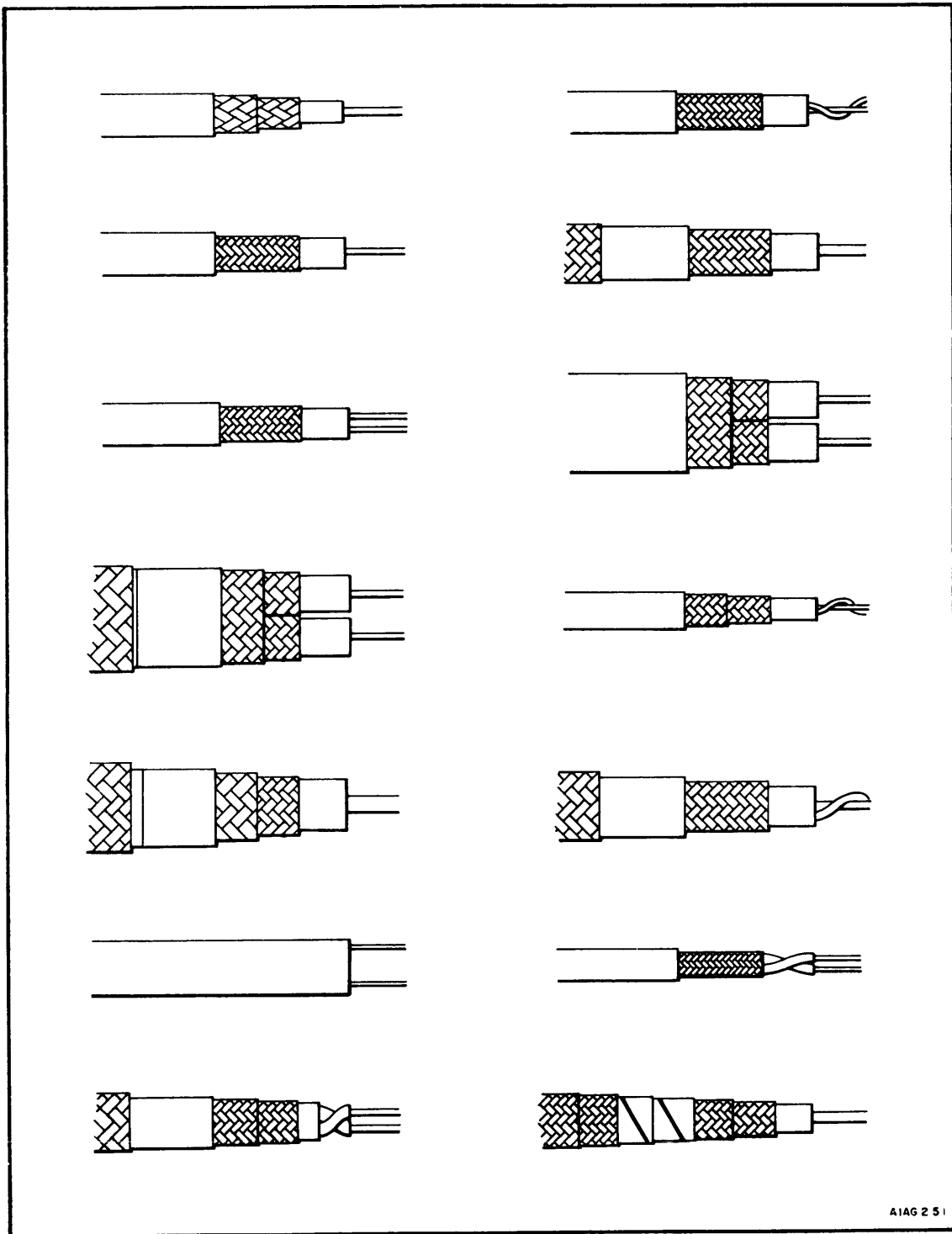

Figure 10-1. Typical Coaxial Cable



A1AG 2 51

Figure 10-2. Coaxial Cable Configurations  
(Sheet 1 of 2)

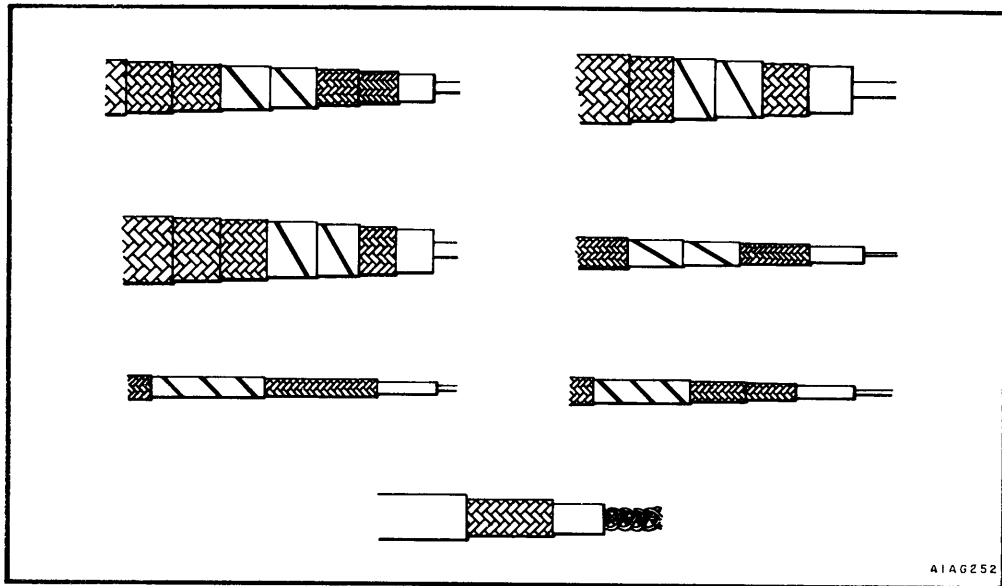

Figure 10-2. Coaxial Cable Configurations  
(Sheet 2 of 2)

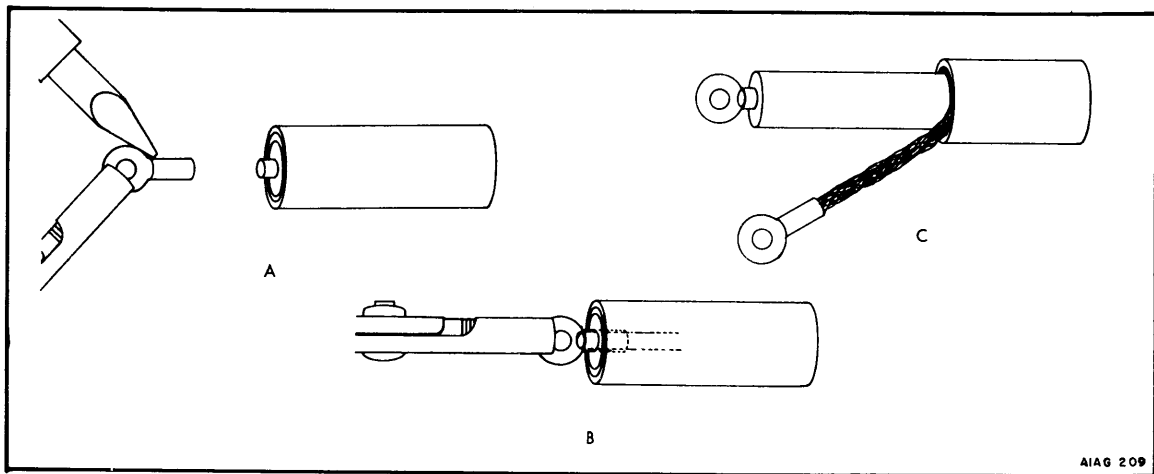
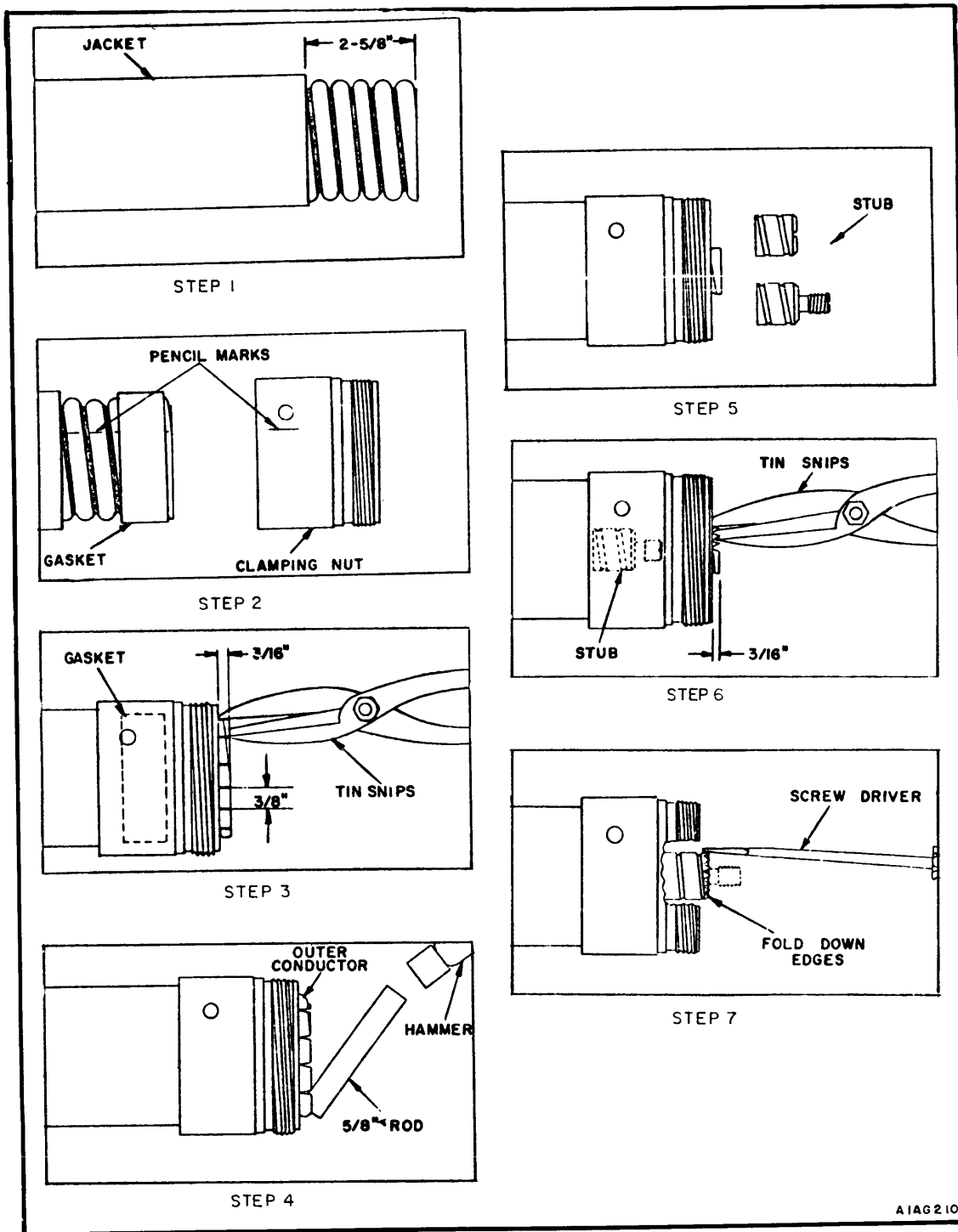

Figure 10-3. Connecting Cable to a Solder Terminal



AIAG 210

Figure 10-4. Connecting Cable to Flange  
(Sheet 1 of 2)

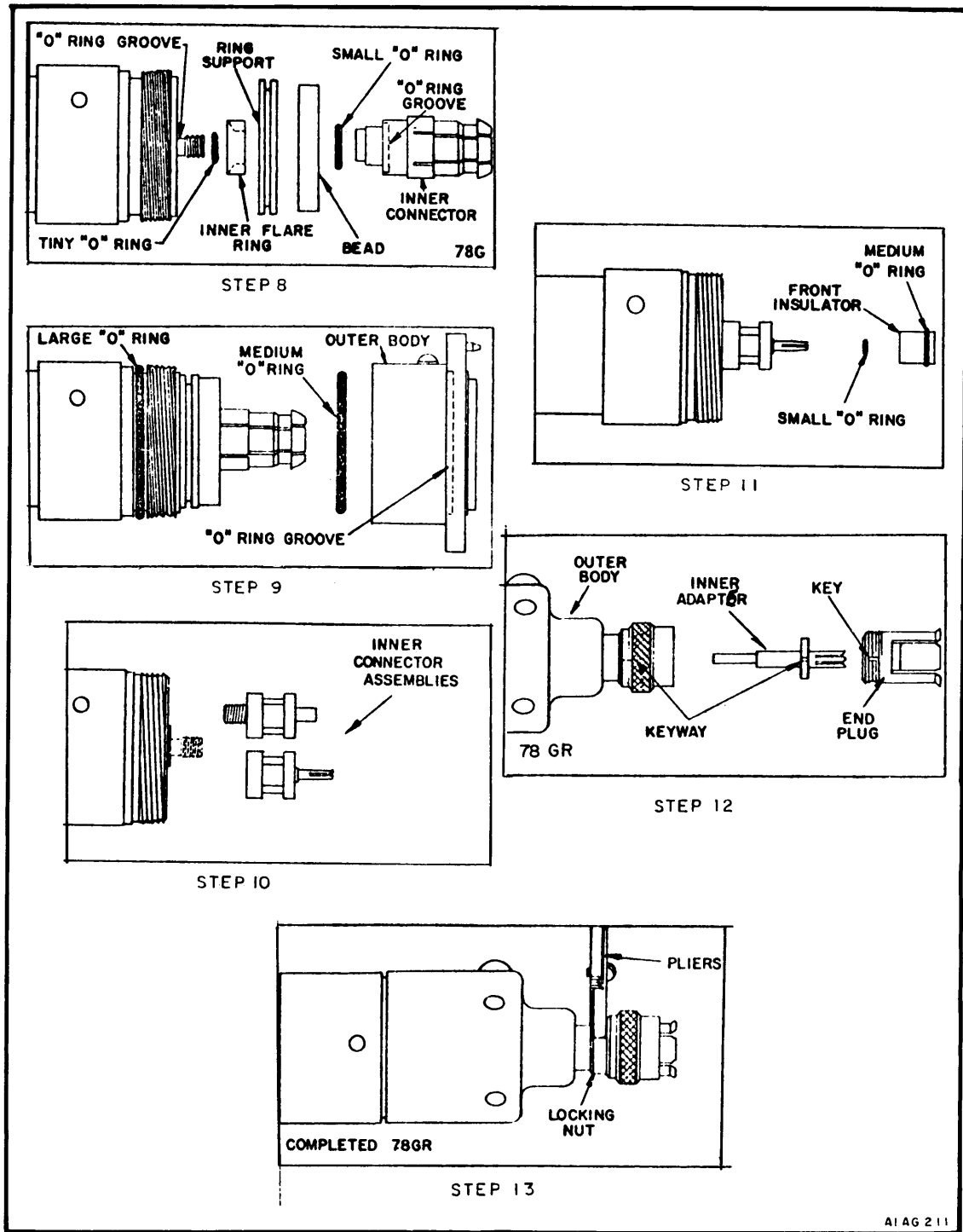

Figure 10-4. Connecting Cable to Flange  
(Sheet 2 of 2)